

KAUNAS UNIVERSITY OF TECHNOLOGY
LITHUANIAN ENERGY INSTITUTE

MARIUS PRASPALIAUSKAS

**INVESTIGATION OF SEWAGE SLUDGE PYROLYSIS PRODUCTS
AND RESIDUAL SOLID MATERIAL INFLUENCE TO FIBRE HEMP
BIOMASS PRODUCTION**

Summary of Doctoral Dissertation

Technological Sciences, Energetics and Power Engineering (T 006)

2019, Kaunas

Dissertation was prepared during the period 2014–2018 at Lithuanian Energy Institute, Laboratory of heat equipment research and testing.

Scientific Supervisor:

Assoc. Prof. Dr. Nerijus STRIŪGAS (Lithuanian Energy Institute, Technological Sciences, Energetics and Power Engineering – T 006).

Editor: Jūratė Kulčickytė-Gutaitė

Dissertation Defence Board of Energetics and Power Engineering Science Field:

Prof. Dr. Habil. Gintautas MILIAUSKAS (Kaunas University of Technology, Technological Science, Energetic and Power Engineering – T 006) - **Chairman**,

Prof. Dr. Habil. Dagnija BLUMBERGA (Riga Technical University, Latvia, Technological Science, Energetic and Power Engineering – T 006),

Prof. Dr. Algirdas JASINSKAS (Vytautas Magnus University Agriculture Academy, Technological Science, Environmental Engineering, T 004),

Dr. Jūratė KRIAUCIŪNIENĖ, (Lithuanian Energy Institute, Technological Science, Environmental Engineering, T 004),

Dr. Raimondas PABARČIUS (Lithuanian Energy Institute, Technological Science, Energetic and Power Engineering, T 006).

The official defence of the dissertation will be held at 2 p.m. on 7 May, 2019 at the public meeting of Dissertation Defence Board of Energetics and Power Engineering Science Field in Meeting Hall at Lithuanian Energy Institute.

Address: Breslaujos g. 3-202, 44403 Kaunas, Lithuania.

Tel. no. (+370) 37 300 042; fax. (+370) 37 324 144; e-mail doktorantura@ktu.lt.

Summary of doctoral dissertation was sent on 7 April, 2019.

The doctoral dissertation is available on the internet <http://ktu.edu> and at the libraries of Kaunas University of Technology (K. Donelaičio St. 20, 44239 Kaunas, Lithuania) and Lithuanian Energy Institute (Breslaujos g. 3, 44403 Kaunas, Lithuania).

KAUNO TECHNOLOGIJOS UNIVERSITETAS
LIETUVOS ENERGETIKOS INSTITUTAS

MARIUS PRASPALIAUSKAS

**NUOTEKŲ DUMBLO PIROLIZĖS PROCESO PRODUKTŲ IR
SUSIDARIUSIOS KIETOSIOS FRAKCIJOS ĮTAKOS
PLUOŠTINĖS KANAPĖS BIOMASĖS PRIEAUGIUI TYRIMAS**

Daktaro disertacijos santrauka

Technologijos mokslai, energetika ir termoinžinerija (T 006)

2019, Kaunas

Disertacija rengta 2014–2018 m. Lietuvos energetikos institute, Šiluminių įrengimų tyrimo ir bandymų laboratorija.

Mokslinis vadovas:

Doc. dr. Nerijus STRIŪGAS (Lietuvos energetikos institutas, technologijos mokslai, energetika ir termoinžinerija – T 006).

Redagavo: Jūratė Kulčickytė-Gutaitė

Energetikos ir termoinžinerijos mokslo krypties disertacijos gynimo taryba:

Prof. habil. dr. Gintautas MILIAUSKAS (Kauno technologijos universitetas, Technologijos mokslai, Energetika ir termoinžinerija, T 006) pirmininkas,

Prof. habil. dr. Dagnija BLUMBERGA (Rygos technikos universitetas, Latvija, Technologijos mokslai, Energetika ir termoinžinerija, T 006),

Prof. habil. dr. Algirdas JASINSKAS (Vytauto Didžiojo universiteto Žemės ūkio akademija, Technologijos mokslai, Aplinkos inžinerija T 004),

Dr. Jūratė KRIAUCIŪNIENĖ (Lietuvos energetikos institutas, Technologijos mokslai, Aplinkos inžinerija T 004),

Dr. Raimondas PABARČIUS (Lietuvos energetikos institutas, Technologijos mokslai, Energetika ir termoinžinerija, T 006).

Disertacija bus ginama viešame energetikos ir termoinžinerijos mokslo krypties disertacijos gynimo tarybos posėdyje 2019 m. gegužės 7 d. 14 val. Lietuvos energetikos instituto posėdžių salėje.

Adresas: Breslaujos g. 3–202, 44403 Kaunas, Lietuva.

Tel. (370) 37 300 042; faks. (370) 37 324 144; el. paštas doktorantura@ktu.lt.

Disertacijos santrauka išsiųsta 2019 m. balandžio 7 d.

Su disertacija galima susipažinti internetinėje svetainėje <http://ktu.edu>, Kauno technologijos universiteto (K. Donelaičio g. 20, 44239 Kaunas) ir Lietuvos energetikos institute (Breslaujos g. 3, 44403 Kaunas).

THE CONTENT OF THE SUMMARY OF DOCTORAL DISSERTATION

INTRODUCTION.....	6
1. LITERATURE REVIEW.....	11
2. EXPERIMENTAL SETUP AND METHODOLOGY.....	13
2.1 ..Investigation of pyrolysis process	14
2.1.1 The methodology for experimental investigation of sewage sludge during pyrolysis.....	14
2.1.2 Material characterization and elemental analysis	15
2.2 Sewage sludge and sewage sludge char to fibre hemp (<i>Cannabis sativa</i> <i>L.</i>) biomass production.....	16
3. RESULTS AND DISCUSSION	17
3.1 Results of pyrolysis process investigation	17
3.1.1 Chemical composition of the sewage sludge, char, tar and condensate	17
3.1.2 Elemental distribution in pyrolysis products	18
3.1.3 Relative enrichment of heavy metals and elemental recoveries....	21
3.2 Results of fibre hemp fertilisation of sewage sludge and sludge char	25
3.2.1 Biometric parameters of fibre hemp	25
3.2.2 Accumulation factor to fibre hemp parts	27
3.3 Practical possibilities of using the results obtained	32
CONCLUSIONS.....	35
PUBLICATIONS RELATED TO THE DISSERTATION	37
REZIUMÉ	40

INTRODUCTION

Population growth, especially in urban areas, results in the increasing quantity of domestic sewage that concentrates in one place. For this reason, sewage treatment produces more sewage sludge. Recently, this problem is becoming increasingly important and is called “waste related future problem”. Efficient use of sewage sludge is a priority in handling sewage sludge produced. EU Member States should promote the recycling of products according to the following principle: “Reduce, Reuse, Recycle” to create a recycling society and, if only possible, to encourage the recycling of waste instead of its landfilling or burning. According to European Union environmental regulations, waste management methods related to storage are currently being changed to methods that regulate the safe recycling, reuse of such waste and development of new products. This also promotes the sustainable use of sewage sludge to produce valuable products that continue to be useful in agriculture, in production of various products, heat and energy generation. There are many methods of direct use of sewage sludge, including storage of sludge in storage sites (as raw fuel) or direct use as fertilisers in agriculture. Direct uses of sewage sludge in many countries are either banned or strictly regulated due to increased concentrations of heavy metals. For this reason, economic, environmental and social challenges are encountered when it comes to further use of sewage sludge. However, using sewage sludge in several areas and producing useful products reduces the environmental impact and economic costs of waste management, and negative judgments from society also decreases.

An overview of research results shows that there are many and varied ways of treating and using sewage sludge. However, due to high concentrations of heavy metals, the development of such technologies is not widely elaborated. Pyrolysis is an alternative to the aforementioned sewage sludge treatment processes. However, there is not enough information on the distribution of heavy metals, little research was done on the distribution of alkaline-earth metals and alkaline metals and non-metals in pyrolysis products. Research results show that the substances / products produced by pyrolysis are beneficial and that there will be more perspectives in the future for the development of their use. It is necessary to know the distribution of heavy metals and other elements in sewage sludge pyrolysis products when applying different heat treatment temperatures. When the distribution of the elements of the pyrolysis products obtained in different temperature regimes is known, the products can be further used in other areas. The use of solid fraction (sludge pyrolysis carbon), which remains after heat treatment, for the increase of biomass growth of energy crops, depending on concentration of heavy metals, is one of examples of possible uses. Analysis of literature revealed that pyrolysis processes are studied within the range 250-800°C. It is known that higher temperature of pyrolysis process results in more gaseous and

liquid products, and residual carbon is minimized. For this reason, a high pyrolysis temperature should be maintained in order to minimize quantity of sewage sludge to the maximum extent possible. Earlier research by Lithuanian Energy Institute showed that the optimum disposal temperature for waste, including sewage sludge, is 850°C. At this temperature, waste volumes are minimized to the maximum extent possible and problems of formation of agglomerates are avoided, as well secondary products are produced.

Sewage sludge pyrolysis carbon, which can be used for soil fertilization or regeneration if the technology used makes it possible to produce a product that is suitable for the use (e.g. biomass for energy crops), is the predominant element after the pyrolysis process. Although the effect of plant fertilization with sewage sludge and sewage sludge carbon is quite widely studied, there is not enough information on the amounts of heavy metals, alkaline earth metals and alkaline metals absorbed by energy crops which are increasingly used. These are the plants that increase soil efficiency and their ground biomass can be used in the energy sector. Hemp (*Cannabis sativa L.*) is one of the examples of such plants. The increasing use of hemp in the energy sector is a relatively new area and there is not enough information about the potential quantities of biomass yield when sewage sludge or sewage sludge carbon is used. Neither there is enough information on the distribution of heavy metals in separate parts of hemp (roots, stem, leaves) at different fertilization intensities. All this is important to evaluate because increased element concentrations cause problems with ash melt in the boiler furnace when biomass of energy crops are used.

Higher pyrolysis temperature was used during experimental studies to minimize to the maximum possible extent the quantity of sludge. The analysis of the pyrolysis product element distribution is presented, as well as the distribution of these elements in separate parts of the hemp fiber. Distribution of heavy metals, alkaline-earth metals and alkaline metals as well as of non-metals in sewage sludge products (after high temperature pyrolysis), and in separate parts of hemp when sewage sludge is used for fertilization, and assessment of biomass yield form **the study object** of this paper.

Aim of the work

Thermal degradation of anaerobically digested sewage sludge in an inert environment (pyrolysis) by determining the regularities of the distribution of basic and secondary elements in the produced products, and practical use of char derived from sewage sludge for soil fertilization taking into account the absorption of the elements into different parts of the fibre hemp (*Cannabis sativa L.*) such as roots, stem, leaves.

Tasks of the work

For implementation of the scientific goal, the following main tasks should be performed:

1. To determine the yield of generated sewage sludge pyrolysis products (char, tar, condensate and gas).
2. To perform chemical analysis of the produced pyrolysis products and determine the distribution of heavy metals, alkaline earth and alkali metals and non-metals in these products.
3. To use sewage sludge char generated during pyrolysis process as a fertilizer for the cultivation of fibre hemp (*Cannabis sativa L.*).
4. To assess the influence of char derived from sludge on the growth of the fibre hemp biomass, the absorption of the heavy metals, alkaline earth and alkali metals and non-metals in different parts of the plant (roots, stem, and leaves).

Relevance of the work

The quantities of sludge generated in the treatment plants already pose serious problems related to its storage and use. The Article 14 of the Urban Waste Water Treatment Directive 91/271/EEC specifies, “Sludge arising from waste water treatment shall be re-used whenever appropriate. Disposal routes shall minimize the adverse effects on the environment “. Therefore, priority is given to the reuse of sewage sludge, rather than taking to landfill or storage plants. Research has shown that pyrolysis is a major alternative to sewage sludge utilization. The pyrolysis process reduces the volume of raw material and generates valuable by-products that are concentrated and chemically stable, and pathogenic substances are destructed. For this reason, the further use of pyrolysis products in other areas is more acceptable than after other thermal processes. Also, knowing the distribution of elements, further use of pyrolysis products is possible. This would create an environmentally friendly process and would allow further reduction of the release of unwanted substances into the environment.

Novelty of the work

After the thermal decomposition of anaerobically digested sewage sludge the regularities of the distribution of heavy metals in pyrolysis products were described in detail, the mechanism of distribution of alkaline earth metals and alkaline metals and non-metals were investigated, the prospects for growing fibre hemp (*Cannabis sativa L.*) have been assessed through laboratory tests when sewage sludge and char derived from sewage sludge are used for fertilization.

Significance of research results

The sustainable aspect of use of sewage sludge has been assessed through the investigation. The main thrust of the aspect lies in the fact that the amount of sludge is significantly reduced by 2.5 times in the way of production of useful products which, given the quantities of pollutants, i.e. heavy metals, can be further adapted as an alternative raw material in other fields. The properties of fibre hemp (*Cannabis sativa L.*) to absorb heavy metals from the soil fertilized with sewage sludge and its products have been also assessed.

Statement presented for defence

1. After the pyrolysis process the volume of sewage sludge is reduced by 2 times most of the mass consists of char derived from sewage sludge;
2. After the pyrolysis process heavy metals, alkaline earth and alkaline metals as well as of other metals are immobilized in the char derived from sewage sludge;
3. Increasing amounts of fertilisers, sewage sludge or sewage sludge char, the biomass yield of fibre hemp increased just at the particular amounts of these fertilisers, at the optimum fertilization yields the highest biomass yield is achieved, further increasing these amounts the biomass yield decreased.
4. Increasing amounts of sewage sludge char as fertilizer in soil, this leads to increase levels of alkaline earth metals and alkaline metals in fibre hemp but heavy metal levels decreased.

Author's contribution in analysed problem

The analysis of scientific literature related to the quantities of sewage sludge and its chemical composition, the possibilities of its use in thermal products and the possibilities of the use of the resulting products in other areas as a raw material had been carried out by the author of dissertation. The sewage sludge samples have been collected by the author of the dissertation from the major water treatment systems of Lithuania during the preparation of the dissertation. Having evaluated their quality, the author has selected the sewage sludge samples from a small city for the more detailed research. The author has designed and constructed a

pyrolysis stand where he has carried out thermal decomposition of sewage sludge. He has used a hard fraction obtained and char derived from sewage sludge in experimental research on cultivation of fibre hemp. In order to assess the regularities of distribution of heavy metals, alkaline earth metals and alkaline metals as well as of non-metals the author has carried out the chemical analyses of sewage sludge, sludge pyrolysis products, parts of fibre hemp (roots, stem, leaves) and soil. The author has found out according to the obtained results of the experiment the regularities of the element migration in the course of the application of the principle of sustainable use of sewage sludge.

Scientific approbation of dissertation

Research results presented in the dissertation were published in 2 scientific articles in publications with a citation index at the „Clarivate Analytics“ database „Web of Science Core Collection“. Research results were also presented at 8 conferences, 6 of them international ones.

1. LITERATURE REVIEW

Biomass and organic waste are considered to be the main substitutes for fossil fuels. Advanced technologies (in industry, agriculture, households) are developed to meet the growing demand for renewable energy. Sewage sludge is a residual waste water treatment product with recently increasing quantities. The sewage sludge suspension ranges from 0.25% to 12% of dry matter in the total flow of sewage, depending on the wastewater treatment process. Due to the strengthened requirements of the European Union concerning urban wastewater treatment, the amount of sewage sludge has recently increased significantly. For this reason, the issue of the secondary use of sewage sludge has taken on particular significance. Such forms of sludge disposal as disposal in landfills, burning and composting are the most common methods of sewage sludge disposal. Landfills are considered to be the simplest solution for disposing sewage sludge as it is a relatively cheap way of disposal. Sludge storage grounds have a limited volume and in order to avoid hazardous substances from entering a soil the installation of such sites is subject to the most stringent environmental requirements. The use of sewage sludge is currently limited as both technological and environmental as well as social problems are encountered. The attractiveness of sludge as a product suitable for the generation energy source is hidden in the fact that it can be used as a renewable source of energy. There are two main arguments in terms of use of such fuel: it is an alternative to fossil fuels and reduction of greenhouse gas emissions.

The undesirable properties of biologically, chemically or heat treated, long kept (in storage grounds) or otherwise properly treated sewage sludge are reduced. The use of such sewage sludge in further processes is more acceptable. The European Union directive provides for sewage sludge to be used in such a way as to ensure the absorption of nutrients into plants, and not to impair the quality of soil, surface water and groundwater.

For this reason, the document specifies precisely the methods for treatment of sewage sludge, permitted quantities in agriculture, chemical composition and the prospects for use. A particular attention is given to the regulation of heavy metals in the untreated and treated sewage sludge.

The literature review addresses three main aspects of sewage sludge: processing and utilization possibilities, physicochemical properties of sewage sludge, the use of thermal products as a possibility of raw materials. Main focus is given to heavy metal concentrations in sewage sludge arising from wastewater treatment. This choice has been driven by the fact that the volumes of sewage sludge are significantly increasing, and its use is impeded namely by increased concentrations of heavy metals. For this reason, only a small portion of sewage sludge is used as a product, and the rest is accumulated in the storage grounds or landfills.

The research works include the data about the practices of use of sewage sludge that are popular in other countries, problem solving methods and benefits

from technologies applied. The works reviewed cover a wide range of heavy metal issues, their distribution in thermal process products and the potential for further use of the resulting products. The research carried out show that there is not enough reliable information on the distribution of heavy metals in pyrolysis products. When summarizing the results of the research it can be seen that there exists a very wide range of results, though research projects are carried out under the same conditions. Removal with pyrolysis gas has not been evaluated. There are no research dealing with the mechanisms of distribution of alkaline earth metals and alkaline metals in pyrolysis products. There are no data in Lithuania about the prospects for growing fibre hemp fertilized with sewage sludge and char derived from sewage sludge because its cultivation has been legalized by law only in 2014.

After reviewing the literature sources, the decision was made to carry out a stepwise research on the use of sewage sludge by evaluating the regularities of the distribution of heavy metals, alkaline earth metals and alkaline metals and non-metals in the following sequence: sewage sludge → pyrolysis products (char derived from sludge, resins, condensate, synthetic gases) → soil → hem (roots, stem, leaves). Sewage sludge from a small city (Šilutė) has been selected for research as it contains smaller concentrations of pollutants compared to larger cities. Fibre hemp has been selected as a potential energy plant with a high biomass gain and showing the ability of accumulating heavy metals from a soil.

In view of the experience of other scientists and the results obtained the decision was made to carry out the following experiments:

- A pyrolysis analysis of dried and anaerobically digested sewage sludge at a temperature of 850 ° C by recording the yield of the resulting products by weight, and the instantaneous composition of the resulting gases. The analysis will enable determination of the quantities of solid, liquid and gaseous pyrolysis products generated.
- Determination of elemental composition in sewage sludge and sludge pyrolysis products in order to evaluate the regularities of distribution, saturation and extraction of heavy metals, alkaline earth metals and alkaline metals and non-metals.
- Fibre hemp cultivation experiment under laboratory conditions using 25, 50, 100 and 200 t / ha of sewage sludge and char derived from sewage sludge for fertilization in order to assess the impact of fertilization on biomass gain and biometric parameters.
- Determination of the elemental composition of the individual parts of fibre hemp such as roots, stem, leaves in order to assess the ability of fibre hemp to absorb heavy metals, alkaline earth metals and alkaline metals as well as non-metals from a soil.

As direct use of sewage sludge is hampered by increased concentrations of pollutants, the regularities of migration of heavy metals describing a

characteristic delay in the selected route of the use of sewage sludge will be presented after the accomplishment of the research and evaluating the results obtained.

2. EXPERIMENTAL SETUP AND METHODOLOGY

Since the research dissertation work consists of two parts, a scheme in figure 1 step by step presents the experimental study performed that are necessary for solving the tasks set. Consistent research methods are presented in sections 2.1 and 2.2 below.

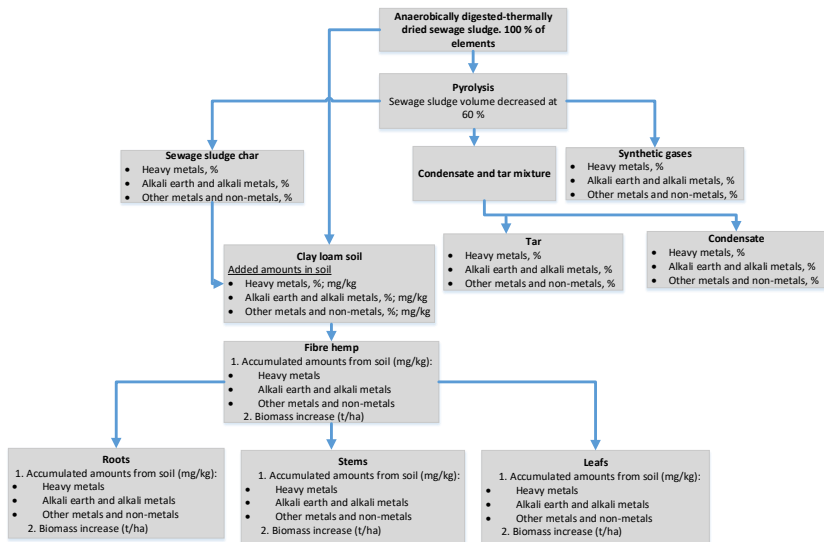

Fig. 1. The main steps of experimental work

Physical-chemical parameters of anaerobically digested and dried sewage sludge have been identified in part one of the study. These studies have been carried out in order to assess the properties of sewage sludge as the primary material. The main focus was on the elemental composition of sewage sludge, which was divided into three groups: 1) heavy metals, 2) alkaline earth and alkaline metals, 3) and other metals and non-metals. This was followed by thermal processing of sewage sludge – pyrolysis. During pyrolysis process sewage sludge was degraded in an inert environment, by reducing its volume. Percentage allocation of the resulting products, i.e. sludge char, tar, condensate and gas, has been determined after pyrolysis process. Quantities of the same elements as in the primary material, i.e. in sewage sludge, have been determined through the study in the char, tar and condensate. Subsequently, the balance calculations of the

elements determined in the said products have been carried out. The removal of the selected elements with gas products has been determined following the assessment of the balance differences.

In the second part of the study, the generated sewage sludge char has been used for growing the hemp. A biomass gains of the hemp, absorption of elements from soil and distribution into separate parts of the hemp, such as roots, stem, leaves, have been assessed. The accumulation factor of the elements analysed in the parts of the hemp under the conditions of intensified fertilization with sewage sludge and sludge char has been determined.

2.1 Investigation of pyrolysis process

2.1.1 The methodology for experimental investigation of sewage sludge during pyrolysis

The schematic diagram of the experimental setup is presented in Fig. 2. A vertical, batch-type pyrolysis reactor was designed in the laboratory and used to conduct experiments. The pyrolysis chamber had an internal diameter of 5 cm and a length of 85 cm. The process temperatures were controlled with PicoLog software using a thermocouple positioned at the center of the reactor in the pyrolysis chamber.

Anaerobically digested, thermally dried sewage sludge (compressed as SS) was obtained from a wastewater treatment plant located in Šilutė (Lithuania) for use in this study. The sludge sample (Table 1) had a particle size in the 5–20 mm range and was not ground and sieved prior to feeding into the pyrolysis reactor. Dry sewage sludge (300 grams) was loaded into a laboratory-scale reactor. The feed of the material was flushed with nitrogen gas for 3 min at a constant flow rate of 4 L/min to obtain an oxygen-free atmosphere. The temperature program was set to heat at a constant heating rate of 15 °C/min to achieve the set-point temperature (850 °C), and the reactor was maintained at this temperature for approximately 90 min. The pyrolysis experiments were performed at atmospheric pressure. The condensable tar and condensate mixture was weighed directly during the pyrolysis process with a Kern balance, and data was recorded with KernBC2006 software. The gases generated by the pyrolysis reaction were first allowed to pass through a cold trap to condense the tar. Non-condensable gases—H₂, CO, CO₂, and CH₄—were analyzed online with the VISIT 03H analyzer and Win-Data 3 software.

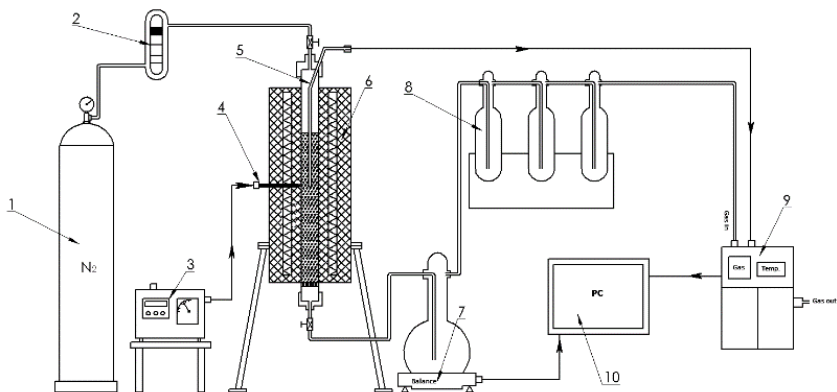

Fig. 2. The schematic configuration of pyrolysis experiment. 1. Nitrogen gas 2. Flowmeter 3. Temperature controller 4. Thermocouple of reactor 5. Thermocouple of sludge feed 6. Furnance 7. Balance 8. Ice bath 9. Gas analyzer 10. PC

Nitrogen gas was used as the carrier gas at a rate of 6 L/min to maintain an inert atmosphere. This flow rate was considered sufficient to prevent the accumulation of the pyrolysis gas that was generated and to have no effect on the temperature of the surface of the sediment sample. After each run, the furnace was turned off, and the reactor was allowed to cool naturally to room temperature. The cooled samples were collected, and the masses of the sludge, char, tar and condensate in the samples were determined. Then, the samples were subjected to elemental and heavy metal analyses. The syngas mass was calculated by finding the difference.

The experiment was repeated at least five times to ensure the reliability of the mass balance and data. The data are reported in this paper as the mean value of five replicates.

2.1.2 Material characterization and elemental analysis

Laboratory samples (300 g) of SS were taken randomly from a large bag with a pipe (spear). Sewage sludge char (compressed as SSCh) portions, approximately half of the sample after pyrolysis, were taken from all five replicates. After pyrolysis, the condensable tar and condensate mixture were obtained. The condensable tar and condensate mixture consisted of heterogeneous compounds, such as heavy tar and water that separate into different layers according to density. The mixture was centrifuged and separated using laboratory funnels. The separated tar and condensate were prepared in portions for laboratory samples (approximately 3 ml) for further determination.

From the collected sludge and char samples, the moisture content was identified according to specification CEN/TS 15414-1:2010, and the ash content

in the sludge, char, tar and condensate was determined according to the standard LST EN 15403:2011 method. Proximate analysis to determine the weight percentage of volatile matter was conducted using a TGA 4000 with a simultaneous TGA/DTA analytical method. The fixed carbon content was calculated from the difference. The analysis of C, H, N and S present in the solutions was performed using a Flash 2000 analyser. The C, H and N contents were determined according to the standard LST EN 15407:2011 method. The O content was calculated from the difference. The Cl and S contents were estimated using an ISC-5000 DC ion chromatographic system according to the standard LST EN 15408:2011 method. The high heat value (HHV) for the solution was determined using an IKA C5000 calorimeter according to the standard LST EN 15400:2011 method for automated bomb calorimeters.

The obtained samples of the sewage sludge, char, tar and condensate were mineralized for determination of the selected metals. At the first mineralization step, the test samples (approximately 0.2 – 0.4 g of laboratory samples) were flooded with 3 ml of concentrated nitric acid, 3 ml of hydrofluoric acid and 1 ml of hydrochloric acid. The samples (in triplicate) were placed in a mineralizer and mineralized for 1 h and 10 min (at 800 W, 6 MPa, pRate: 50 kPa/s), with 10 min allocated for heating, 45 min for mineralization (in accordance with established parameters) and 15 min for cooling. After the second mineralization, the samples were flooded with 18 ml of boric acid (H₃BO₃ to avoid and eliminate fluoride toxicity) and again placed into a mineralizer for 1 h and 10 min (at 800 W, 6 MPa, pRate: 30 kPa/s). After mineralization, the solution was poured into 50 ml flasks and diluted to 50 ml using deionized water. The analysis of the solutions (including determination of Al, As, Ca, Cd, Co, Cr, Cu, Fe, K, Mg, Mn, Na, Ni, P, Pb, S, Sb, Si, Ti, V, Zn, Ba, Be, and Se) prepared from the sewage sludge char, tar and condensate samples were performed using an ICP-OES according to the standards LST EN 15410:2011 and LST EN 15411:2011.

2.2 Sewage sludge and sewage sludge char to fibre hemp (*Cannabis sativa L.*) biomass production

Herm (*Cannabis sativa L.*) have been cultivated under laboratory conditions using sewage sludge and char derived from sludge after pyrolysis. The amount of sewage sludge and char for fertilization has been selected in accordance with requirements of LAND 20-2005: “Up to 33 t/ha of sludge (in the form of dry materials) can be spread out (inserted, etc.) per year for the energy cultures cultivated in Lithuania and up to 100 t/ha for re-cultivation of damaged areas”. Four different concentrations to a hectare have been selected for the experiment: 1 – 25 t/ha, 2 – 50 t/ha, 3 – 100 t/ha, 4 – 200 t/ha and a soil without fertilization (control). It should be noted that the legislation regulates only the amount of sewage sludge, and does not regulate the char content of sewage sludge. In order

to evaluate the distribution of results the cultivation in different fertilization doses was performed applying three replications.

The seeding and growing density of herm has been selected according to other research data. The studies carried out by Dutch, Italian and English scientists show that when 30 to 90 pcs of herm are seeded in one square meter, practically all herm seeded grows up at the end of the vegetation period. It has been found out that when 180 to 270 pcs of herm are seeded in one square meter, the seedlings of herm overshadow each other during the vegetation period. In such case 110-180 pcs of the seedlings seeded remain at the end of vegetation period in one square meter at the end of vegetation period. An optimal density of seeding – 65 pcs in one square meter has been selected during this research. Herm has been cultivated in pots (d – 20 cm, h – 20 cm). In this case 2 pcs of herm have been seeded in the pots.

The experiment has been carried under the laboratory conditions, in a climate chamber. A temperature of $21\text{ }^{\circ}\text{C} \pm 2\text{ }^{\circ}\text{C}$ and a relative humidity of 60% have been maintained during the experiment. The duration of the light intensity $256\text{ }\mu\text{mol} / (\text{m}^2 \cdot \text{s}^{-1})$ ranged from 10 h to 14 h daily. During the entire period of cultivation (4 months) herm has been watered twice a week. The herm has been unrooted at the end of the experiment and three separate portions have been formed, i.e. roots, stem and leaves. The roots have been washed with water to remove the attached particles of soil. The separated parts have been dried up to a constant mass at $105\text{ }^{\circ}\text{C}$ and have been prepared for further research.

3. RESULTS AND DISCUSSION

3.1 Results of pyrolysis process investigation

3.1.1 Chemical composition of the sewage sludge, char, tar and condensate

The sludge was characterized to relate the initial feedstock composition to the final product composition. The proximate and ultimate analyses of the anaerobically digested sewage sludge char, tar and condensate are presented in Table 1.

The sludge and char displayed very distinct chemical compositions. The high ash content indicates that: (1) very little elemental content runs into the gas-phase and liquid-phase, and the all of these elemental almost entirely remain in the solid-phase (Table 2); (2) the carbonaceous materials transform into hydrocarbon compounds, e.g., gas, aromatic hydrocarbons and tar¹⁰. Variations in the C, H, O, and N contents and H/C, O/C, and N/C ratios demonstrate that the organic matter during the pyrolysis process decreases. The carbon contents in the sewage sludge and its product differ. In the SSCh, the carbon content after the pyrolysis slightly decreased. The C content decreased approximately 6 %, which was confirmed by the mineral fractions being a dominant fraction in the initial SS and SSCh.

Table 1. Proximate and ultimate analysis of sewage sludge, sewage sludge char, tar and condensate.

Parameter	Sewage sludge	Sewage sludge char	Tar	Condensate
Ultimate analysis (wt. %)				
C, %	32.3 ± 0.26	25.97 ± 05	42.67 ± 1.44	7.88 ± 2.74
H, %	5.04 ± 0.13	0.4 ± 0.04	5.36 ± 0.19	1.05 ± 0.02
N, %	4.23 ± 0.42	1.3 ± 0.04	4.43 ± 0.05	2.36 ± 0.08
Sulfur, %	1.42 ± 0.04	0.08 ± 0.03	0.65 ± 0.03	0.47 ± 0.01
O (by difference), %	22.43	-	48.83	88.19
Cl, %	0.16 ± 0.05	0.27 ± 0.14	0.08 ± 0.01	0.004 ± 0.03
Proximate analysis (wt. %)				
volatile matter, %	39.55 ± 2.13	-	85.75 ± 1.40	5.90 ± 0.43
fixed carbon, %	22.98	24.25	-	-
ash, %	34.57 ± 0.04	71.41 ± 0.56	0.07 ± 0.01	0.046 ± 0.01
moisture, %	9.84 ± 0.02	4.34 ± 0.02	-	-
H/C	0.16	0.02	0.13	0.39
O/C	0.83	-	1.19	9.32
N/C	0.13	0.05	0.11	0.34
HHV, MJ/kg	13.5 ± 0.05	9.58 ± 2.82	33.05 ± 0.07	-

The ash content increased by two times after pyrolysis of SSCh (Table 1). A relatively high concentration of carbon was determined in the tar and influenced the high calorific value. The results showed that some carbonaceous products were transferred in the condensate. The content of H, N and O decreased significantly after pyrolysis of the biochar compared to that of the initial sewage sludge. The decrease in these elements did not show the same tendency. The ratio of H/C, which indicates the degree of carbonization in the sewage sludge, was always lower than 0.5, which suggested that biochar with a strong carbonization and high aromaticity can resist decomposition. These changes in the H/C and O/C ratios also illustrate that dehydrogenative polymerization and dehydrative polycondensation occur during pyrolysis with a significant loss of oxygen and aliphatic hydrogen. The N/C ratio has the same tendency as the H/C and O/C ratios. Comparing with the raw SS, the H/C and N/C ratios in the char and tar decrease but increase in the condensate. The O/C ratio of the char, tar and condensate compared with that of SS increases drastically from 1.43 in the tar to 11.23 in the condensate.

3.1.2 Elemental distribution in pyrolysis products

The distributions of selected elements in the sewage sludge, char, tar and condensate are presented in Table 2, and the percentage distributions are shown in Fig. 3. After investigation As, Sb, V and Se elements were not found in sewage

sludge and the further analysis in pyrolysis products was not made. The concentrations of most of the elements were higher in the char than in the sewage sludge sample. The exceptions were Cd, which was not detected, and Co and S, which had lower concentrations in the char than in the sludge. The increase in the concentrations of the other elements during sewage sludge pyrolysis is typically caused by the increased concentration of elements in the biochar samples due to the gradual loss of C, H and O. The concentrations of the elements in the tar and condensate were determined to be lower. In the tar, Ca, Cr, Ni, Ti, Ba and Si were below the detection limit. In the condensate, Cr, Ni, Ti, Ba and Si were below the detection limit.

Table 2. Element concentrations (mg/kg) in sewage sludge, sewage sludge char, tar and condensate after pyrolysis. The ranges in literature show the wide variation in sewage sludge of elements in general.

Element	Sewage sludge, mg/kg	Sewage sludge char, mg/kg	Tar, mg/kg	Condensate, mg/kg
Heavy metals				
Cd	6.17 ± 11.99	< 0.01	9.15 ± 12.71	2.84 ± 9.86
Co	20.09 ± 16.73	18.85 ± 18.25	12.35 ± 14.12	4.20 ± 10.94
Cr	52.07 ± 2.31	85.06 ± 14.60	< 0.01	< 0.01
Cu	124.37 ± 11.54	263.50 ± 2.48	23.86 ± 11.65	5.96 ± 5.34
Fe	20266 ± 10.26	42240 ± 6.53	132.03 ± 10.16	6.78 ± 10.99
Mn	1918 ± 9.17	4127 ± 8.22	5.77 ± 17.56	1.37 ± 13.03
Ni	17.39 ± 17.13	38.17 ± 4.18	< 0.01	< 0.01
Pb	73.77 ± 13.73	165.70 ± 9.46	16.43 ± 16.53	8.85 ± 7.28
Ti	919.07 ± 9.21	2137 ± 4.47	< 0.01	< 0.01
Zn	2610 ± 11.72	5049 ± 0.24	484.23 ± 9.50	41.28 ± 4.49
Alkaline earth and alkali metals				
Ba	461.70 ± 3.80	1037.33 ± 0.78	< 0.01	< 0.01
Be	8.59 ± 18.22	13.11 ± 17.94	8.18 ± 17.04	2.66 ± 10.39
Ca	40566 ± 9.99	81866 ± 5.08	< 0.01	7.10 ± 14.80
K	10299 ± 5.22	21060 ± 4.14	516.90 ± 1.18	69.51 ± 1.42
Mg	7300 ± 8.46	16472 ± 4.69	23.45 ± 2.88	8.02 ± 1.22
Na	3388.50 ± 1.73	7715 ± 0.99	76.83 ± 6.91	54.53 ± 2.44
Other metals non-metals				
Al	10715 ± 3.23	24490 ± 0.78	18.54 ± 2.93	8.40 ± 2.76
Si	75295 ± 2.28	168733 ± 2.59	< 0.01	< 0.01
P	27150 ± 0.94	59470 ± 1.43	64.64 ± 2.79	24.03 ± 10.36
S	2900 ± 3.41	365.10 ± 3.56	880.57 ± 4.78	290.63 ± 9.73

The results showed that the total elemental content in the SS varied greatly, with detected amounts in the order of: Si > Ca > P > Fe > Al > K > Mg > Na > S > Zn > Mn > Ti > Ba > Cu > Pb > Cr > Co > Ni > Be > Cd. Almost the same variation in the measured elements was determined in the SSCh. The variation could be influenced by the degradation and transformation of organic substances

in the SS. The concentrations in the SSCh increased, but the variation was almost the same as that in the SS. The element concentrations in the tar followed the order of: S > K > Zn > Fe > Na > P > Cu > Mg > Al > Pb > Co > Cd > Be > Mn. In the condensate, the order was: S > K > Na > Zn > P > Pb > Al > Mg > Ca > Fe > Cu > Co > Cd > Be > Mn.

Estimating the elemental distribution by percentages, the largest portion of SS and SSCh was composed of ash-forming elements, such as Si (37 %), Ca (20 %), P (13 %) and Fe (10 %). The percentage distribution of the main heavy metals, Co, Cr, Cu, Ni and Pb, in the overall mass balance was less than 1 %, and the Cd distribution in the overall mass balance was less than 0.01 %. The elemental variation in the liquid products was different from the elemental variation found in the case of SS or SSCh. The largest portion of the SST composition consisted of three elements, S (39 %), K (23 %) and Zn (21 %), and in the SSC, the composition consisted of S (54 %), K (13 %) and Na (10 %). The evaluation of the elements, especially the heavy metal distribution, showed that most of the metal remained in the sewage sludge char.

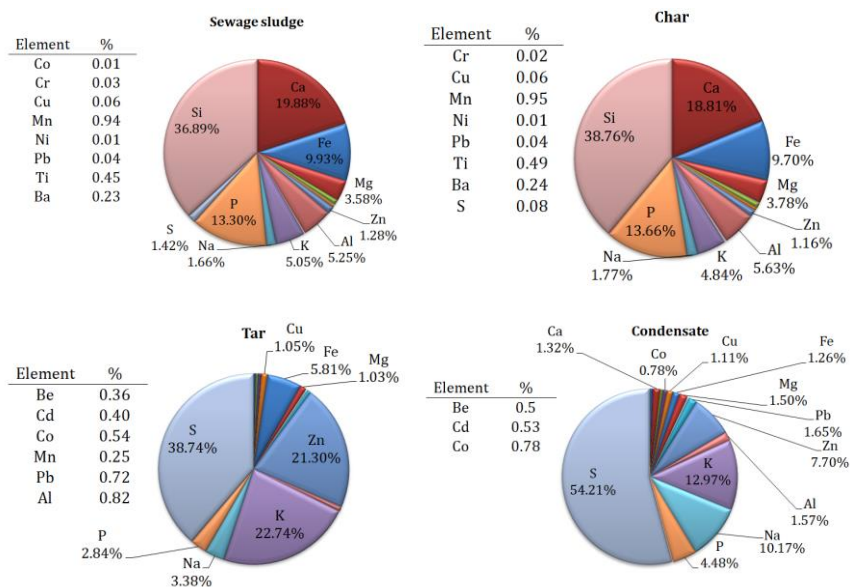

Fig. 3. Elemental distribution in sewage sludge, char, tar and condensate. The results in tables near the diagrams presented the values in range between 0.01 % and 1 %.

3.1.3 Relative enrichment of heavy metals and elemental recoveries

Relative enrichment (RE) factors help to identify the degree of enrichment of elements in the SSCh and reveal the volatility of trace elements. RE factors in SSCh greater than 1 indicate a larger enrichment of the trace element in the SSCh, and RE factors less than 1 indicate that the elements exhibit volatilization.

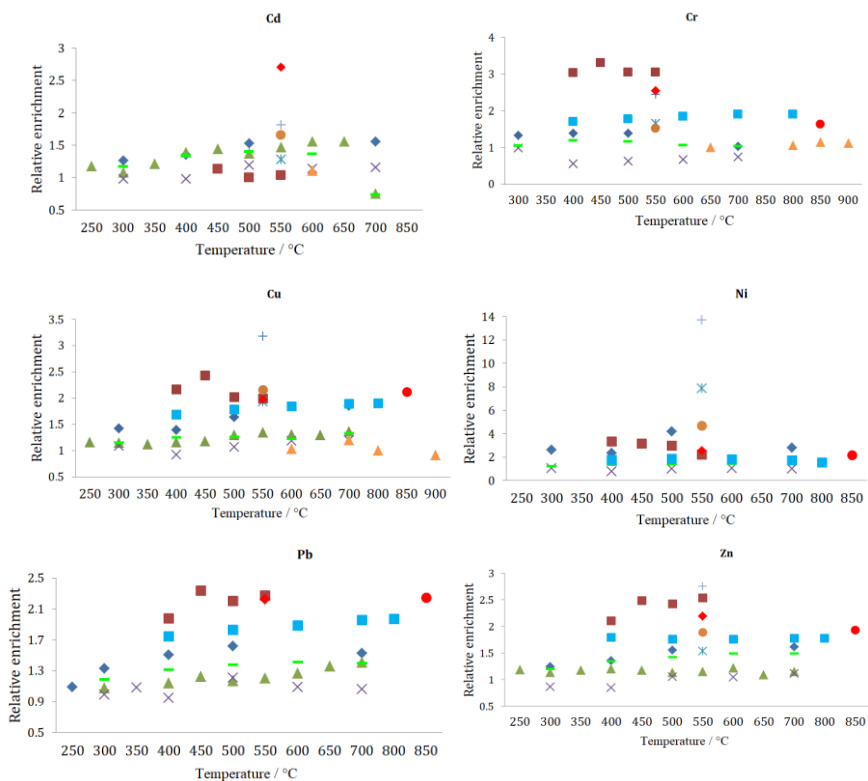

Fig. 4. Relative enrichment in different temperatures of Cd, Cr, Cu, Ni, Pb and Zn in sewage sludge chars after pyrolysis.

In this case, the relative enrichment factors were determined for Cd, Cr, Cu, Ni, Pb and Zn trace elements. These elements were chosen because their concentrations in sewage sludge are regulated by ES (86/278 EEC) requirements, and member states have transposed the European limits for sludge use into agriculture in their own regulations. Our results were compared with those of other studies to show how the temperature influences the different element enrichment in SSCh. The comparison of the RE factors for our results and the results obtained by other authors are presented in Fig. 4. A fixed-bed pyrolysis was performed in all studies, but the reactors were of different types, including infrared furnace, microwave oven and horizontal quartz and ceramic reactors. The temperature increase rate, gas flow and selected temperatures were different. The influence of the temperature on changes in the RE factor was further analysed.

An obvious difference between the increased RE factors of the elements in the range from 450 °C to 550 °C can be seen in the works of Song et al. (2014), Xie et al. (2014) and Hossain, Strezov, and Nelson (2009) (sample M). A relative enrichment of the heavy metals stands out in the general trend, and a significant increase in the RE values of Cr, Cu, Pb and Zn elements can be seen. Such a wide range of RE factors can be explained by the unequal conditions of the pyrolysis processes and different types of SS.

The assessment of relative enrichment of Cd showed the following trend. With increasing pyrolysis temperature, the RE factor also increased. The Cd concentration during our study was below the set limit of <0.01. Therefore, the RE was not determined. This low concentration could have resulted from the high temperature of 850 °C used during the pyrolysis process in our study because the Cd boiling temperature is 767 °C. Calculations of the element recoveries (Table 3) showed that a large percentage (68.17 %) of Cd was removed from the wastewater sludge with the gas products. For this reason, Cd could not be detected in the SSCh, and the concentration of Cd detected in the tar and the condensate was very low.

The assessment of the dependence of the RE factor for Cu, Pb and Zn on temperature showed that increasing the temperature increased the RE factor. The results of our study are significantly higher compared to those in the works of other authors due to a higher pyrolysis temperature. The results of our experiment followed the same trend as the results of F. Chen et al. (2015). In this case, the RE factor of Cu increased from 1.15 at 250 °C to 1.8 at 700 °C (Fig. 4), and the RE factor determined in our work was significantly higher, i.e., 2.12. The increase in the RE factor of Pb resulting from increase in the temperature was also obvious. The RE factor of Pb at 250 °C was 1.09, and when the pyrolysis temperature was 700 °C, the RE factor was already 1.5. The results of our work show that upon increasing the pyrolysis temperature to 850 °C, the RE factor of Pb increased to 2.25. A similar trend was also determined for the RE factor of Zn, i.e., the increase in temperature during the pyrolysis process resulted in an increase in the RE factor.

The RE factor at 250 °C was 1.18 and increased to 1.61 at 700 °C. The differences between the Pb RE factors determined in our work and those in other works are not as high, i.e., a factor of 1.93 at 850 °C. The applied pyrolysis temperature is the main parameter that directly influences the properties of the pyrolysis products and the product distributions. Complex compounds with organic structures are decomposed due to the higher temperature. For this reason, the mass of the char significantly decreases, and the relative concentration of elements increases.

The changes in the RE factors of Cr and Ni resulting from the increase in the pyrolysis temperature were not consistent. Fig. 4 shows that when the temperature increased above 550 °C, the overall level of the RE factor decreased. The RE factor for Cr determined during this study was 1.63, and the RE factor of Ni was 2.2, which was lower in the overall context.

Mostly, the element recoveries after the pyrolysis process were determined in the SSCh. In this study, we performed analyses on the SSCh, SST and SSC. After the evaluation of errors, we also calculated the elemental recoveries in the gas phase.

The transfer characteristics of the heavy metals can be related to their respective boiling points and their corresponding forms in sludge, such as in chlorides, which vaporize easily, and in sulfides, which vaporize poorly¹¹. When the inorganic elemental analysis of the 850 °C sample is considered, it can be determined that most ash-forming elements (Al, Ca, Cl, Fe, K, Mg, Na, P and Si) and heavy metals (Co, Cr, Cu, Ni, Pb, Zn, etc.) are concentrated in the char product. The contents of all of the analysed elements (Al, C, Ca, Cd, Cl, Co, Cr, Cu, Fe, H, K, Mg, Mn, N, Na, Ni, P, Pb, S, Si, Ti, Zn, Ba and Be) in the char, tar and condensate as well as the recovered fractions are shown in Table 3.

During the sludge pyrolysis at 850 °C, most of the heavy metals (Co, Cr, Cu, Ni, Pb, Zn, and Ti) remained in the char (elemental recoveries varied from 39.51 to 95.24 %). The same tendency was observed with alkaline earth and alkali metals (Be, Ca, Mg, Ba, K, and Na) (63.93 – 98.03 %). The variations in the non-metals, P, S, Cl, C, H, and N, in the char were very different, ranging from 3.63 % for hydrogen to 95.59 % for phosphorus. The intermediate metals, such as Fe, Mn, Al and Si, in the char showed the greatest recovery, up to 90 %, which showed their good stability during the pyrolysis process.

The elemental recoveries in the tar and condensate were low. The heavy metal recoveries in the tar vary from 14.77 % (Cd) to 1.66 % (Zn) and from 13.32 % (Cd) to 0.45 % (Zn) in the condensate. Cr, Ni and Ti were below the detection limit. Alkaline earth and alkali metal recoveries were quite low compared with the heavy metal recoveries. The values of K, Mg and Na were lower than 1 %, with the exception of Be, for which the recoveries in the tar and condensate were 11.31 % and 9.86 %, respectively. The Ca in tar and the Ba in the tar and condensate were determined to be below the detection limit. In general, the non-metal recovery variation was the most abundant.

Table 3. Element recoveries of the 850 °C of char, tar, condensate and probable in gas (calculated by differences).

	Sewage sludge char (Wt. %)	Tar (Wt. %)	Condensate (Wt. %)	Sum avg., %	Sum avg. + std., %	Possi- bly in gas, %
Heavy metals						
Cd	> 0.01	14.77 ± 2.37	13.32 ± 1.37	28.10	31.83	68.17
Co	39.51 ± 8.23	7.03 ± 3.15	5.23 ± 2.34	51.77	65.49	34.51
Cr	66.39 ± 6.40	> 0.01	> 0.01	66.39	72.78	27.22
Cu	80.15 ± 4.62	2.24 ± 0.90	1.39 ± 0.51	83.77	89.80	10.20
Fe	92.10 ± 5.73	0.08 ± 0.05	0.01 ± 0.004	92.20	97.97	2.03
Mn	92.63 ± 7.15	0.03 ± 0.02	0.02 ± 0.01	92.68	99.86	0.14
Ni	95.29 ± 3.82	> 0.01	> 0.01	95.29	99.11	0.89
Pb	84.76 ± 7.84	3.35 ± 0.50	3.12 ± 0.40	91.23	99.97	0.03
Ti	93.82 ± 3.00	> 0.01	> 0.01	93.82	96.82	3.18
Zn	82.11 ± 6.20	1.66 ± 0.81	0.45 ± 0.19	84.22	91.43	8.57
Alkaline earth and alkali metals						
Ba	98.03 ± 1.46	> 0.01	> 0.01	98.03	99.49	0.51
Be	63.93 ± 7.47	11.31 ± 4.35	9.86 ± 3.38	85.09	100.29	-0.29
Ca	84.68 ± 11.36	> 0.01	0.01 ± 0.003	84.69	96.05	3.95
K	88.52 ± 2.40	0.42 ± 0.08	0.21 ± 0.05	89.15	91.68	8.32
Mg	92.53 ± 6.72	0.03 ± 0.02	0.04 ± 0.02	92.61	99.37	0.63
Na	97.41 ± 2.44	0.26 ± 0.04	0.23 ± 0.03	97.90	100.41	-0.41
Other metals and non metals						
Al	99.12 ± 1.48	0.01 ± 0.01	0.02 ± 0.02	99.14	100.65	-0.65
Si	99.85 ± 0.35	> 0.01	> 0.01	99.85	100.20	-0.20
C	34.86 ± 3.14	11.67 ± 0.65	4.84 ± 0.24	51.36	55.40	44.60
Cl	85.98 ± 1.91	4.34 ± 0.80	0.51 ± 0.003	90.83	93.55	6.45
H	3.63 ± 0.09	8.22 ± 0.73	3.59 ± 0.98	15.44	17.25	82.75
N	16.30 ± 3.94	7.48 ± 1.47	11.12 ± 0.97	34.90	41.29	58.71
P	95.59 ± 3.15	0.02 ± 0.01	0.02 ± 0.001	95.63	98.78	1.22
S	5.75 ± 0.73	2.36 ± 0.19	2.14 ± 0.30	10.25	11.47	88.53

The highest values of the non-metal recovery were C > H > N > Cl > S in the tar. In the condensate, the highest non-metal recoveries were N > C > H > S. The phosphorus recovery was lower than 1 % for both the tar and condensate.

One of the factors which could make influence to incomplete recovery of metallic elements in pyrolysis products might be mass balance obtained for the samples¹⁹. From the calculations performed during this experiment, a high recovery was determined for Cd – 68.17 %, Co – 34.51 % and Cr – 27.22 %. Our findings show that the metal recovery from the sludge depends on the corresponding form of the metal in the sludge (mostly chlorides)⁴⁶ and on specific characteristics of the elements. These elements are presented as volatile (Cd) or semi-volatile (Co, Cr) heavy metals. The calculations showed that the Cu and Zn recoveries were also quite high, at 10.20 % and 8.57 %, respectively.

3.2 Results of fibre hemp fertilisation of sewage sludge and sludge char

3.2.1 Biometric parameters of fibre hemp

Cultivation of fibre hemp for energy purposes is a relatively new agricultural branch that requires knowledge about the optimal fertilization rates to get as much biomass as possible. The energy value of the biomass obtained is another important indicator. It is the main parameter of energy plants. The change in biomass gain under different intensities of fertilization has been quantified taking into account the concentrations of heavy metals in the soil after fertilization and their concentrations in the parts of the plants.



Fig. 5. Experimental investigation of fibre hemp biomass production in laboratory conditions

The total dry biomass of fibre hemp and other morphological parameters are presented in Table 4. The research data presented in the table show the influence of sewage sludge used for fertilization and char derived from sewage sludge for biomass influence. The data presented in the table show what rates used had a positive impact on biomass gain and which ones have a negative impact. The quantities of fibre hemp biomass obtained were significantly lower during this research compared to the results of other authors. The comparison of biomass influence with the results of other research using sewage sludge for fertilization or char derived from sewage sludge is a conditional matter. Assessing biomass gain is not very objective due to a different chemical composition of sewage sludge and char derived from sewage sludge. The main problem using sewage sludge and char derived from sewage sludge for fertilization of energy plantations is that such sludge contains too little potassium that is insufficient for plant growth. For this reason, mineral potassium contained in fertilizers is used for soil fertilization. The soil selected was relatively poor because of its chemical properties. A seeding density is another important parameter, i.e. a wrongly selected seeding density

leads to reduced biomass gain and its quality. Biomass gain of herm also depends on the environmental conditions and the cultivation model selected.

Table 4. Biometric parameters of fibre hemp in different fertilizations

	Above-ground high, cm	Root length, cm	Stem mass (d.m), kg/ha	Leaf mass (d.m), kg/ha	Above-ground mass (d.m), kg/ha	Root mass (d.m), kg/ha
Control	98 ± 15	36 ± 4	860 ± 50	620 ± 21	1480 ± 70	250 ± 13
25SS	113 ± 2	33 ± 2	1800 ± 29	3020 ± 37	4820 ± 32	380 ± 10
50SS	47 ± 13	23 ± 6	260 ± 26	550 ± 49	810 ± 75	30 ± 9
100SS	31 ± 6	25 ± 8	110 ± 11	190 ± 24	290 ± 35	30 ± 3
200SS	-	-	-	-	-	-
25Ch	67 ± 7	19 ± 3	520 ± 76	340 ± 33	860 ± 91	120 ± 17
50Ch	46 ± 3	18 ± 4	500 ± 63	400 ± 32	900 ± 93	90 ± 10
100Ch	29 ± 2	15 ± 5	100 ± 15	190 ± 19	290 ± 34	20 ± 3
200Ch	20 ± 2	10 ± 2	23 ± 2	64 ± 5	64 ± 5	4 ± 0.4

It is important to mention that herm did not grow and no biomass gain has been determined when a rate of 200 t/ha of sewage sludge has been used for fertilization. The further analysis using this rate of sewage sludge is not carried out.

A three times higher increase in biomass than in a blank control has been determined when a soil has been fertilized with sewage sludge at a rate of 25 t/ha. Further increase in fertilization intensity resulted in significantly decreased biomass gain, and in the maximum fertilization rate no fibre hemp has grown up. The biggest biomass gain has been determined at 50 t/ha rate using char derived from sewage sludge for fertilization. However, it was significantly lower compared to biomass gain when a fertilization rate of sewage sludge was 25 t/ha. Continued increase of fertilization intensity, same as sewage sludge, resulted in a significant decrease in biomass gain. Fibre hemp survived at the maximum rate of char derived from sludge, but biomass gain was absolutely insignificant. It is important to mention that compared to a blank control biomass gain was higher only when a sewage sludge rate was 25 t/ha, while all other fertilizations have had a negative impact on biomass gain. It can be said that fertilization with sewage sludge and fertilization with char derived from sewage sludge exceeding 25 t/ha is completely useless and unnecessary. In this case, the need to carry out further research using sludge rates below 25 t / ha for fertilization arises, and to enrich char derived from sewage sludge with additional microelements, such as potassium.



Fig. 6. Root length in different fertilizations of sewage sludge and sewage sludge char

When assessing other morphological parameters such as the height of the stem or the length of the roots and the biomass, it can be seen that fertilization with sewage sludge and char derived from sludge had a different effect. Increase of amount of sewage sludge or char derived from sludge resulted for the most part in decline of the aforementioned parameters in the soil. Only a 25 t/ha rate of sewage sludge had positive effects compared to a blank control. The average increase in height of stems was 15 cm, the roots at this rate of fertilization were slightly shorter (around 3 cm), however biomass was about 130 g higher. All other fertilization rates had a negative effect on the height of fibre hemp's stem, the length of the roots and amount of biomass. The results of the research show that additional amount of these substances causes fibre hemp stress, which is usually due to heavy metals.

3.2.2 Accumulation factor to fibre hemp parts

Accumulation factor (AF) defined as a coefficient, which shows what quantities of elements a plant is able to absorb to its different parts from a soil. This factor defines the ability of individual elements to accumulate in certain parts, regardless of whether the fertilizer is used at high or low concentrations. The rates of sewage sludge or char derived from sludge required for gaining the biggest biomass and for ensuring the maximum removal of hazardous substances (e.g. heavy metals) from a soil are determined based on this criterion. The higher the value of this coefficient, the greater the amount of elements from the soil can be absorbed by the plant compared to its primary amount in the soil. According to the literature, the accumulation factor in the parts of the plant is divided into four groups:

- $AF < 0.01$ – the element is not accumulated in the plant;
- $0.01 < AF < 0.1$ – low level of accumulation;
- $0.1 < AF < 1.0$ – average level of accumulation;
- $AF > 1$ – high level of accumulation.

The change of heavy metal accumulation factor to the parts of herm is presented in Figure 7. The results obtained show that the ability of herm to accumulate heavy metals in the individual parts differs with increasing fertilization intensity.

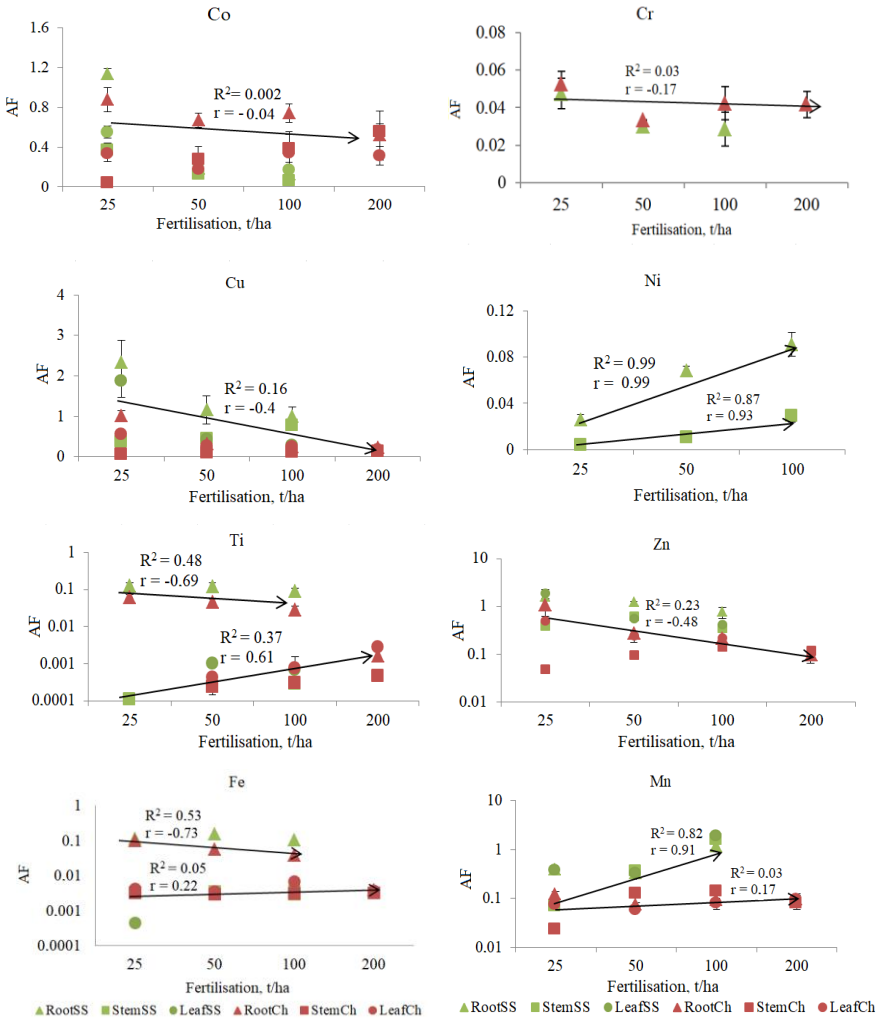

Fig. 7. The influence of added dose of sewage sludge and sewage sludge char to heavy metal accumulation factor in different parts of fibre hemp

When the amount of sewage sludge or char derived from sludge increases, accumulation of the same metal in the parts of herm can decrease or increase in all

parts of the plant. In some cases, accumulation of the same metal in some part of the plant increases while in other parts it decreases or remains constant. The total determined level of heavy metal accumulation factor was low or average, regardless of the fertilizer agent. In some cases, when a fertilization rate was 25 t/ha, a high level of accumulation of Co, Cu and Zn in the parts of herm has been determined.

The results of the research show that the total level of Co accumulation in the parts of herm is average. As the intensity of fertilization increases, the absorption to the individual parts of herm remains unchanged, $R^2 = 0.002$, and the increase in fertilization does not affect the accumulation of cobalt in the individual parts of herm, $r = -0.02$. The determined level of Cr accumulation in the roots of herm is low and there is a slight change in AF with increasing fertilization intensity, $R^2 = 0.03$. Same as in case of Co, the increased fertilization does affect accumulation of chromium in the roots of herm, $r = -0.17$. Compared to other heavy metals, the overall level of copper accumulation in the parts of herm is high. However, as the intensity of fertilization increases, it gradually decreases, $r = -0.4$. A moderate correlation has been established. It shows that herm absorbs less copper when amount of sewage sludge or char derived from sludge is increased. Analysis of nickel AF in individual parts of herm showed that accumulation of nickel in the roots and stems differs when fertilization intensity increases. When fertilization rate increases, the absorption of Ni in the roots increases very rapidly, $r = 0.99$. When a rate of sewage sludge increases, absorption of Ni in the stems increases equally fast. However, intensity is less than intensity in the roots, $r = 0.87$. A strong positive correlation between the intensity of fertilization and the amount of Ni accumulated in the roots and stems has been determined in both cases. The analysis of titanium AF dependence on fertilization intensity shows obvious differences between roots, stems and leaves. This element is not accumulated in the stems and leaves $AF < 0.01$, whereas a low level of accumulation of this element has been determined in the roots. As the intensity of fertilization with sewage sludge or char derived from sludge increases, accumulation of Ti in the roots decreases $r = -0.69$, while in the stems and leaves its accumulation increases $r = 0.61$. A strong correlation between fertilization intensity and the amount of Ti accumulated in the parts of herm has been determined for these groups, $0.3 < |r| \leq 0.6$. Accumulation of zinc in all parts of herm is the same; as the intensity of fertilization increases, Zn accumulation factor decreases, $r = -0.48$. A moderate correlation between fertilization intensity and decrease of AF in the parts of herm has been determined. When sewage sludge is used for fertilization, the level of zinc accumulation in the parts of herm is high or moderate, and when char derived from sludge is used for fertilization, the level of zinc accumulation in the parts of herm is moderate or low. Same as in the case of titanium, the highest AF of iron is in the roots. However, it significantly decreases with the increasing intensity of fertilization, $r = -0.73$. A slight correlation $r = 0.22$ between fertilization intensity

and the accumulated amount of Fe has been determined in the stems and leaves. The results show that a low level of iron will be accumulated in the roots as fertilization with sewage sludge and char derived from sludge increases. The level of the accumulation of this metal is low. The amount of Fe will not be accumulated in other parts, $AF < 0.01$. The amount of Fe will not be accumulated in other parts, $AF < 0.01$. The levels of accumulation of manganese in the parts of herm are different when sewage sludge and char derived from sludge are used for fertilization. The level of accumulation of Mn in all parts of herm increases significantly with the increasing level of sewage sludge, $r = 0.91$, and when char derived from sludge is used for fertilization, the amounts of Mn are equal irrespective of fertilization dose $r = 0.17$. The level of Mn accumulation increases from an average to high with the increasing amount of sewage sludge, whereas the level of Mn accumulation does not change and is low with the increasing level of char derived from sludge.

Research show that when sewage sludge or char derived from sludge are used after pyrolysis process, the increase of fertilization intensity has the greatest influence on Ni, Ti, Fe and Mn absorption.

AF of alkaline earth metals and alkaline metals (Figure 8) has increased for Ba, Ca, K, Mg elements with the intensified fertilization with sewage sludge and char derived from sewage sludge irrespective of a part of herm. The distribution of accumulation factor by different parts has been determined for Na. The highest AF has been determined in the roots, while the lowest accumulation has been determined in the leaves.

With the increasing fertilization with sewage sludge and char derived from sewage sludge, Ba, Ca and Mg accumulation factor also increases. A strong positive correlation between a fertilization dose and AF has been determined for all elements, respectively $r = 0.79$, $r = 0.8$ and $r = 0.68$. Accumulation of potassium in the parts of herm increases with the increasing amount of fertilization agent. However, there is a moderate correlation between AF and the agent dose, i.e. $r = 0.55$.

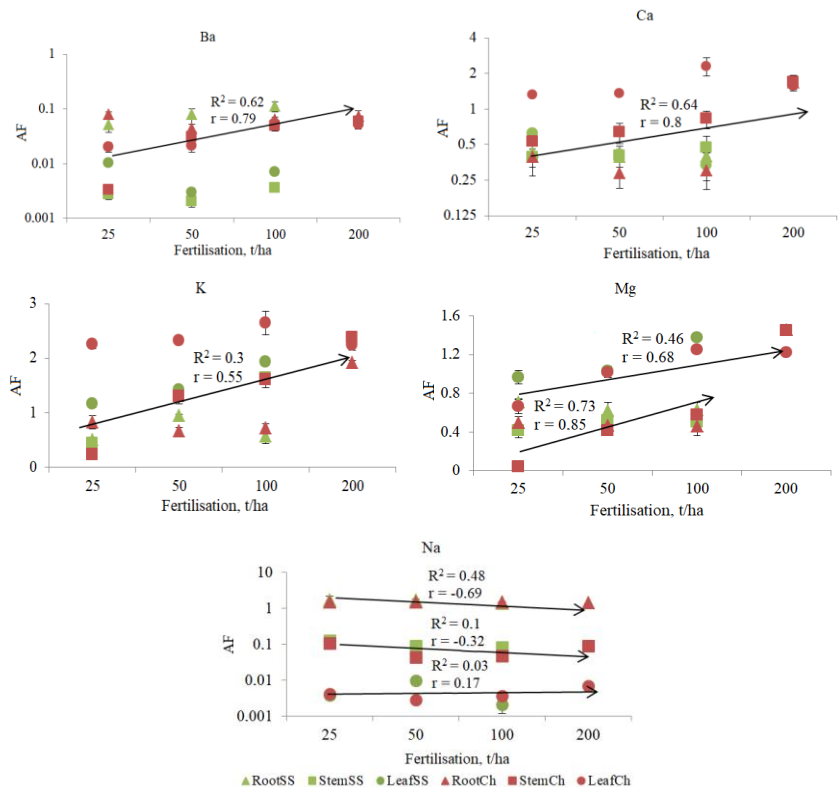

Fig. 8. The influence of added dose of sewage sludge and sewage sludge char to alkaline earth and alkali metals accumulation factor in different parts of fibre hemp

Other elements, such as Al, Si, P and S, may also affect the formation of pollutants. For example, the sulfur content acts as a catalyst and increases the amount of chlorine compounds which can cause corrosion of boilers. Consequently, it is also important to take into account the accumulation factors of these elements (Figure 9) in order to assess the compounds that are likely to occur during combustion. These elements and their compounds resulting from burning may cause problems of furnace, for example slagging, soiling and corrosion.

The study revealed that in the case of an increase in the intensity of fertilization with sewage sludge or sludge char, the accumulation factors of the elements analysed increase. There is an exception related to Al whose accumulation in the roots significantly decreases under the conditions of intensified fertilization. The assessment based on AF shows that Al and Si are not accumulated in the parts of the hemp, $AF < 0.01$ or accumulation level is low

0.01 < AF < 0.1. The accumulation of phosphorus and sulfur in the parts of the hemp is significantly higher. The average and high level of accumulation has been determined. A strong relation between fertilization intensity and the accumulated elements Al, Si and P in the parts of the hemp has been determined, $r > 0.6$. The accumulation of sulfur in the parts of the hemp is less intensive. Under the conditions of the increased fertilization the accumulation factor increases gradually, but not as intensively as Al, Si or P. A moderate correlation between fertilization intensity and increase of AF has been determined.

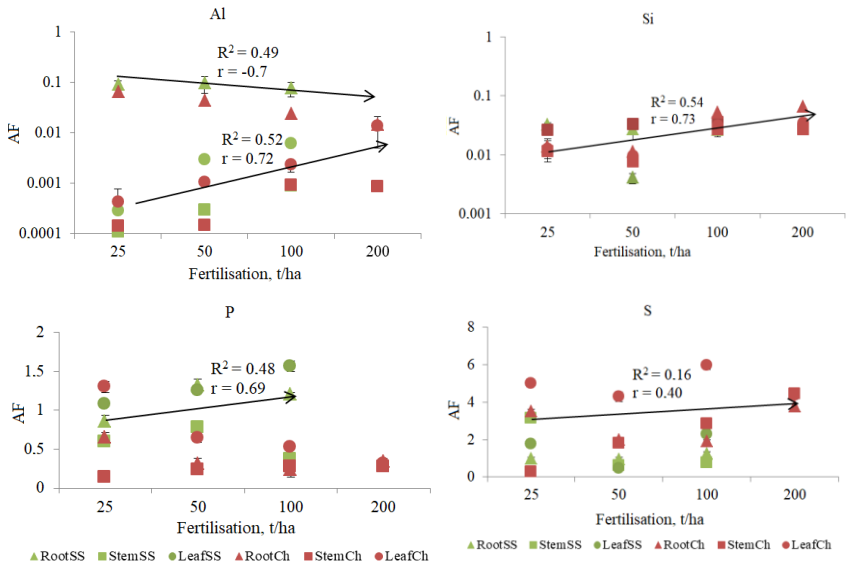

Fig. 9 The influence of added dose of sewage sludge and sewage sludge char to other metals and non-metals accumulation factor in different parts of fibre hemp

3.3 Practical possibilities of using the results obtained

It will be possible to apply in practice the results of the study obtained during the dissertation not only in the fields described in this thesis but also in other fields that are not directly related to the results of this thesis.

- The first part of the thesis where thermal decomposition of sewage sludge has been carried out during pyrolysis, can be used in dealing with the problem of reducing the volume of sewage sludge. Only about 40 % of hard part of the initial content remains after pyrolysis of sewage sludge at 850° C, i.e. sewage sludge volume is reduced by 2.4 times. Such volume reduction would significantly contribute to durability of the period of use of dried sewage sludge storage sites.

- The pyrolysis products obtained can be used in other sectors as raw material. Gas products after improving their quality, i.e. after clearing out the unwanted components, can be used for direct burning as constantly renewable energy resource. A solid fraction can be used not only as fertilizer for fertilizing energy crops, as presented in this study, but also in other fields. Sewage sludge char can be used as a source of chemicals (e.g. K, P) in production of absorbents, a raw material for energy generation, for production of activated carbon and catalysts. The liquid pyrolysis products can be used to produce bio-fuels and biofuels. This helps reducing the use of fossil fuels.
- The main application of the results of the pyrolysis study in practice – research of the distribution mechanism of heavy metals, alkaline earth and alkaline metals and non-metals, thermal processes. Knowledge of these mechanisms would facilitate application of pyrolysis products in other fields by chemical composition. Based on this work, it would be possible to predict the parts of distribution of elements in pyrolysis products applying similar thermochemical degradation and sewage sludge from other wastewater treatment plants. Administration of wastewater treatment plant, being aware of the initial concentrations of chemicals, i.e. elements of sewage sludge, could predict what percentage of them will remain in the solid fraction. After quantifying the results of this study and the data of other authors, the possible error of such a forecast would be $\pm 5\%$. This would save a significant portion of the company's finances because there would be no need to perform the initial analyses.

Practical application of the second part of the thesis, when it comes to use of sewage sludge char obtained for fertilizing energy plants (at the fertilization intensity 25-200 t/ha), would contribute significantly to the development of renewable energy, i.e. increase and use of biomass quantities.

- Based on the results of the studies carried out, the main distribution mechanisms of heavy metals, alkaline earth and alkaline metals and non-metals in the parts of the hemp when using sewage sludge char for fertilization would be determined. Precise knowledge of the possibilities of element absorption and the quantities accumulated would ensure a more targeted further use of energy grasses, whereas immobilisation of the by-products generated would reduce environmental pollution.
- Use of sewage sludge char for rehabilitating degraded soils and quarries that are no longer used. Sewage sludge char would help improve a quality of soil of these areas and energy cultures cultivated would increase a percentage of renewable energy in the total balance of energy use.
- LAND 20-2005, a document regulating the use of sewage sludge, is the only document currently available in Lithuania. Based on the obtained results of the study, as the initial source of studies, and after performing additional study it would be possible to prepare a normative document for the use of sewage sludge char for fertilization of energy cultures or for rehabilitating quarries that are no

longer used. Taking into account the experience of other European countries, a document that allows using sewage sludge char as the main component or as one of components for the purpose of increasing a biomass content of energy plants would be prepared.

CONCLUSIONS

1. The results of Šilutė city sewage sludge pyrolysis studies at 850° C can be summarized as follows:
 - ✓ Sludge pyrolysis carbon forms a major part of final pyrolysis products. 42 % pyrolysis carbon remain in the total mass balance. Liquid products account for 31 %, of which 12 % are resins and 18 % are condensates. Calculations showed that gas yield of the initial quantity of sewage sludge amounts to 28 %. The initial volume of sewage sludge is reduced by 2.4 times.
 - ✓ After the pyrolysis process, most of the elements and heavy metals remain in the solid fraction: heavy metals range from 40 % to 95 %, alkaline earth metals and alkaline metals from 64 % to 98 %, and balance of non-metals and other metals is more than 99 %, sulphur content drops significantly, 6 % of the initial quantity of sewage sludge remain. The study found that high temperature pyrolysis had the greatest impact on the transformation of heavy metals Cd, Co, Cr, Cu and Zn from sewage sludge to synthetic pyrolysis gas. Cd content was found to be the highest in the gas – 68 %. Co and Cr content in the gas was 35 % and 27 % respectively. Relatively low content of Cu and Zn (~ 10 %) in the gas was found due to high melting and boiling temperatures of these metals.
2. The following findings are provided to summarize the main results of the analysis of laboratory use of sludge carbon and sewage sludge for the yield of hemp (applying 25-200 t/ha):

The distribution of elements of selected groups in parts of hemp was found to be uneven:

 - ✓ Accumulation of Co, Cr, Cu and Zn in all parts of hemp decreases when quantities of sewage sludge and sludge carbon are increased. Concentrations of Ni significantly increase in the roots and stems when sewage sludge is used for fertilization. Accumulation of Ti and Fe in the roots decreases, and increases in the stems and leaves when quantities of sewage sludge and sludge carbon are increased. Accumulation of Mn increases in all parts of hemp only when quantities of sewage sludge are increased.
 - ✓ Accumulation of alkaline earth metals and alkaline metals in the parts of hemp increases when fertilization intensity is increased. A significant increase in the accumulation of Ba, Ca, K and Mg was observed when fertilization with both sewage sludge and sewage sludge carbon was intensified. Na was found to be exception. Its concentration in all parts of hemp decreases when fertilization with both sewage sludge and sewage sludge carbon is increased.

3. Compared to non-fertilized soil, biomass yield was only higher at 25 t/ha sewage sludge fertilization rate, while all other more intensive fertilization options had a negative impact on biomass growth. It can be said that fertilization with sewage sludge and fertilization with sewage sludge char, which is higher than 25 t/ha, is completely useless and unnecessary for the cultivation of hemp. Therefore, it is expedient to continue studies using sludge rates of less than 25 t/ha for fertilization, and to saturate sewage sludge char with additional macronutrients.

PUBLICATIONS RELATED TO THE DISSERTATION

Articles in journals from Thomson Reuters “Web of Knowledge” list

1. Praspaliauskas M., Pedišius N. A review of sludge characteristics in Lithuania's wastewater treatment plants and perspectives of its usage in thermal processes (<http://dx.doi.org/10.1016/j.rser.2016.09.041>) // Renewable and sustainable energy reviews. ISSN 1364-0321. Vol. 67. 2017. p. 899–907.
2. Praspaliauskas M., Pedisius N., Striugas N. Elemental migration and transformation from sewage sludge to residual products during the pyrolysis process (DOI: 10.1021/acs.energyfuels.8b00196) // Energy and Fuels, 2018, 32 (4), pp 5199–5208.

Publications at the international conferences

1. Praspaliauskas M., Pedišius N., Valantinavičius M. Perspectives of sewage sludge usage for energy production in Lithuania // Proceedings of the 7th Baltic heat transfer conference. ISBN 978-9949-23-817-0. Tallinn, Estonia August 24-26, 2015. p. 273-278.
2. Praspaliauskas M. Possibilities of anaerobic digested sewage sludge thermal utilization in Lithuania // 13th Annual international conference of young scientists on energy issues (CYSENI 2016), Kaunas, Lithuania, May 26–27, 2016. Kaunas: LEI, 2016. ISSN 1822-7554. p. 107-113.
3. Praspaliauskas M., Striūgas N. Heavy metal distribution in residual pyrolysis products of anaerobically digested sewage sludge // The 14th International Conference of Young Scientists on energy Issues (CYSENI 2017), Kaunas, Lithuania, May 25-26, 2017. Kaunas: LEI, 2017, ISSN 1822-7554. p. 51-58.
4. Praspaliauskas M., Žaltauskaitė J. Hemp ability accumulate heavy metals from high level fertilized soil of sewage sludge and sewage sludge char // The 15th International Conference of Young Scientists on Energy Issues (CYSENI 2018) Kaunas, Lithuania, May 23-25, 2018. Kaunas:LEI, 2018, ISSN 1822-7554. p. 48-54.
5. J. Žaltauskaite, M. Praspaliauskas, N. Striugas. Cannabis sativa as a tool to assess sewage sludge and sewage sludge char suitability for soil fertilization // 6th International Conference on Sustainable Solid Waste Management, Naxos Island, Greece, 13–16 June 2018.

Publications at the national conferences

1. Praspaliauskas M., Pedišius N. Nuotekų dumblo Lietuvos vandenvals sistemose savybių tyrimas // Šilumos energetika ir technologijos-2015: konferencijos pranešimų medžiaga, Kauno technologijos universitetas, 2015 sausio 29-30 Kaunas. LEI. 2015. ISSN 2335-2485. p. 9-26.

Reports in the international conferences

1. M. Praspaliauskas, N. Pedišius, Chemical analysis of sewage sludge characteristics in Lithuania's wastewater treatment plants, ISGC 2015 3rd International Symposium on Green Chemistry, La Rochelle, France, May 3-7, 2015.
2. Praspaliauskas M., Pedišius N., Valantinavičius M. Perspectives of sewage sludge usage for energy production in Lithuania // Proceedings of the 7th Baltic heat transfer conference. ISBN 978-9949-23-817-0. Tallinn, Estonia August 24-26, 2015. p. 273-278.
3. Praspaliauskas M. Possibilities of anaerobic digested sewage sludge thermal utilization in Lithuania // 13th Annual international conference of young scientists on energy issues (CYSENI 2016), Kaunas, Lithuania, May 26–27, 2016. Kaunas: LEI, 2016. ISSN 1822-7554. p. 107-113.
4. Praspaliauskas M., Striūgas N. Heavy metal distribution in residual pyrolysis products of anaerobically digested sewage sludge // The 14th International Conference of Young Scientists on energy Issues (CYSENI 2017), Kaunas, Lithuania, May 25-26, 2017. Kaunas: LEI, 2017, ISSN 1822-7554. p. 51-58.
5. Praspaliauskas M., Žaltauskaitė J. Hemp ability accumulate heavy metals from high level fertilized soil of sewage sludge and sewage sludge char // The 15th International Conference of Young Scientists on Energy Issues (CYSENI 2018) Kaunas, Lithuania, May 23-25, 2018. Kaunas:LEI, 2018, ISSN 1822-7554. p. 48-54.
6. J. Žaltauskaite, M. Praspaliauskas, N. Striugas. Cannabis sativa as a tool to assess sewage sludge and sewage sludge char suitability for soil fertilization // 6th International Conference on Sustainable Solid Waste Management, Naxos Island, Greece, 13–16 June 2018.

Reports in the national conferences

1. Praspaliauskas M., Pedišius N. Nuotekų dumblo Lietuvos vandenvals sistemose savybių tyrimas // Šilumos energetika ir technologijos-2015: konferencijos pranešimų medžiaga, Kauno technologijos universitetas, 2015 sausio 29-30 Kaunas. LEI. 2015. ISSN 2335-2485. p. 9-26.
2. Marius Praspaliauskas, Nerijus Striūgas, Nerijus Pedišius. Sunkiųjų metalų pasiskirstymas nuotekų dumblo pirolizės produktuose // Šilumos energetika ir technologijos-2017: Kauno technologijos universitetas, 2017 sausio 26-27 Kaunas.

Information about the Author of the Dissertation

Marius Praspaliauskas was born on 16 10 1987 in Nevarėnai Telšiai district, Lithuania. Contact information: tel. (+370) 37 4018951, e-mail: Marius.Praspaliauskas@lei.lt.

2007 – 2011 bachelor studies at Vytautas Magnus University, Department of Environmental and Ecology; Bachelor of Science in Environmental and Ecology.

2011 – 2013 master studies at Vytautas Magnus University, Department of Physics; Master of Science in Applied Physics.

2014 – 2018 doctoral studies at Lithuanian Energy Institute, Laboratory of heat equipment research and testing.

09.2014 – present Junior Research Associate at Lithuanian Energy Institute, Laboratory of heat equipment research and testing.

Padėka

Disertacijos darbo autorius dėkoja moksliniam vadovui dr. Nerijui Striūgui ir Lietuvos energetikos instituto, Šiluminių įrengimų tyrimo ir bandymų laboratorijos vadovui dr. Nerijui Pedišiui ir visiems laboratorijos kolegoms už naudingus patarimus ir paramą, disertacijos rengimo metu.

REZIUOMĖ

Didėjantis gyventojų skaičius, ypač miestuose, lemia vis didesnę susidarančių buitinių nuotekų kieki, kurios yra sukonzentruojamos vienoje vietoje. Dėl šios priežasties po nuotekų valymo ženkliai išauga susidarančio nuotekų dumblo kiekiai. Pastaruoju metu ši problema tampa vis aktualesnė ir vadinama “ateities atliekų problema“. Efektyvus nuotekų dumblo panaudojimas yra pagrindinis prioritetas tvarkant susidarančius nuotekų dumblo kiekius. Valstybės narės turėtų skatinti produktų perdirbimą, naudojimą vadovaudamosi atliekų hierarchija “sumažinti, pakartotinai panaudoti, perdirbti“ ir siekdamas kurti atliekas perdirbančią visuomenę ir, jei tik įmanoma, neturėtų skatinti atliekų, kurias galima perdirbti, šalinti sąvartynuose bei jas deginti. Remiantis Europos Sąjungos reglamentais, matyti, kad atliekų tvarkymo metodai susiję su saugojimu šiuo metu yra keičiami į metodus, kurie reglamentuoja tokių atliekų saugų perdirbimą, antrinę panaudojimą ir produktų kūrimą. Tokiu būdu skatinamas ir nuotekų dumblo darnus panaudojimas, kai gaunami vertingi produktai, kurie toliau duoda naudą žemės ūkyje, įvairiose pramonės srityse, šilumos ir energijos gamybai.

Tyrimo metu apžvelgti kitų mokslinių tyrimų rezultatai rodo, kad nuotekų dumblo apdorojimo ir panaudojimo būdų yra gana nemažai, tačiau dėl padidintų sunkiųjų metalų koncentracijų, kurios riboja tokių technologijų plėtrą nėra nuosekliai ištirtos. Viena tokių, sunkiųjų metalų ir kitų elementų migracija nuotekų dumblą panaudojant pakopiniuose procesuose, kai po terminio apdorojimo likusi kietoji frakcija (dumblo anglis) panaudojama energetinių augalų biomasės prieaugiui didinti. Dažniausiai mokslinėje literatūroje elementų išgavimas nustatomas nuotekų dumblo anglyje. Šiame darbe pateikiama platesnė elementų pasiskirstymo analizė. Nagrinėjamas išgavimas ne tik nuotekų dumblo anglyje, bet ir kituose pirolizės produktuose kaip dervos ir kondensatas. Įvertinus paklaidas taip pat buvo apskaičiuotas elementų išgavimas su išsiskiriančiomis dujomis.

Darbo tikslas

Nustatyti anaerobiškai pūdyto nuotekų dumblo terminio skaidymo inertinėje aplinkoje (pirolizė) sunkiųjų metalų, šarminių žemių, šarminių metalų bei nemetalų susidariusiuose produktuose pasiskirstymą ir įvertinti nuotekų dumblo pirolizės anglies įtaką kauptis cheminiams elementams atskirose pluoštinės kanapės dalyse, t.y. šaknyse, stiebuose, lapuose.

Darbo uždaviniai

Igyvendinant mokslinio darbo tikslą, buvo išskelti šie pagrindiniai uždaviniai:

1. Nustatyti pirolizės proceso metu susidariusių nuotekų dumblo produktų (anglies, dervų, kondensato ir dujų) išeią.
2. Atlikti susidariusių pirolizės produktų cheminę analizę, nustatant sunkiųjų metalų, šarminių žemių ir šarminių metalų bei nemetalų pasiskirstymą pirolizės produktuose.
3. Įvertinti pirolizės proceso metu susidariusios nuotekų dumblo anglies (produktas) panaudojimą tręšimui, laboratorinėmis sąlygomis auginant pluoštinę kanapę (*Cannabis sativa L.*).
4. Įvertinti nuotekų dumblo anglies įtaką pluoštinės kanapės biomasei priaugti bei sunkiųjų metalų, šarminių žemių, šarminių metalų ir nemetalų pasisavinimą skirtingose augalo dalyse (šaknys, stiebas, lapai).

Darbo aktualumas

Vandenvalos sistemose susidarančio dumblo kiekis jau dabar kelia rimtų problemų, susijusių su jo saugojimu ir panaudojimu. Miesto nuotekų valymo direktyvos 91/271/EEB 14 straipsnyje nurodoma, kad „dumblas, susidaręs valant nutekamuosius vandenius, jei tik įmanoma, turi būti panaudojamas. Jo šalinimo būdai privalo iki minimumo sumažinti aplinkai daromą neigiamą poveikį“. Todėl pirmumas teikiamas nuotekų dumblo antriniam panaudojimui, o ne išvežimui į sąvartynus ar saugojimo aikšteles. Mokslinių tyrimų rezultatai rodo, kad pirolizė yra pagrindinė alternatyva nuotekų dumblo antriniam panaudojimui. Pirolizės proceso metu ženkliai sumažinamas pirminės medžiagos tūris bei generuojami vertingi šalutiniai produktai, kurie yra chemiškai stabilūs ir koncentruoti. Dėl šios priežasties po pirolizės gaunamų antrinių medžiagų tolimesnis panaudojimas žemės ūkyje, įvairių produktų gamyboje yra labiau priimtinas negu taikant kitus technologinius procesus. Žinant elementų pasiskirstymo dėsninumus pirolizės produktuose, galimas tolesnis jų panaudojimas energetiniams augalams auginti. Tai būtų aplinkosaugos požiūriu draugiškas technologinis procesas, kai vieno proceso metu gautas antrinis produktas būtų panaudotas kito proceso metu gaunant naują vertingą produktą. Taikant šią technologiją, į aplinką patektų mažiau pavojingų medžiagų.

Mokslinis naujumas

Taikant aukštos temperatūros pirolizę, nustatytas sunkiųjų metalų ir kitų cheminių elementų pasiskirstymas pirolizės proceso produktuose, taip pat nustatyti šių elementų kaupimosi dėsninumai skirtingose pluoštinės kanapės dalyse (šaknys, stiebas, lapai) tręšiant (skirtingu intensyvumu) ją nuotekų dumbliu ir nuotekų dumblo pirolizės anglimi.

Rezultatų praktinė reikšmė

Atlikus tyrimą įvertintas darnus nuotekų dumblo panaudojimo aspektas; pirolizė leidžia iki 2,5 karto sumažinti dumblo kiekius bei išgauti naudingus antrinius produktus, kurie, nors ir turėdami savyje taršiųjų medžiagų (sunkieji metalai), toliau gali būti naudojami kaip alternatyvi žaliava kitose srityse. Taip pat įvertintos laboratorinėmis sąlygomis išaugintos pluoštinės kanapės (*Cannabis sativa L.*) savybės pasisavinti sunkiuosius metalus iš dirvožemio, tręšto nuotekų dumblo ir jo pirolizės produktais.

Ginamieji disertacijos teiginiai

1. Džiovinto ir anaerobiškai pūdyto nuotekų dumblo tūris po terminio apdorojimo sumažėja apie 2 kartus, o likutinę kietosios frakcijos dalį gautuose produktuose sudaro nuotekų dumblo anglis;
2. Didžioji dalis sunkiųjų metalų, šarminių žemių ir šarminių metalų, kitų metalų ir nemetalų po pirolizės proceso lieka susidariusioje nuotekų dumblo pirolizės anglyje;
3. Intensyvinant tręšimą tiek nuotekų dumblo, tiek nuotekų dumblo pirolizės anglimi, pluoštinių kanapių biomasės prieaugis didėja tik iki tam tikros ribos, ir esant optimaliam tręšimui pasiekiamas didžiausias biomasės prieaugis, po to biomasės prieaugis pradeda mažėti;
4. Intensyvinant tręšimą nuotekų dumblo anglimi, pluoštinės kanapės dalyse mažėja sunkiųjų metalų kaupimasis, o šarminių žemių ir šarminių metalų kaupimasis didėja.

Atlikus pirolizės tyrimus nustatyta, kad didžiąją dalį galutinių produktų sudaro dumblo anglis. Bendrame masės balanse jos lieka 41,8 %. Skystieji produktai sudaro 30,7 %, iš kurių 12,23 % yra dervos ir 18,47 % kondensatas. Skaičiavimais nustatyta, kad dujų išėiga nuo pradinio nuotekų dumblo kiekio sudaro 27,5 %. Po pirolizės proceso didžioji dalis elementų ir sunkiųjų metalų lieka kietojoje frakcijoje, tačiau bendras balansas, lyginant su nuotekų dumblo, išlieka nepakitęs: sunkieji metalai sudaro nuo 39,51 % iki 95,29 %, šarminiai žemių ir šarminiai metalai nuo 63,93 % iki 98,03 %, o nemetalų ir kitų metalų balansas didesnis nei 99 %, sieros kiekis ženkliai sumažėja, lieka 5,75 % nuo pradinio kiekio buvusio nuotekų dumble. Tyrimo metu nustatyta, kad aukštatemperatūre pirolizė didžiausią įtaką darė sunkiųjų metalų Cd, Co, Cr, Cu ir Zn transformacijai iš nuotekų dumblo į sintetines pirolizės dujas. Kadmio kiekis dujose nustatytas didžiausias ir siekė 68,17 %. Tokį didelį Cd kiekį dujose lemia žema virimo temperatūra 767 °C. Co ir Cr kiekiai dujose sudarė atitinkamai po 34,51 % ir 27,22 %. Šie metalai priskiriami pusiau lakiųjų sunkiųjų metalų kategorijai, kas ir sukelia tokį efektą. Santykinai nedideli Cu ir Zn kiekiai ~ 10 %

dujose nustatyti dėl aukštų šių metalų lydymosi ir virimo temperatūrų, tačiau tikėtina, kad dėl reakcijų su chloru šių metalų yra susidarantiuose dujose.

Lyginant su kontroliniu variantu biomasės priaugis buvo didesnis tik prie 25 t/ha nuotekų dumblo normos, o visi kiti tręšimai davė neigiamą poveikį biomasės priaugiui. Galima teigti, kad didesnis nei 25 t/ha tręšimas nuotekų dumblo ir tręšimas nuotekų dumblo anglimi yra visiškai nenaudingas ir nereikalingas. Šiuo atveju atsiranda būtinybė atlikti tolimesnius tyrimus tręšimui naudojant mažesnes nei 25 t/ha nuotekų dumblo normas, o nuotekų dumblo anglį prisotinti papildomais makroelementais, tokiais kaip kalis. Co, Cr, Cu ir Zn kaupimasis visose kanapės dalyse mažėja didinant tiek nuotekų dumblo, tiek dumblo anglies kiekius. Ni kaupimuisi ženkliai didėjo šaknyse ir stiebuose tręšiant nuotekų dumblo. Ti ir Fe kaupimasis šaknyse mažėja, o stiebuose ir lapuose didėja didinant nuotekų dumblo ir dumblo anglies kiekius. Didinant nuotekų dumblo kiekius Mn kaupimasis didėja visose kanapės dalyse, o didinant dumblo anglies kiekius Mn kaupimasis nesikeičia. Šarminių žemių ir šarminių metalų kaupimasis kanapės dalyse didėjant tręšimo intensyvumui ženkliai didėja. Nustatytas ženklus Ba, Ca, K ir Mg kaupimosi faktoriaus didėjimas intensyvinant tręšimą nuotekų dumblo ir dumblo anglimi. Išimtis nustatyta Na, kurio koncentracija didinant tręšimą nuotekų dumblo ir dumblo anglimi visose kanapės dalyse mažėja.

IŠVADOS

1. Atlikus Šilutės miesto nuotekų dumblo pirolizės tyrimus esant 850 °C, rezultatus galima apibendrinti šiomis išvadomis:
 - ✓ Didžiąją galutinių pirolizės produktų dalį sudaro dumblo pirolizės anglis, kurios bendrame masės balanse lieka 42 %. Skystieji produktai sudaro 31 %, iš kurių 12 % yra dervos ir 18 % – kondensatas. Skaičiavimais nustatyta, kad dujų išėiga nuo pradinio nuotekų dumblo kiekio sudaro 28 %. Pradinis nuotekų dumblo tūris sumažinamas 2,4 karto.
 - ✓ Po pirolizės proceso didžioji dalis elementų ir sunkiųjų metalų lieka kietojoje frakcijoje: sunkieji metalai sudaro nuo 40 % iki 95 %, šarminiai žemių ir šarminiai metalai nuo 64 % iki 98 %, o nemetalų ir kitų metalų balansas didesnis nei 99 %, sieros kiekis gerokai sumažėja, lieka 6 % nuo pradinio nuotekų dumblo kiekio. Tyrimo metu nustatyta, kad aukštos temperatūros pirolizė didžiausią įtaką darė sunkiųjų metalų Cd, Co, Cr, Cu ir Zn transformacijai iš nuotekų dumblo į sintetines pirolizės dujas. Cd kiekis dujose nustatytas didžiausias ir siekė 68 %. Co ir Cr kiekiai dujose sudarė atitinkamai 35 % ir 27 %. Santykinai nedideli Cu ir Zn kiekiai (~ 10 %) dujose nustatyti dėl aukštų šių metalų lydymosi ir virimo temperatūrų.
2. Ištyrus laboratorinį dumblo anglies ir nuotekų dumblo panaudojimą pluoštinės kanapės biomasės prieaugiui (taikant 25–200 t/ha kiekius), gautus pagrindinius rezultatus galima apibendrinti šiomis išvadomis:

Pasirinktų grupių elementų pasiskirstymas pluoštinės kanapės augalo dalyse nustatytas nevienodas:

 - ✓ Co, Cr, Cu ir Zn kaupimasis visose kanapės dalyse mažėja, didinant tiek nuotekų dumblo, tiek dumblo anglies kiekius. Ni koncentracijos gerokai didėja šaknyse ir stiebuose tręšiant nuotekų dumblu. Ti ir Fe kaupimasis šaknyse mažėja, o stiebuose ir lapuose didėja, didinant tiek nuotekų dumblo, tiek ir dumblo anglies kiekius. Mn kaupimasis didėja visose kanapės dalyse tik didinant nuotekų dumblo kiekius.
 - ✓ Šarminių žemių ir šarminių metalų kaupimasis kanapės dalyse didėja didinant tręšimo intensyvumą. Nustatytas žymus Ba, Ca, K ir Mg kaupimosi didėjimas intensyvinant tręšimą tiek nuotekų dumblu, tiek nuotekų dumblo anglimi. Išimtis yra Na, kurio koncentracija visose kanapės dalyse mažėja, didinant tręšimą tiek nuotekų dumblu, tiek ir dumblo anglimi.
3. Lyginant su netręštu dirvožemiu, biomasės prieaugis buvo didesnis tik prie 25 t/ha nuotekų dumblo tręšimo normos, o visi kiti intensyvesni tręšimo variantai davė neigiamą poveikį biomasės prieaugiui. Galima teigti, kad didesnis nei 25 t/ha tręšimas nuotekų dumblu ir tręšimas nuotekų dumblo anglimi yra visiškai nenaudingas ir nereikalingas auginant pluoštinę kanapę.

Todėl yra tikslinga tęsti tyrimus, tręšimui naudojant mažesnes nei 25 t/ha nuotekų dumblo normas, o nuotekų dumblo anglį prisotinti papildomais makroelementais.

UDK 628.336,53+628.381+633.522](043.3)

SL344. 2019-03-22, 3 leidyb. apsk. l. Tiražas 50 egz.

Išleido Kauno technologijos universitetas, K. Donelaičio g. 73, 44249 Kaunas
Spausdino leidyklos „Technologija“ spaustuvė, Studentų g. 54, 51424 Kaunas