

The research of single point incremental forming process for composite mould production

M. Rimašauskas*, **K. Juzėnas****, **R. Rimašauskienė*****, **E. Pupelis******

*Kaunas University of Technology, Kęstučio 27, 44312 Kaunas, Lithuania, E-mail: marius.rimasauskas@ktu.lt

**Kaunas University of Technology, Kęstučio 27, 44312 Kaunas, Lithuania, E-mail: kazimieras.juzenas@ktu.lt

***Kaunas University of Technology, Kęstučio 27, 44312 Kaunas, Lithuania, E-mail: ruta.rimasauskiene@ktu.lt

****Kaunas University of Technology, Kęstučio 27, 44312 Kaunas, Lithuania, E-mail: edmundas.pupelis@ktu.lt

crossref <http://dx.doi.org/10.5755/j01.mech.20.4.7045>

1. Introduction

Today, companies, aiming to survive the intense competition in manufacturing sector, must constantly improve their technological processes. On the other hand, constantly changing and growing customer requirements make companies seek not only for high quality and effective, but especially for flexible technologies. The increasing demand for large scale customised composites is driving a trend toward low cost, lighter – weight, durable composite tooling development and away from traditional tooling. Sheet aluminium blanks can be used for production of moulds for composite structure manufacturing and drastically decrease manufacturing cost and time of tooling. [1]. Although sheet metal may be formed in various ways, but not all methods are suitable for small batch production especially for production of moulds for composites. Traditional technologies, such as, for example, stamping or deep drawing requires large investment and are not flexible. In this case, each production of mould requires special technological equipment, which extremely increases manufacturing time and cost. New sheet metal forming technologies enable manufacturing of one piece products and prototypes of various complex shapes, using only simple and flexible tooling. These technologies are called die-less forming. Incremental sheet metal forming (ISMF) is effective for prototyping and small batch production. Moreover, it is highly flexible and carries only low set-up costs [2, 3]. Simple ISMF application requires conventional CNC milling machine, relatively simple equipment and tools. In addition, researchers are constantly working on the improvement of this technology, aiming to make it even more applicable [1-6]. Although scientific magazines publish significant amount of publications in this regard, this technology is not completely researched yet, because it depends on variety of non-constant parameters. Now, it is well known that the efficiency of ISMF and quality of prototype depends on parameters of technological process and properties of material processed [4].

Some researchers concentrate on optimisation of a toolpath, maintaining that it helps to improve quality of products while reducing manufacturing costs. The influence of a toolpath in traditional milling technology is well known and has been discussed in various scientific publications. However, currently the researchers insist that a toolpath is one of the most important factors influencing the quality of the process in ISMF technology too [5, 6]. On the other hand, this technology is further developed,

and new factors influencing the quality and the efficiency of the process are added. Robotic ISMF is one of the alternatives for manufacturing sheet metal products of complex geometrical shapes. In this case, standard CNC processing centre is replaced by one or several robots that make the technology even more flexible [7]. Although originally this technology was intended for soft metals, currently there are see publications that discuss its efficiency in processing hard-to-form titanium sheets. In this case, hard-to-form materials are processed applying additional heating of a tool or sheet metal [8]. In this case, there are two additional parameters: temperature and lubrication between a tool and material formed. Some additional measures are applied aiming to increase the efficiency of the process with soft sheet metal too, e.g. variously shaped cuts [9]. The formability of sheet metal, especially of single point incremental forming (SPIF), extremely depends on the rigidity of sheet metal formed [10].

Surface parameters of a product formed, namely roughness, are important indicators of quality, especially for mould production. Since ISMF is a contact processing method, roughness of the surface processed depends on the process, the tool, the shape of the prototype, and the parameters of the material. Roughness forecast and analytical thinking become extremely important aiming to manufacture products with desired quality of their surface. The analytical roughness assessment model designed allows forecasting roughness already in early manufacturing stages [11]. However, fracture forecast is important too, since closed contour of the product is not always performed smoothly. Fractures appear due to extreme tension of sheet metal and it may be prevented only by process simulation in early manufacturing stage and the selection of suitable technological parameters [12].

Although ISMF is not the one only alternative technology which can be used for composite mould production (fast, cheap and flexible tooling is also called rapid tooling presented in various papers [13-15]), this technology provides many opportunities for composites tooling with low investments.

This article analyses material formation features in relation to changing geometrical shape of the part formed. Main task of this research paper is to find optimal technological regimes of single point incremental process for composite mould production. On other hand at least few materials also need to be tested because of their different formability properties.

2. Design and building of the SPIF tooling

Six different types of the ISMF technology may be used depending on the use of blank fixing, supports and the number of tools used for the process. The simplest process when sheet metal forming method requires only one tool and does not require any support called SPIF. Although this method is the simplest, it ensures the high enough quality and it is very flexible process, enabling production of different shape moulds. The frame (Fig. 1) of technological equipment was designed and used for experimental tests. Such fixing allows local deformation of the processed sheet and enables keeping it in initial position during the entire process. Working area of the designed equipment is 170x170 mm. Maximum height of the formed prototype is 100 mm.

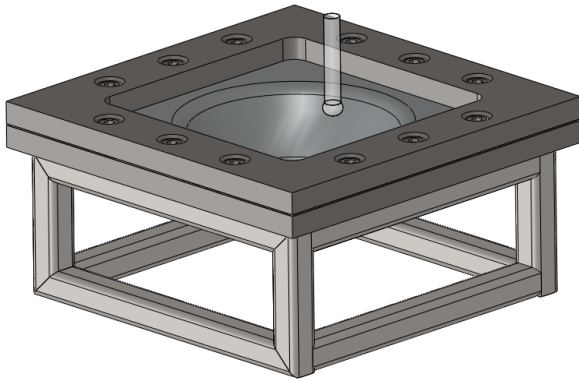

Fig. 1 SPIF technological equipment

A tool used for the formation of a sheet metal is fixed at a spindle of CNC milling machine. Tools intended to process different surfaces differ by their shape and by the size of their working part. Fig. 2 shows tools of three types. A sphere ended tool is typically used for the manufacturing of different shape elements. Flat ended tool is used in processing of flat surfaces and forming of angles. Small diameter sphere ended tools, are designed for the formation of small precise elements.



Fig. 2 Main shapes of tools

The diameter of a tool has a great influence on formation process. Tools with smaller radius of a working part possess better forming characteristics. Using smaller tools, heat, emitted in result of friction, is highly localized, thus material becomes more tensile and formable. However, radius of a tool cannot be reduced to unlimited extent due to the strength and resistance to bending fatigue of tools material. On the other hand, smaller tool means greater consumption of manufacturing time.

During the manufacturing process, a tool can rotate in the direction of movement or counter it. Direction of rotation influences the quality of the surface. In case of

counter-movement rotation, the surface experiences additional deformations. Metal heats up at greater extent, its structure changes, and the surface becomes rough. Therefore the movement-wise direction of rotation is used more often. In this case, it is attempted to match rotation and sliding speeds of a tool. By this way, the tool is working with the rolling friction, heat emission is reduced, and the quality of processed part is improved. On the other hand, a tool may not be brought into the forced rotation at all. In this case, a tool is fixed in a spindle and left for free movement. Here, rotation of tool appears in result of friction forces acting between the tool and the part processed.

3. Methodology

Since literature lack for the information on the selection of work regimes, this work is focused on the analysis of practical applications of SPIF for sheet metal mould production. Technological regimes were set experimentally. The technological process involves sheet metal forming only, thus the processing regimes might be noticeably higher than in metal cutting procedures. Movement and rotation speed ratio is considered optimal when it provokes the rolling friction. But it should be taken into account, that rolling friction is almost impossible with a sphere ended tool, due to tool spherical surface. On the other hand, there is an opinion, that forming improves when lower regimes or increased temperatures of a tool and material processed are used [12]. Some other parameters (e.g. tollpath) that might influence the quality of the part processed were changed during experiments. It should be noticed, that experiment was prepared with a help of specific CAM systems that allow generating various toolpaths. But it should be stated that does not exist the optimal toolpath for all prototypes thus changes of geometrical shapes might require different toolpaths. Moreover the toolpath influences not only the efficiency of the process, but also the quality of the surface of the part processed. The spiral toolpath was used in all experiments because it was considered as the best for selected shapes of moulds prototypes.

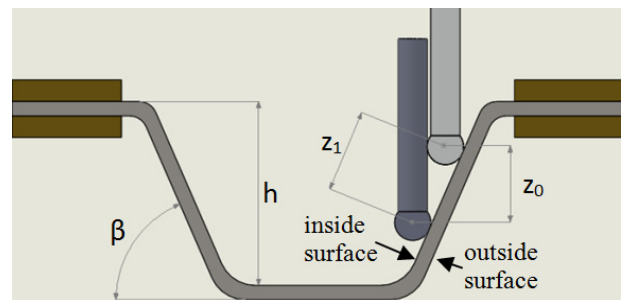

Fig. 3 The most important parameters of the part processed

One of the most important parameters of a mould – the wall thickness depends on the thickness of material processed, tool forming angle β , and forming height h and other (Fig. 3). It is known that forming process becomes more complicated when angle β gets closer to 90° . In this case, walls become thinner and may fracture. Thus, an equation for forecasting shear formed wall thickness in relation to forming angle can be used [16]:

$$t_f = t_0 \sin(90 - \beta), \quad (1)$$

where t_0 is thickness of sheet metal before forming, mm; β is forming angle, degrees; t_f is forecasted thickness of sheet metal after the operation, mm.

The influence of tool movement step on formability of sheet metal is still under the discussion. The main assumption is that the shorter the step the greater the formability, and vice versa [17].

Roughness is another important indicator of surface quality, which is also very significant for composite mould. Tool movement step in direction of z (vertical) axis is one of the main factors influencing roughness of the surface. Surface roughness depends on a shape and on a size of a tool also. It is important to mention that smaller diameter spherical tools produce elements of higher quality surface, however highly increases manufacturing costs and time. Then the vertical tool movement step z_0 is selected, z_1 may be calculated as follows:

$$z_1 = z_0 / \sin \beta, \quad (2)$$

where β is forming angle, degrees; z_0 is tool movement step in direction of z axis, mm; z_1 – tool movement step in relation to forming angle, mm. Then forecasted surface roughness may be calculated as follows [9, 15].

$$Rz = \frac{125 z_1^2}{r}, \quad (3)$$

where Rz is forecasted roughness of the part processed, μm ; r is radius of the working part of a tool, mm. Typically, this formula guarantee only 10% error between forecasted and actual roughness. It has also been observed that surface roughness is higher in case with non – rotating tools [18]. The surface roughness can be reduced decreasing the relative motion between a tool and a work piece. Actually it is important to determine roughness of outside and inside surfaces of the mould wall, once each surface could be used for production of composite structure. Here surface which has contact with tool is called the inside surface.

The hardness of mould surface is another important parameter which has crucial importance on composite mould quality. By using SPIF technology materials are deformed plastically and their surfaces are hardened. During the experiments aluminium alloys were used for mould production and changes of materials mechanical properties have been analysed aiming to improve mechanical characteristics of moulds.

4. Experimental tests

Experiments were performed on CNC machine DMU 35M. Processing programs were developed with *MasterCam 9* software. Equipment of the experiments is shown in Fig. 4. During experimental analysis two different materials were used. For the first experimental part aluminium EN AW5754 and EN AW1050 DDQ for the second part of analysis was used. Two different materials were chosen because of their different formability. Later stepover was changed and formability of the part was checked to find the highest formability angle. First part of the experiments was performed using the fixed work regimes. Spindle rotation direction matched the direction of

movement.

Spindle rotation speed – 400 rpm, feed rate – 400 mm/min and plunge rate – 300 mm/min. Tool movement in direction z axis was recalculated in accordance to the displacement in direction of x – y axis (stepover). The stepover was 0.8 mm during experiments of the first type. Later stepover was reduced and formability checked.



Fig. 4 Experimental setup

During the first part of the experiments with AW5754 aluminium, parts of similar circular shape were formed. The depth of the prototype formed $h = 40$ mm, remained constant during all the experiments. Forming angle β varied from 42° to 85° . Also, it should be noticed that maximum dimensions of formable area in x and y axis direction remained the same – 170×170 mm. However, dimensions of the part selected in x and y axis were 100×100 mm. The support sheet that restricts forming of sheet metal was used too. The first experiment was performed on aluminium AW5754 material, which chemical composition is delivered in Table 1.

Table 1

Chemical composition

Quantity, %	AW 5754	AW 1050 DDQ
Mn	0.5	0.01
Mg	2.6-3.6	0.05
Fe	0.4	0.4
Si	0.4	0.25
Al	Rest	99.5
Zn	0.2	0.07
Cu	0.1	0.05
Others	0.15	0.03

Mechanical properties formed materials are presented in Table 2. Aluminium AW 5754 possesses good forming properties thus it is used for deep drawing and rolling. However, it should be highlighted, that single point incremental sheet forming can generates greater elongations than a deep drawing method.

Table 2

Mechanical properties

Mechanical properties	AW 5754 H111	AW 1050 DDQ H111
Proof stress 0.2%, MPa	80	20
Tensile strength, MPa	190-240	65-95
Elongation, %	12-18	22-35
Vickers hardness (HV)	55	20

Another material used in experiments was aluminium AW 1050 DDQ. This type of material is common to use in deep drawing technology because elongation can be until 35%.

Fig. 5 shows the dependence between forming depth and forming angle. As it was mentioned, forming depth was kept constant in all cases. The diagram shows that only two parts avoided fractures. Whereas, when forming angle exceeds 53°, forming depth dramatically decreases.

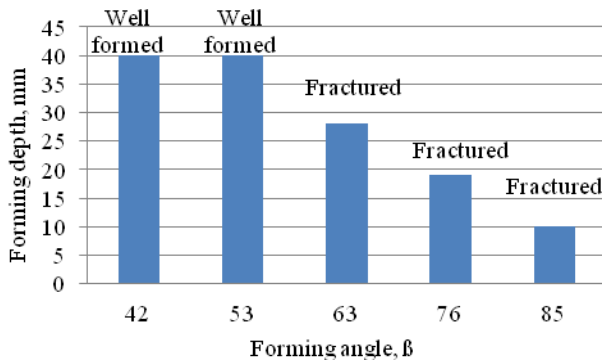

Fig. 5 The dependence of forming depth (till the fracture of specimen) on forming angle for AW5754

In all cases, fractures looked very similar. They are delivered in Fig. 6. However fractures' locations differed. When forming angle is at its maximum 85°, fractures appear in the corners. It should be mentioned, that the corners of the parts formed were rounded at a radius of $r = 20$ mm. Meanwhile, when the forming angle was 63°, the first fracture appeared on a straight formed surface. In this case, corners were formed smoothly, and only then the fracture appeared.

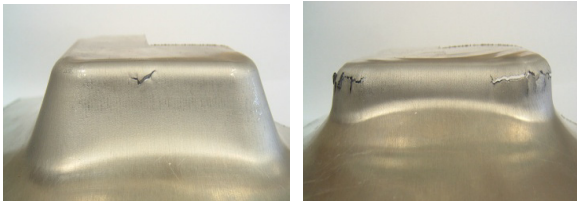

Fig. 6 Fractures of formed elements

Fig. 7 shows the distribution of sheet metal thickness, when forming angle is 42°. The diagram shows, that maximum reduction of thickness is up to 1.09 mm, and this thickness is enough aiming to ensure good mechanical properties of the part formed. The thickness was measured each 5 mm by microscope Nikon L-IM and professional microscope camera Pixelink PL-A662. Analytical calculation of sheet metal wall thickness Eq. (1) after the formation gives the forecasted 1.11 mm thickness.

Fig. 8 shows the distribution of sheet metal thickness, when the forming angle is 63°. Measurements were performed each 5 mm, as in the first case. It might be noticed, that in this case, sheet metal is elongated much more, and the thickness is only 0.65 mm in the thinnest place. This might be considered as marginal thickness, since it leads to fracture. Measurement of walls of the prototype with forming angle of 76° indicated 0.65 mm thickness in their thinnest place. Thus, it can be stated that maximum reduction of 1.5 mm thick aluminium alloy AW5754 sheet

is up to 0.65 mm for such SPIF process. Analytical calculation of wall thickness, when forming angle is 63°, gives the forecasted thickness of 0.68 mm.

The results show, that forecasted wall thickness is almost the same as obtained empirically, thus Eq. (1) can be used for early forecasting of product design and manufacturing stages.

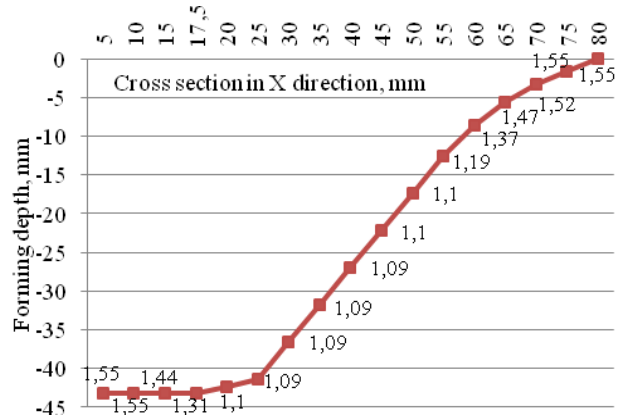

Fig. 7 The distribution of part wall thickness for material AW5754, forming angle 42°

Measurement of walls of the part without fractures, with the forming angle 76°, indicated the thickness of 0.42 mm. However, analytical calculations using the Eq. (1) forecast wall thickness of 0.36 mm. But it should be mentioned that Eq. (1) is dedicated for forecasting of wall thickness of shear formed parts. It should be mentioned that when the wall thickness of formed part is lower than 0.7 mm micro fractures can occur. These defects of structure can influence mechanical properties and quality of the mould and later – the quality of formed composite.

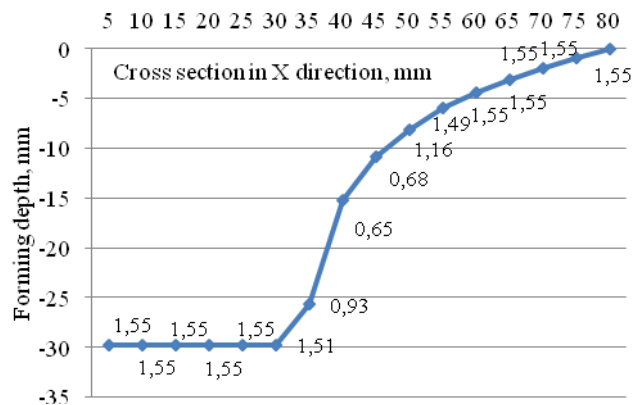

Fig. 8 The distribution of part wall thickness for material AW5754, forming angle 63°

Thus deep parts (depth is more than 50 mm) cannot be formed from aluminium AW5754 because of the risk of microcracking. Therefore another part of experiments was performed with aluminium AW1050. In this case better formability properties were found. In this case work regimes was constant: spindle rotation speed – 400 rpm, feed rate – 400 mm/min and plunge rate – 300 mm/min, stepover – 0.8 mm. Fig. 9 shows the dependence between forming depth and forming angle. However it was necessary to decrease work regimes then the macro fractures occurred. Further experiments showed that

forming angle of 75° can be obtained with stepover of 0.4 mm. Moreover, after these experiments it is possible to conclude that material AW1050 has significantly better formability characteristics in comparison with AW5754 and can be used for production of deeper moulds what do not care high mechanical loads.

SPIF is very efficient technology, in comparison with hard tooling manufacturing. For example to form part with angle 75° , and depth 93 mm takes 54 min. while with conventional mould making processes (only roughing) could take more than 2 hours.

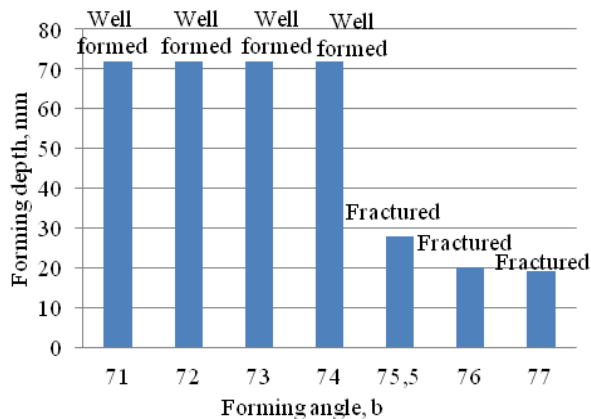

Fig. 9 The dependence of forming depth (till the fracture of specimen) on forming angle for AW1050

Plastic deformation of the metal allows producing complex moulds. Therefore aluminium alloy structure and mechanical properties are drastically changed too. It is known hardness of AL-Mg alloys increases by 20 – 30% after plastic deformation. However data in Fig. 10 shows that hardness of material AW5754 increase about 60 % after deformation. Change of AW1050 hardness is very similar. When thickness of mould is 0.7 mm hardness is higher by approximately 60%.

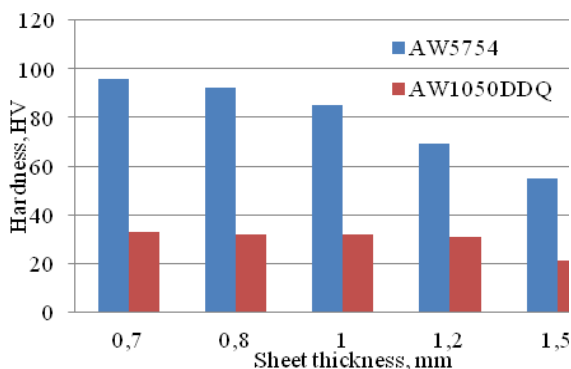

Fig. 10 Cross-section hardness of formed parts

Aiming to define the quality of the surface, surface waviness of the both sides of formed parts different forming angles was measured (Fig. 11). It was noticed, that waviness of the inside surface is lower in comparison with the outside surface. Moreover, if tool stepover distance decreases, waviness decreases too. It can be noticed that for forming angle of 76° waviness of the outside surface increases significantly. Such results have been obtained because two forming passes were used in this case. That helped to increase forming angle, but waviness increased

significantly too. Therefore applications of such multi pass method can be limited by requirements for the quality of moulds surfaces.

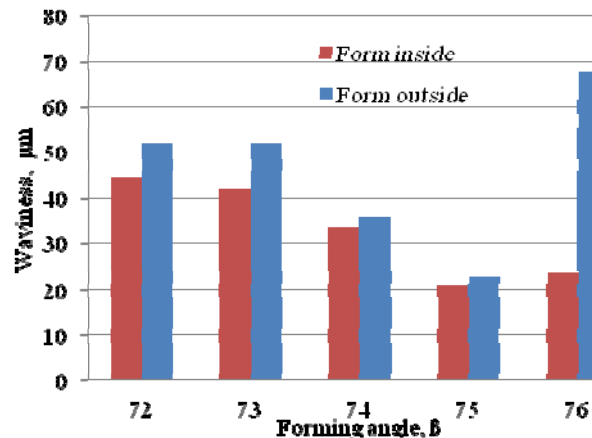

Fig. 11 Waviness of formed parts (AW1050)

5. Results and conclusions

The conclusions are mainly based on empirical data. The experiment was performed using aluminium alloys AW5754 and AW1050, thus other materials may condition different results. Conclusions of the experimental research might be useful for the development of new innovative products in the area of rapid prototyping, tooling and advanced fast production of customised composite structures. The research performed enables making the following conclusions:

1. The presented method could be used for rapid production of moulds for manufacturing of composite structure. This technology allows reducing of manufacturing time and manufacturing cost in comparison with conventional tools making technologies.

2. It was defined that formability of the moulds greatly depends on the forming angle and mechanical properties of formed material. For material AW5754, forming angle can be to 53° , but for material AW1050 forming angle can be to 75° then using one forming pass. The angle can be higher when two forming passes are used.

3. Analysis of waviness of formed surfaces showed that there is a possibility to produce moulds and prototypes of high surface quality. E.g. surface waviness R_t varies from 20 to 52 μm for AW1050 alloy in single pass mode of forming.

Acknowledgment

This research is funded by the European Social Fund under the project "In-Smart" (Agreement No VP1-3.1-ŠMM-10-V-02-012).

References

1. Fiorotto, M.; et al. 2010. Preliminary studies on single point incremental forming for composite materials, International Journal of Material Forming 3, 1: 951-954. <http://dx.doi.org/10.1007/s12289-010-0926-6>.
2. Luo, Y.; He, K.; Du, R. 2010. A new sheet metal forming system based on incremental punching, part 2:

- machine building and experimental results, *International Journal of Advanced Manufacturing Technology* 51: 493-506.
<http://dx.doi.org/10.1007/s00170-010-2635-1>.
3. **Emmens, W. C.; et al.** 2010. The technology of Incremental Sheet Forming-A brief review of the history, *Journal of Materials Processing Technology* 210: 981-997.
<http://dx.doi.org/10.1016/j.jmatprotec.2010.02.014>.
 4. **Giuseppina, A.; et al.** 2010. Prediction of incremental sheet forming process performance by using a neural network approach, *International Journal of Advanced Manufacturing Technology* 54: 921-930.
<http://dx.doi.org/10.1007/s00170-010-3011-x>.
 5. **Rauch, M.; et al.** 2009. Tool path programming optimization for incremental sheet forming applications, *Computer-Aided Design* 41: 877-885.
<http://dx.doi.org/10.1016/j.cad.2009.06.006>.
 4. **Li M.; et al.** 2011, Tool – path generation method for sheet metal incremental forming process, *Materials research innovations* 15: 278-282.
<http://dx.doi.org/10.1179/143307511x12858957674030>
 6. **Meier, H.; et al.** 2009. Increasing the part accuracy in dieless robot-based incremental sheet metal forming, *CIRP Annals – Manufacturing Technology* 58: 233-238.
<http://dx.doi.org/10.1016/j.cirp.2009.03.056>.
 7. **Fan G.; et al.** 2010. Electric hot incremental forming of Ti-6Al-4V titanium sheet, *International Journal of Advanced Manufacturing Technology* 49: 941-947.
<http://dx.doi.org/10.1007/s00170-009-2472-2>.
 8. **Allwood, M. J.; Braun, D.; Music, O.** 2010. The effect of partially cut-out blanks on geometric accuracy in incremental sheet forming, *Journal of Materials Processing Technology* 210: 1501-1510.
<http://dx.doi.org/10.1016/j.jmatprotec.2010.04.008>.
 9. **Hussain, G.; Lin, G.; Hayat, N.** 2010. A new parameter and its effect on the formability in single point incremental forming. A fundamental investigation, *Journal of Mechanical Science and Technology* 24: 1617-1621.
<http://dx.doi.org/10.1007/s12206-010-0514-1>.
 10. **Durante, M.; Formisano, A.; Langella, A.** 2010. Comparison between analytical and experimental roughness values of components created by incremental forming, *Journal of Materials Processing Technology* 210: 1934-1941.
<http://dx.doi.org/10.1016/j.jmatprotec.2010.07.006>.
 11. **Silva, M.; et al.** 2011. Failure mechanisms in single-point forming of metals, *International Journal of Advanced Manufacturing Technology* 56: 893-903.
<http://dx.doi.org/10.1007/s00170-011-3254-1>.
 12. **Bhattin, K.; Sridhar, T.** 2011. Design and analysis of a reconfigurable discrete pin tooling system for molding of three-dimensional free-form objects, *Robotics and Computer-Integrated Manufacturing* 27: 335-348.
<http://dx.doi.org/10.1016/j.rcim.2010.07.017>.
 13. **Kumar, S.** 2009. Manufacturing of WC-Co moulds using SLS machine, *Journal of Materials Processing Technology* 209: 3840-3848.
<http://dx.doi.org/10.1016/j.jmatprotec.2008.08.037>.
 14. **Wang; et al.** 2011. A method for representation of component geometry using discrete pin for reconfigurable moulds, *Advances in engineering Software* 42: 409-418.
<http://dx.doi.org/10.1016/j.advengsoft.2011.03.004>.
 15. **Jeswiet, J.** 2005. Asymmetric incremental sheet forming, *Advanced Materials Research* 6-8: 35-58.
<http://dx.doi.org/10.4028/0-87849-972-5.35>.
 16. **Ham, M.; Jeswiet, J.** 2006. Single point incremental forming and the forming criteria for AA3003, *CIRP Annals* 55: 214-244.
[http://dx.doi.org/10.1016/s0007-8506\(07\)60407-7](http://dx.doi.org/10.1016/s0007-8506(07)60407-7).
 17. **Hagan, E.; Jeswiet, J.** 2004. Analysis of surface roughness for parts formed by computer numerical controlled incremental forming. *Proc. IMechE. Journal of Engineering Manufacture* 218: 1307-1312.
<http://dx.doi.org/10.1243/0954405042323559>.

M. Rimašauskas, K. Juzėnas, R. Rimašauskienė, E. Pupelis

VIENO TAŠKO PALAIPSNIO FORMAVIMO PROCESO TYRIMAS KOMPOZITŲ FORMOMS GAMINTI

R e z i u m ė

Straipsnyje analizuojamos galimybės pritaikyti palaipsnio formavimo technologiją kompozitinių gaminių formų gamybai. Pateikti formuojamumo tyrimo, naudojant vieno taško palaipsnį formavimą, rezultatai. Ši technologija ypatingai tinka naujų, vienetinių gaminių ir prototipų gamyboje. Publikacijoje pristatyta sukurta technologinė įranga skirta palaipsniui metalo lakšto formavimui. Eksperimentiniame Tyrime naudoti AW5754 ir AW1050 aliuminio lydinių lakštai. Analizuota detalės (kompozitinių detalių gamybos formos) geometrinių parametru įtaka lakšto formuojamumui ir gaminio savybėms.

M. Rimašauskas, K. Juzėnas, R. Rimašauskienė, E. Pupelis

THE RESEARCH OF SINGLE POINT INCREMENTAL FORMING PROCESS FOR COMPOSITE MOULD PRODUCTION

S u m m a r y

The article presents results of analysis of applications of incremental forming technology for production of composite moulds. Results of the research of formability of sheet metal based on single point incremental forming are presented. This technology is particularly useful for manufacturing new prototypes and moulds for composite structure manufacturing. The publication introduces new technological equipment for incremental sheet metal forming. The research was performed using sheet blanks of aluminium alloys AW5754 and AW1050. The article analyses the influence of geometrical parameters of parts (moulds for composites forming) on formability of sheet metal and influence on the product properties.

Keywords: composite tooling, single point incremental forming.

Accepted March 21, 2014

Received August 20, 2014