

Research of the Converter Control Possibilities in the Grid-tied Renewable Energy Power Plant

C. Ramonas¹, V. Adomavicius¹

¹The Centre of Renewable Energy, Kaunas University of Technology,
Studentu St. 48-329, LT-51367 Kaunas, Lithuania
ceslovas.ramonas@ktu.lt

Abstract—Results of research of the converter control possibilities in the grid-tied renewable energy power plant are presented in this paper. Converter of the power plant consists of the DC chopper and the grid-tied inverter connected in series. Quality of the converter operation depends both on the DC chopper and inverter operation. Two ways of the converter operation control were researched: control of the DC chopper operation and control of the grid-tied inverter operation. Combination of both ways of the converter operation control has to be applied in order to achieve maximum available power production and the best parameters of the converter operation quality, such as maximum available efficiency of the power plant and minimum total harmonic distortion factor.

Index Terms—Pulse inverters, DC-DC power converters, distributed power generation.

I. INTRODUCTION

Development of the distributed power systems based on renewable energy sources (RES) requires more and more converters of various types and capacities. Number of installed power electronics converters definitely will increase together with the process of microgrids development. Microgrids mostly are designed for the more concentrated integration of the small-scale RES-based distributed power plants where every power source or power storage system usually has its own grid-tied inverter. Big number and considerable cumulative capacity of the power electronic conversion systems which include grid inverters operating in the local distribution grid may have negative aspects on quality of the power parameters [1]. Therefore additional power electronic equipment is necessary in some cases for feeding of loads, which are sensitive to the voltage distortion of the power source [2].

II. OBJECT OF RESEARCH

Object of the research is converter designed mainly for various renewable energy power plants. It contains the intermediate DC-DC power converter connected after the usually unstable primer renewable power source and grid-tied inverter. Such power conversion system and its peculiarities were described in preceding papers of authors – [3], [4] and other. In general, the converter can be applied for power conversion and supply into electric grid from any DC power source having variable DC voltage in the input of

the converter. The proposed converter is also suitable for operating with several renewable energy sources of various types and different capacities [3]. Also, this converter equipped with suitable control system is able to perform maximum power point tracking function in the solar or wind power system depending on the signals of the necessary sensors [4]. The tentative researches previously performed by authors shows that such power systems have a particular possibility to control the inverter's reactive power by adjusting the phase of modulation voltage in respect of the grid voltage [3].

Results of the converter control possibilities in the small-scale grid-tied renewable energy (RE) power system are presented in this paper. Simplified electrical scheme of the researched system is shown in Fig. 1. The electrical scheme consists of the following three parts: the DC voltage source U_s , the DC chopper and the grid-tied inverter. The DC chopper converts variable voltage value of DC source to DC voltage value suitable for the grid-tied inverter. Single phase grid-tied H-bridge inverter with power storage capacitor C_k is used for the power supply into the grid. Preliminary research of the authors shows that this scheme of power conversion allows controlling reactive power of the system by changing phase of the modulation voltage of the inverter. As it is shown in Fig. 1, here exists two ways of system operation control: control of the DC chopper operation (reference signal U_v and unit SCPF) and control of the grid-tied inverter (reference signals U_f , U_{FI} and units IMVF, IPF). It is evident that operation of DC chopper unit and inverter unit make some impact one to another. Control systems of the RE power sources must operate in order to ensure the maximum available power production at any usable value of renewable energy.

The PW modulation with constant carrier frequency is used to control DC chopper output voltage. The reference signal U_v is passed to the former of shorting transistor control pulses SCPF where control pulse of necessary width is formed for the transistor V_t in order to get the necessary output voltage. Modulation voltage former IMVF of the inverter forms the modulation voltage – the sinusoidal signal with the magnitude depending on the modulating factor with the frequency adjusted by the signal U_f and with the phase adjusted by the signal U_{FI} . This signal is passed to the former of the inverter transistors control pulses IPF where control pulses of necessary width are formed for the transistors $V_1 \div V_4$.

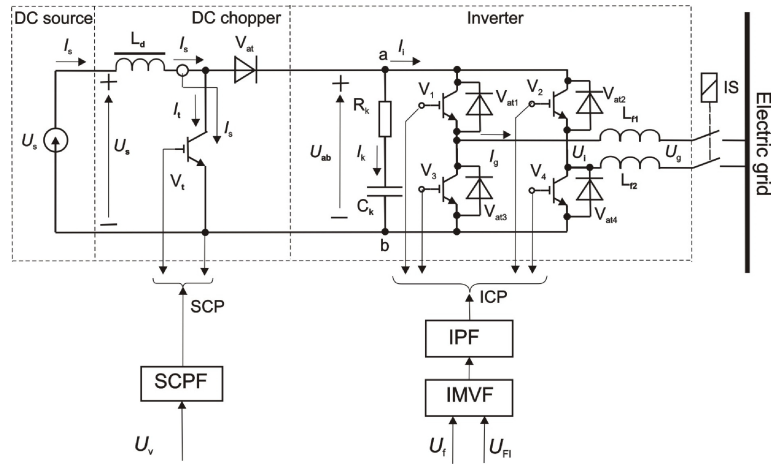

Fig. 1. Simplified electrical scheme of the small-scale grid-tied power system.

III. INVESTIGATION OF THE SYSTEM OPERATION

Mathematical description of the system comprised of DC chopper and grid-tied inverter have been described in the previous publications of authors [3], [4]. The goal of this work is to research control possibilities of the system. The PV source here (Fig. 1) is substituted by the absolute DC voltage source in order to facilitate the research of system controllability.

The DC chopper operation process consists of two intervals: short-circuit mode (transistor V_i is ON) and energy transferring to the inverter input (transistor V_i is OFF). During the short-circuit interval, when the transistor V_i is ON, the energy is accumulated in the inductance L_d of the inductor. The energy transferring interval occurs when transistor V_i is switched off. The energy from the inductor L_d is transferred to the inverter input and farther to the grid. The equivalent one phase scheme for average values of the power system with taking in account preconditions well known in power electronics is presented in the Fig. 2

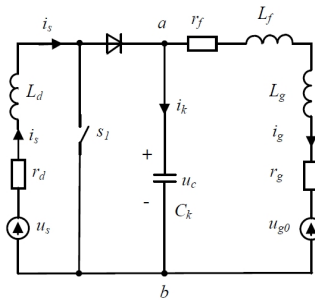

Fig. 2. The equivalent scheme of the power system.

The duty cycle of DC chopper is expressed as follows:

$$\gamma = \frac{\tau}{T_c}, \quad (1)$$

where γ - the duty cycle, τ - the time interval for which transistor V_i conducts, T_c - the chopping period, $f_c = 1/T_c$ - the chopping frequency. The interval of short-circuit occurs when switch s_1 is ON. It can be described as follows

$$T_d \frac{di_s}{dt} + i_s = \frac{1}{r_d} u_s. \quad (2)$$

After the taking Laplace transformation

$$T_d [si_s(s) - I_s(0)] + i_s(s) = \frac{1}{r_d} \frac{u_s}{s}, \quad (3)$$

where u_s - the internal voltage of the DC source, $T_d = L_d/r_d$ - the time constant of inductor, L_d - the inductance of inductor, r_d - the resistance of inductor.

At $t = 0$, initial current $I_s(0) = I_{min}$ and

$$i_s(s) = \frac{u_s}{L_d s \left(s + \frac{1}{T_d} \right)} + \frac{I_{min}}{\left(s + \frac{1}{T_d} \right)}. \quad (4)$$

Solution of the equation can be obtained by taking inverse Laplace transformation

$$i_s(t) = \frac{u_s}{r_d} \left(1 - e^{-\left(\frac{t}{T_d} \right)} \right) + I_{min} e^{-\left(\frac{t}{T_d} \right)}. \quad (5)$$

This equation is valid for $0 \leq t \leq \tau = \gamma \cdot T_c$, i. e., during the interval transistor V_i is ON. At the instant when transistor V_i is OFF or at the end of short-circuit interval, the load current

$$i_s(\gamma T_c) = I_{max} = \frac{u_s}{r_d} \left(1 - e^{-\left(\frac{\gamma T_c}{T_d} \right)} \right) + I_{min} e^{-\left(\frac{\gamma T_c}{T_d} \right)}. \quad (6)$$

The energy is accumulated in the inductance of inductor through the short-circuit interval can be expressed as follows

$$E = \int_0^{\gamma T_c} u_s i_s(t) dt, \quad (7)$$

$$E = \frac{u_s^2 T_c}{r_d} \gamma + \frac{u_s (u_s - r_d I_{min})}{L_d} \left(e^{-\frac{r_d T_c}{L_d} \gamma} - 1 \right). \quad (8)$$

The load current can be continues or discontinues depending on the duty cycle γ and the inductance L_d of inductor. For the continues operation the load current is considered changing between two limits I_{min} and I_{max} . For the load current discontinues operation the I_{min} is equal to 0.

Then (7) changes as follows

$$E = \frac{u_s^2}{r_d} \left[T_c \gamma + \frac{1}{T_d} \left(e^{-\frac{r_d T_c}{L_d} \gamma} - 1 \right) \right]. \quad (9)$$

Inductance of the inductor must be sufficient for the accumulating of this energy amount. It can be calculated respectively for load current continues or discontinues operation by using (7) or (8) and inductance value can be calculated as follows

$$L_d = \frac{2}{I_s^2} \left[\frac{u_s^2 T_c}{r_d} \gamma + \frac{u_s (u_s - r_d I_{\min})}{L_d} \left(e^{-\frac{r_d T_c}{L_d} \lambda} - 1 \right) \right], \quad (10)$$

$$L_d = \frac{2u_s^2}{r_d I_s^2} \left[T_c \gamma + \frac{1}{T_d} \left(e^{-\frac{r_d T_c}{L_d} \gamma} - 1 \right) \right]. \quad (11)$$

Mathematical description of the inverting processes was presented in the previous publication of authors [4] and therefore it will be skipped. Further investigation of the system is performed by means of digital simulation.

IV. MATHEMATICAL MODEL OF THE RESEARCHED SYSTEM

Method of digital simulation with applying MATLAB/SIMULINK program package is used for research of the system. Digital model of the system is based on the SymPowerSystems library. Overall model diagram of the researched system is presented in Fig. 3.

This model consists of the following units: DC chopper, the inverter, the grid voltage source u_{g0} , the active resistance and inductance of the grid R_g and L_g , the inductances of the filter L_{f1} and L_{f2} , the measurement units for the active and reactive power P , Q and the measurement units for current I_g and for voltages U_i , U_{g0} , U_g and U_d . Constant block F_{im} refers phase value of the modulation voltage of inverter.

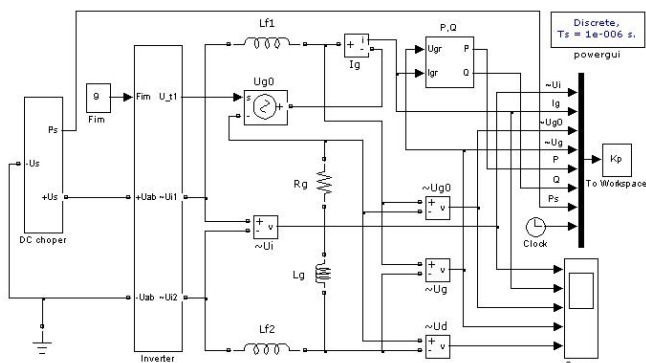

Fig. 3. Model diagram of the researched power system.

Model of the DC chopper is shown in Fig. 4. It consists of the power circuit and controller. Power circuit consists of DC voltage source, resistance R_d and inductance L_d of inductor, chopping transistor $Vt1$ and flyback diode Vat . Controller generates pulses for transistor $Vt1$. Block Uv_ref refers width of pulses.

Average values of main parameters which characterize operation of DC chopper are measured because steady state operation of DC chopper is researched. The display blocks indicate values of the observed parameters.

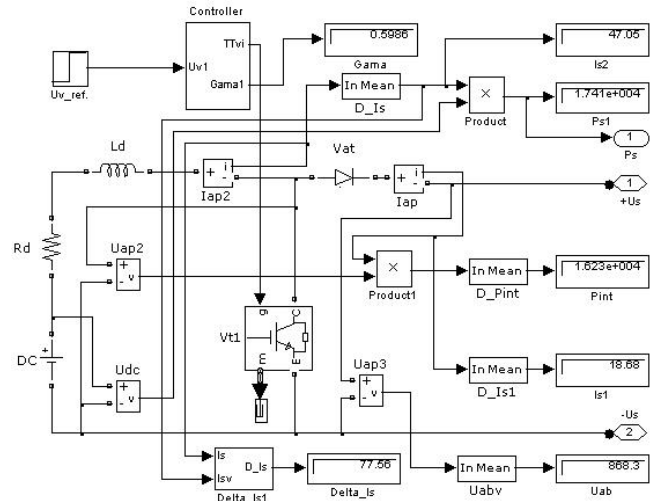

Fig. 4. Model diagram of the DC chopper.

Model of the inverter is used the same as it was in the previous publication of the authors [3].

V. RESULTS OF THE RESEARCH

The main target of research was analysis of the control possibilities of grid-tied renewable energy power plant converter (Fig. 1). Total harmonic distortion (THD) is also considered as one of the essential parameters of grid inverters [5], [6]. Existence of the DC chopper and the grid-tied inverter allows controlling of the converter by using DC chopper control or/and inverter control. DC chopper operation control is performed by changing control voltage of DC chopper U_v ($U_v = 10\gamma$, V) which refers duty cycle γ with constant chopping frequency f_c . Other chopping frequencies also can be used. Results of research for this control manner are shown in Fig. 5 and Fig. 6.

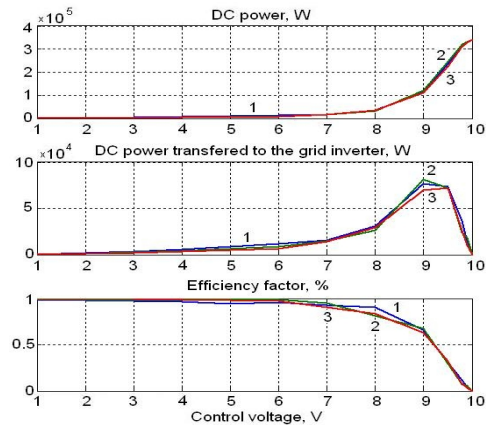

Fig. 5. Curves of the power system parameters versus control voltage for three chopping frequencies (1-1800 Hz, 2-2800 Hz, 3-3800 Hz).

These curves illustrate operation of DC chopper dependently on the control voltage for three cases of chopping frequency. Figure 5 shows that output power of the DC chopper, power transferred to the inverter and efficiency factor changes in the range of duty cycle from 0.1 to 0.7 according to the law close to linear. Impact of the chopping frequency to DC chopper parameters is negligible. It means that real range of duty cycle control lies in boundaries from 0.1 to 0.7.

Figure 6 shows that increase of DC chopper control voltage causes increasing of DC voltage on the inverter

terminals and THD of the grid voltage, meanwhile decreasing THD of the grid current. This peculiarity can be used for the control of converter. These curves also confirm that real range of duty cycle control lies between the boundaries from 0.1 to 0.7.

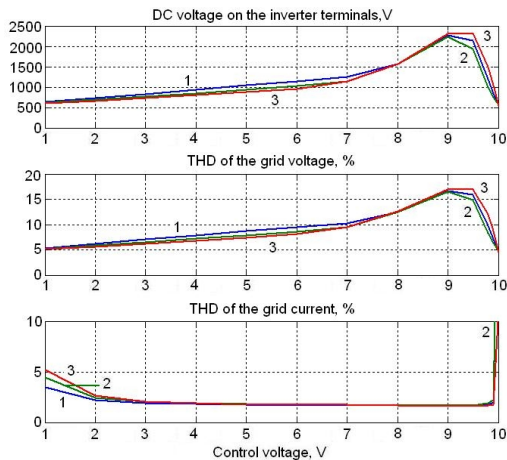

Fig. 6. Curves of the inverter DC voltage and THD of the grid voltage and current versus control voltage for three chopping frequencies (1 Hz-1800 Hz, 2 Hz-2800 Hz, 3 Hz-3800 Hz).

The converter control by means of inverter control is performed by changing the phase of the inverter modulation voltage [7]. Figure 7 and Fig. 8 illustrate operation of converter dependently on the phase of inverter modulation voltage for the three cases of the chopper control voltage value.

The presented curves show changes of the converter main parameters depending on the phase of inverter modulation voltage.

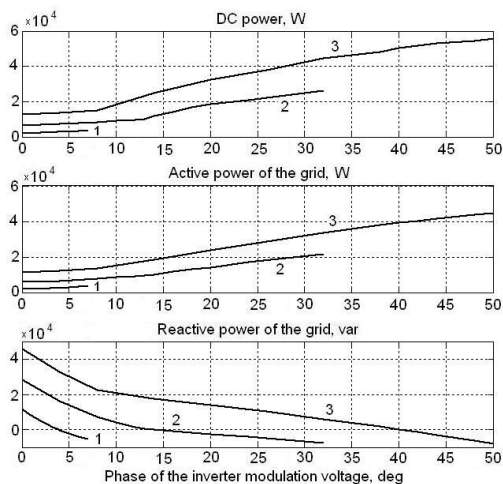

Fig. 7. Curves of the power system parameters versus phase of the inverter modulation voltage for three values of the DC chopper control voltage: 1 - $U_v = 2$ V, 2 - $U_v = 4$ V, $U_v = 6$ V, ($f_c = 1800$ Hz).

All curves shown in Fig. 7 and Fig. 8 have turning-points, after which the declination of curves is changing. Investigation of this phenomena by means of simulation showed that in these points DC chopper operation changes from the discontinues to the continues current.

Practically the DC chopper control and grid-tied inverter control can be used together in order to receive maximum available efficiency of operation.

Figure 8 also shows the possibility to control the DC voltage on the inverter terminals and THD of the grid

voltage by means of the inverter modulation voltage phase.

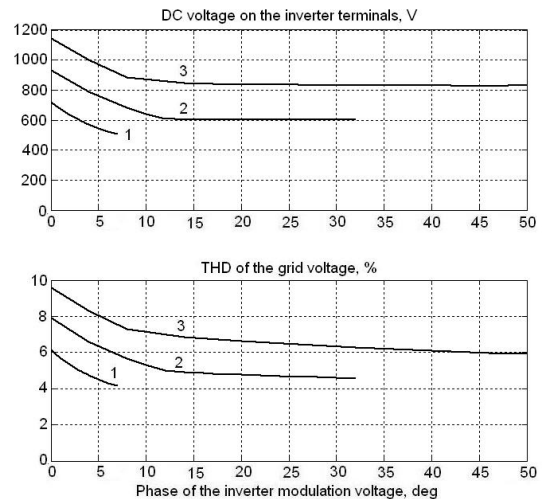

Fig. 8. Curves of the DC voltage on the inverter terminals and THD of the grid voltage versus phase of the modulation voltage for 3 values of the DC chopper control voltages: 1 - $U_v = 2$ V, 2 - $U_v = 4$ V, 3 - $U_v = 6$ V, ($f_c = 1800$ Hz).

VI. CONCLUSIONS

Possibilities of the converter operation control were investigated by means of digital simulation of the DC chopper control and grid-tied inverter control. Methodology for calculation of inductance of the inductor of DC chopper was proposed. The simulation revealed that parameters of the DC chopper begin non-linear wide variations after the value of duty cycle exceeds 0.7 boundaries. It allows concluding that acceptable limits of duty cycle are 0.1–0.7.

DC voltage on the inverter terminals, reactive power supplied into the grid and THD of the grid voltage sharply decreases when the phase angle of the modulation voltage increases and the DC chopper operates in the mode of discontinues currents. Both ways of control can be applied for achieving of the most efficient operation of converter.

REFERENCES

- [1] W. R. Ryaert, K. De Gussem, D. M. Van de Sype, J. A. Ghijselen, J. A. Melkebeek, "Reduction of the voltage distortion with a converter employed as shunt harmonic impedance", *Twentieth Annual IEEE Applied Power Electronics Conf. and Exposition, APEC 2005*, vol. 3, pp. 1805–1810.
- [2] Y. Han, "Power balancing mechanism and controller design for the single-phase cascaded H-bridge", *Elektronika ir Elektrotechnika (Electronics and Electrical Engineering)*, no. 1, pp.15–18, 2013.
- [3] C. Ramonas, V. Adomavicius, "Grid-tied converter with intermediate storage chain for multipurpose applications", *Elektronika ir Elektrotechnika (Electronics and Electrical Engineering)*, no. 7, pp. 15–20, 2011.
- [4] C. Ramonas, V. Adomavicius, "Impact of DC/DC converter parameters on operation of solar power conversion system", in *Proc. of the 6th Int. Conf. on Electrical and Control Technologies ECT 2011*, Technologija, pp. 321–324, 2011.
- [5] B. R. Lin, T. Y. Yang, "Implementation of active power filter with asymmetrical inverter legs for harmonic and reactive power compensation", *Electric Power Systems Research*, Elsevier, vol. 73, 2005, pp. 227–237. [Online]. Available: <http://dx.doi.org/10.1016/j.eprsr.2004.08.007>
- [6] P. Görbe, A. Magyar, K. M. Hangos, "THD reduction with grid synchronized inverter's power injection of renewable sources. International symposium on power electronics", in *Proc. Electrical Drives and Motion SPEEDAM 2010*, pp. 1381–1386.
- [7] C. Ramonas, V. Adomavicius, "Research of the reactive power control possibilities in the grid-tied PV power plant", *Elektronika ir Elektrotechnika (Electronics and Electrical Engineering)*, vol. 19, no. 1, pp. 31–34, 2013.