

Vibroactive Pad Improvement Using Stack Type Piezoactuator

R Šakalys¹, A Palevičius and G Janušas

International Studies Centre, Kaunas University of Technology,
A.Mickevičiaus str. 37, LT-44244 Kaunas

E-mail: rokas.sakalys@ktu.lt

Abstract. Previously created vibroactive pad encounters with a problem, i.e. vibrations are not fully descended, since amplitudes of vibroactive pad are lower. In microstructure replication process it causes insufficient flow of fluid, since it is directly dependent on the amplitude of excitation. As a solution for this problem stack type piezoactuator together with vibroactive pad of new construction are proposed. It is known, that stack type piezoactuators are able to reach higher amplitudes, than single piezoceramics can do, thus it is considered as a solution, in order to overcome previously mentioned problem. In this paper new construction of vibroactive pad is presented and numerically analyzed using Comsol Multiphysics 3.5a. software in order to determine its natural frequencies.

1. Introduction

Hot imprint is slightly becoming one of the most promising techniques (due to advantages like, low cost, relatively simple equipment, when comparing with injection molding and others), used in order to replicate high precision structures, which later could be used for many different purposes. On the other hand it is necessary to overcome many challenges, in order to reach replicas of superior quality. These difficulties include residual gas inside the replica, as well damage of replica, during demolding step, due to friction between two surfaces (mold and replica itself). As well it is relatively time consuming procedure, since replica (for example, made from polymer) should be heated above its glass transition temperature, in order to melt the material, thus forcing it to fill the shape of the impressed mold. This problem- long cycle time makes hot imprint less attractive for mass production. The last challenge is lower molding rate in the center of the mold, since there acts lower contact force, than in the edges of the master mold [1-2].

As a single solution for listed problems, ultrasonic vibrations could be proposed. This measure could be used in order to create intermolecular friction between the molecules of polymer [1], as the polymer is pressed, thus increasing its temperature and forcing to melt and decreasing process time [2]. As well ultrasonic vibrations help to avoid residual gases inside the replica, and during the demolding step allow avoid damaging of replica by decreasing the friction [1].

Previously vibroactive pad was proposed as a generator of high frequency vibrations [3]. The main difference between improved and old vibroactive pads is that pad, based on stack type piezoactuator is able to reach higher amplitudes.

In this paper stack type piezoactuator will be used as a fundament in order to compose whole construction, which will be used as vibroactive pad with stack type piezoactuator, instead of single piezoelectric ring. First of all geometrical modeling will be performed with SolidWorks software. As it is explained earlier in this paper, high frequency vibrations is the factor, which positively influences the quality of replicas [3]. In order to employ the stack type piezoactuator as vibroactive pad it is necessary to know its natural frequencies. It would be very inefficient to find working regimes experimentally, since it would cost a lot of time and money. To perform such an analysis experimentally would lead to higher time and money expenses, thus geometrical drawing created with

¹ Corresponding author

SolidWorks will be exported to COMSOL Multiphysics 3.5a., where it will be numerically analyzed in order to find its natural frequencies and represent vibration modes [4-5].

2. Design of vibroactive pad, based on stack type piezoactuator

28mm length ($L=28\text{mm}$) stack type low voltage piezoactuator of model PSt 150/4/20 VS9 (Fig. 1), made by PiezoMechanik company, was selected as a source for generation of high frequency vibrations. This actuator generates longitudinal high frequency vibrations.



Figure 1. The stack type piezoactuator made by PiezoMechanik.

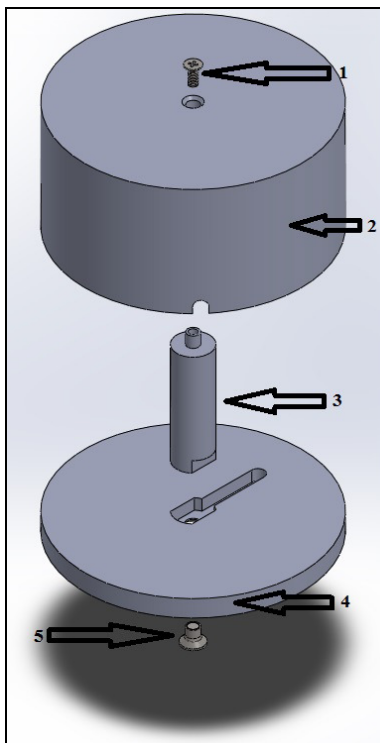

Figure 2. Exploded view of vibroactive pad composed from: M2 bolt (1); covering (2); stack type piezoactuator (3); base (4) and M3 bolt (5).

First of all this actuator is geometrically designed by using SolidWorks software. Next step is to create the external frame for actuator, since it is necessary to secure this actuator from external pressure during hot imprint process. Aluminum was chosen as a material for the production of frame,

since it has low Young's modulus, in other word its stiffness is lower and in the same time lower natural frequency. Exploded view of the whole construction is presented in Fig. 2.

As it can be seen vibroactive pad is composed from the base, which has the groove for stack type actuator and its wiring. As well there is hole for M3 bolt, which fixes the base with the stack. Next part is the covering, which has the hole for wiring and the hole on the top for M2 bolt, which finally fixes the construction.

After having drawn this construction in SolidWorks it is possible to export it to COMSOL Multiphysics 3.5a., in order to numerically analyze it and determine its natural frequencies

3. Numerical analysis of vibroactive pad

In this chapter modeling of vibroactive pad, based on stack type piezoactuator, which will be employed as frequency generator in hot imprint process is presented.

The natural frequencies of vibroactive pad were numerically analyzed using finite element method. The dynamic parameters of the vibroactive pad (Fig. 2) were calculated using program COMSOL Multiphysics 3.5a.

The geometrical parameters of vibroactive pad are as following: base thickness is 4.7mm, thickness of covering is 5mm, and total height of the vibroactive pad is 34.7mm. During the modeling vibroactive pad's bottom surface is fixed.

The pad's material is aluminum and the stack is modeled structural steel from the outside and PZT-4 rings inside. The properties of materials were taken from COMSOL Multiphysics 3.5a. material library.

4. Results

Results of numerical simulation, which was used in order to determine natural frequencies of newly designed vibroactive pad are presented in Figure 3..

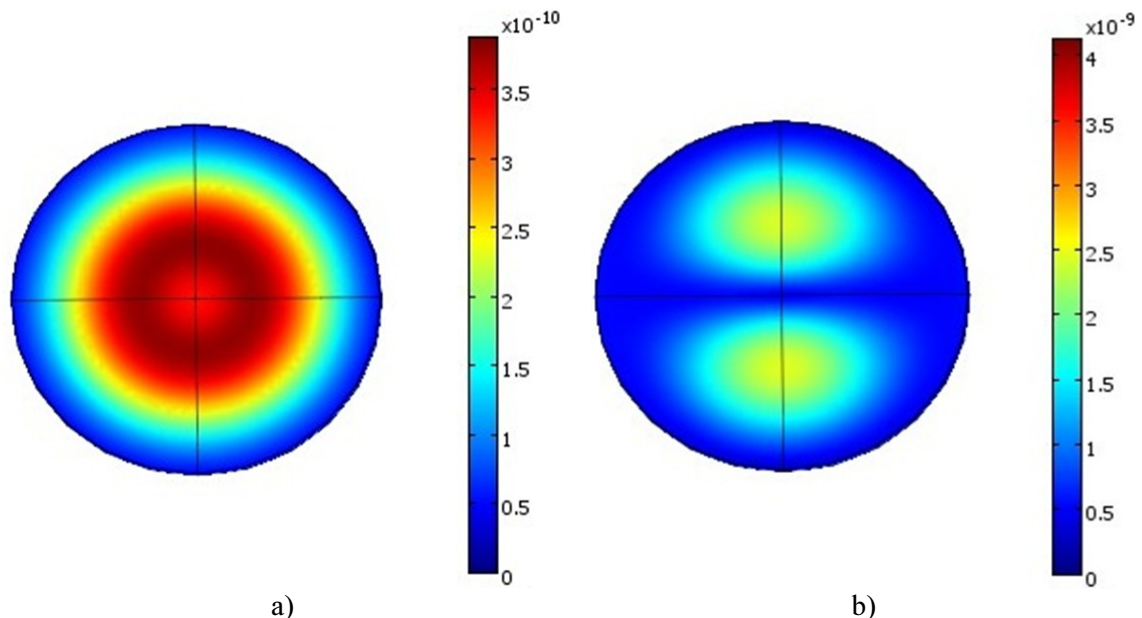

Figure 3. Vibration modes of vibroactive pad: 20.4kHz (a), 21.2kHz (b).

According to COMSOL Multiphysics 3.5a. first two vibration modes are obtained at these frequencies: 20.4 and 21.2kHz. The next step in the future would be to analyze response of the vibroactive pad to high frequency excitation, when it is under the action of mechanical load of $5.06 \cdot 10^5$ Pa (what corresponds to hot imprint process) and without.

5. Conclusions

Vibroactive pad, based on stack type piezoactuator was designed and numerically analyzed in order to determine its natural frequencies. Two vibration modes and natural frequencies of the vibroactive pad were determined after the modeling. First two natural frequencies of vibroactive pad based on stack type piezoactuator are: 20.4 and 21.2kHz.

Acknowledgments

This research was funded by a grant (No. MIP-060/2012) received from the Research Council of Lithuania.

References

- [1] Mearu H, Goto H and Takahashi M 2007 Development of ultrasonic micro hot embossing technology *Microelectronic Engineering* **84** 1282–1287
- [2] Liu J S, Dung Y T 2005 Hot Embossing Precise Structure Onto Plastic Plates by Ultrasonic Vibration *Polymer Engineering and Science* **45** 915–925
- [3] Narijauskaitė B, Palevičius A, Narmontas P, Ragulskis M and Janušas G 2012 High-frequency excitation for thermal imprint of microstructures into a polymer *Experimental Techniques* (Malden: Wiley-Blackwell Publishing) 1–7
- [4] Gaidys R, Narijauskaitė B, Palevičius A and Janušas G 2012 Numerical simulation of hot imprint process of periodical lamellar microstructure in to polycarbonate *Micromachining and microfabrication process technology XVII* (Bellingham: SPIE) **8248** 1–9
- [5] Janušas G, Palevičius A and Palevičius R 2009 Some methodological aspects of usage COMSOL multiphysics in teaching fundamentals of computational mechanics *Global Cooperation in Engineering Education: Innovative Technologies* (Kaunas: Technologija) 151–156