

Pressure vessel with corrugated core numerical strength and experimental analysis

A. Žiliukas*, M. Kukis**

*Kaunas University of Technology, Kęstučio 27, 44312 Kaunas, Lithuania, E-mail: antanas.ziliukas@ktu.lt

**Kaunas University of Technology, Kęstučio 27, 44312 Kaunas, Lithuania, E-mail: mindaugaskukis@yahoo.com

crossref <http://dx.doi.org/10.5755/j01.mech.19.4.3204>

1. Introduction

The contemporary industry is saving metals and facilitating the constructions with an aim to optimally use metal resources. The manufacturing of products made of monolithic metals has been replaced by alternative constructions such as cellular plates and vessels [1]. An example of a cellular construction is given in Fig. 1.

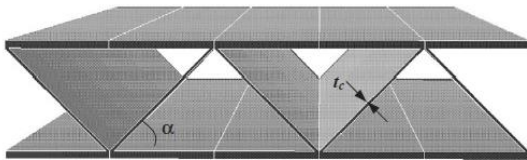

Fig. 1 Cellular plate with corrugated core is made of sheet steel [1]

In their work [2], Chae-Hong Lim, Insu Jeon and Ki-Ju Kang present a new study of economical sandwich plates with periodic cellular core. Construction's production is based on the expanded metal formation. The study was conducted in two stages: the numerical method using the finite element calculation method software ABAQUS and the experiment. The research is performed by compressing the construction, bending the two ends and fixing. The proposed construction has proven its worth by complying to three requirements set in advance: morphology, production costs and as a raw material.

The article [3] closely examines the sandwich plate with prismatic truss core. Multifunctionality of the examined plates – a lightweight board able to simultaneously perform the cooling function, and overcome the blast resistance. In order to determine the plate's mechanical properties, the article suggests a protocol for characterizing the structural performance consisting of measurements, mechanism maps, finite element analysis and optimisation. The mechanism maps are intended for the selection of the appropriate elements of the parameters and the minimum weight. Numerical investigations and trials are required for the understanding of the core operation in transverse compression, in-plane shearing and stretching. Results of the comparison between calculation and trial methodologies reveal that the calculation results may still be operated in designing the constructions.

In their work about the method of zigzag-formed truss core, Heon Kim and Ki-Ju Kang [4] examine their mechanical characteristics. The examined zigzag core plates are described in analytical formulas and then the trials are conducted. The plates were examined by shearing and compressing. After performing the strength analysis, the plates with zigzag rod layout, are equivalent to the

plates with pyramidal core. The authors emphasize the advantage of this design - this type of core construction can be made of a simple and cheap raw material – a wire.

If the monolithic construction walls would be replaced by the aluminium foam plate walls – the flexural stiffness would be increased several times. If the aluminium foam plate would replace the monolithic wall of the same stiffness, the wall's weight would be reduced by the size of the monolithic wall's thickness. These plates can also very well absorb vibrations and energy. Aluminium plates also show excellent results in heat dissipation [5-7]. If the aluminium foam plates were used in the automotive industry, the traditional parts would be replaced by sufficiently stiff and light ones, so the number of frame components would be reduced, the assembly would be facilitated, and the costs would be lower, while it would also improve the functioning [8].

In his work, David J. Sypeck [9] presents a relatively new but very cheap type of sandwich panels produced from wrought steel. The manufacturing of these plates requires textile metal derivative or perforated sheets. The core plates produced in this way are relatively lightweight and, due to the truss insert, perform cooling function. Moreover, such plates absorb the crushing energy, while also being strong and stiff.

As it has already been mentioned before, the perfect sandwich panels can very well absorb the energy and crushing strength. In their work, Zhenyu Xue and John W. Hutchinson [10] investigate rectangular plates with honeycomb core. They observed that the plates are reliable for going out -of-plane shear and in-plane stretch. The article provides calculations using analytical formulas and analyses of the possible states performed using the commercial software ABAQUS. When the plates have to absorb significant amounts of energy in states of crushing loads, or intense pulsations, the dynamic effects start to affect the core type of behaviour: inertial resistance, inertial stabilization of webs against buckling and the material strain-rate dependence.

Examining the tube exposed at the internal moving pressure load, six different tube types were tested. The tubes chosen for the test had walls consisting of: Kagome, diamond, triangle-8, rectangle, and triangle-6 cores and monolith. Analytical formulas were written, and the strength calculations supporting those formulas were made. Some finite element simulations were performed in order to determine the structural effectiveness at different strain rates. Triangle-6 has been proved to be the most superior of all five cellular plates [11].

Metal cellular tubes exposed to internal moving shock load are examined in the works [12] of Jiayi Zhou,

Zichen Deng, Tao Liu and Xiuhui Hou. The prismatic core tubes are optimally constructed to the minimal mass. The prismatic cores stiffness matrix is determined by the homogenisation procedure. Optimal structures were confirmed by finite element simulations. The results show that the best of three topologies: square, triangular and Kagome is the square. Four-layer square core performed the best under heavy loads. Single-layer cores are unsurpassable in a case of low loads. Cellular tube, optimized for minimal mass, and optimized monolithic tube running internal pressure were compared and it was noticed that the cellular tube is heavier than monolithic. However, cellular plates are superior in their multi-functionality – cooling and heating functions and etc.

The work of T. Liu, Z.C. Deng and T.J. Lu [13] examines the hollow metal cylinders exposed at termomechanical conditioning. The selected rectangular and triangular cores were exposed to heat and forced air convection. The research showed that the eight layer cylinder with a rectangular core exceeds other topologies in terms of the heat transfer.

J.W. Hutchinson and M.Y. He [14] examine buckling of the sandwich cylindrical shells with a core consisting of metal foam core in axial compression. Optimal construction intended to sustain the load was designed during the examination, and it was lighter compared to the cylinder reinforced by stiffness. The influence of defects to the optimal construction was also examined.

Using analytical and numerical methods, Jiayi Zhou, Zichen Deng and Daolin Xu [15] are examining the sandwich tube operating in termomechanical conditions. The mechanical effect is an inner shock pressure. Findings of the investigation – constructing the sandwich tubes, the thermal effect should not be ignored.

As it has been proven by the analysis of these works, cellular constructions are examined more often, applying them to plates and there are too little works examining the cellular pressure vessels.

Therefore this paper includes:

1. numerical model of a cellular cylinder with a corrugated core design, which will be examined by loading the pressure, i.e. pressure vessel's strength analysis is performed, and the results are compared with a simple cylinder of the same weight;

2. experimental results, by producing the same cylinder with corrugated core.



Fig. 2 Steel pressure's water reservoir

The object of the research is a specially designed pressure vessel (Fig. 2.), intended to contain liquids, steam, gas and to hold their mixtures under elevated pressure (higher than atmospheric).

Definitions of pressure vessels vary in different countries, usually, the maximum safe pressure (which vessel can withstand), and the maximum product of pressure and volume (normally only in the gas phase) that indicates the potential energy of the current vessel are specified describing these vessels.

Pressure vessels are used in many areas: industry as well as science or household:

- compressed air tanks – skin-divers' air balloons, the air containers for pneumatic weapons, compressed air balloons designed to blow away the dust, pneumatic brake compressed air balloons and etc.;
- hot water tanks – e.g. in central heating systems;
- vessels of sterilization by water steam - medical and industrial sterilizers (autoclaves);
- distillation vessels - oil and petrochemical industries;
- premises - space ships, orbital stations, submarines;
- aerosol vessels - vessels with pressure nozzles designed for spraying the aerosols (e.g., hair spray, deodorant, etc.);
- compressed gas containers – balloons of acetylene, oxygen, chlorine, hydrogen, butane, propane and other gases.

Pressure vessels may be of any shape, but are usually spherical, cylindrical, conical, or mixed combinations of these forms are used. Other forms are used less frequently because it is difficult to estimate their mechanic resistance.

Theoretically, the optimal pressure form is a sphere, but vessels shaped in this way are difficult to produce and therefore are more expensive. The most commonly used form - cylinder, often with hemispherically shaped or similarly domed ends.

Pressure vessels are made of any material which withstands stretching and is chemically resistant to the materials, which will be held in the vessel. The most commonly used material is steel. Although welding can degrade the durability of steel, manufacturing the hemispheric pressure vessels the extruded parts are welded, strictly supervising the quality.

Pressure vessels are of a high risk, so their manufacturing and exploitation are closely supervised; it is governed by the special authorities, which work relying on the national and international standards for pressure vessels. The basic standard which is followed by the European Union in designing the pressure vessels is EN 13445 “Unheated pressure vessels”.

2. Numerical research methodology

This work examines the strength of the cellular cylinder with thick blind flanges. This is done by using the finite element system ANSYS.

In this way there will be examined:

1. cellular cylinder's numerical model with corrugated core design, which tested with pressure loading, i.e. vessel's strength analysis is performed, and the results are compared with the simple cylinder of a same mass;

2. experimental results, by producing the same cellular cylinder.

The examined cylinder's principled scheme is provided in Fig. 3.

Fig. 4 shows the cellular cylinder with constraints and loads examined for strength. Since the structure is vertically symmetrical, only half of the geometry is used simplifying the calculations. To preserve the symmetry, the construction is fixed so that it would not be displaced to sides. This is illustrated by the green side arrows. In order to limit the remaining degrees of freedom, displacements from the bottom are also limited, and the central point of the bottom is fixedly set. This is illustrated by the bottom green arrows. The red arrows indicate the load. In this case, the load is pressure and hydrostatic pressure of the water.

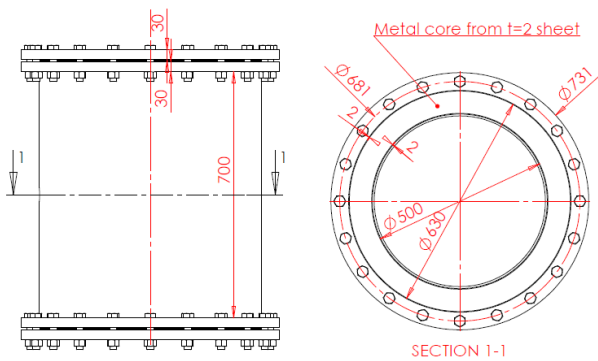

Fig. 3 Simplified specimen scheme

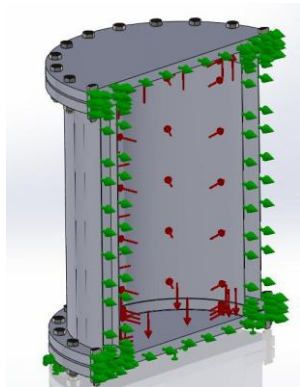

Fig. 4 Specimen consolidation and loading in testing strength

Mechanical characteristics of the sheet material (steel):

- elasticity module $E = 2 \times 10^5$ MPa;
- Poisson's coefficient $\nu = 0.3$;
- Yield strength (declared in material quality certificate) $\sigma_y = 304$ MPa;
- tensile strength (declared in material quality certificate) $\sigma_U = 407$ MPa.

Sheet material's (steel) chemical composition:

- Carbon (C) - 0.14%;
- Manganese (Mn) - 0.39%;
- Silicon (Si) - 0.01%;
- Sulphur (S) - 0.029%;
- Phosphorus (P) - 0.02%.

3. Experimental research methodology

Construction calculated by numerical methods is

verified by experiment. In this work, the vessel selected for trials has a corrugated core construction as shown in Figs. 5 and 6. The pressure vessel is tested by filling it with water and causing an internal pressure with the help of a compressed nitrogen balloon. The pressure is increased up to 4.5 bar every 0.5 bar. In each stage, displacements of the inner cylinder are measured, and it is conveyed by the rod welded to the cylinder which is located in the centre of the corrugated segment in the middle of the construction. The other end of the shank contains a plate which supports the displacement measure.

The measuring system consists of manometer and displacement measure. The manometer's accuracy class 1.6, measuring accuracy ± 0.1 bar, measuring range 0–6 bar. Displacement measure's accuracy class is 0.2, measuring accuracy ± 0.5 μm , measuring range 0–100 μm .

A specimen of 2 mm steel structural ST3PS sheet was used for this experiment.

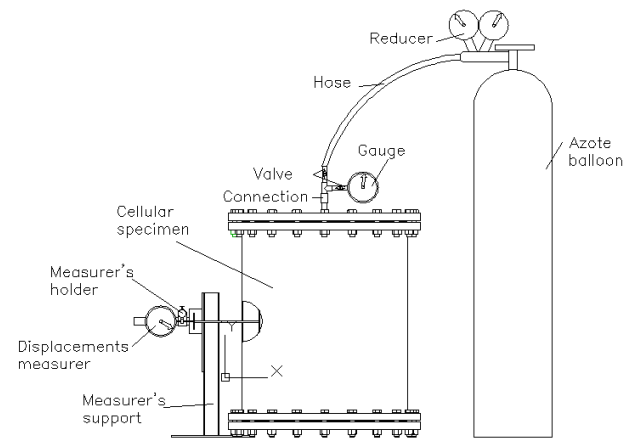

Fig. 5 Cellular vessel's trial stand

4. Cellular cylinder with a corrugated core strength research

A standard size cylinder (Fig. 3) with a core construction (Fig. 6) is examined.

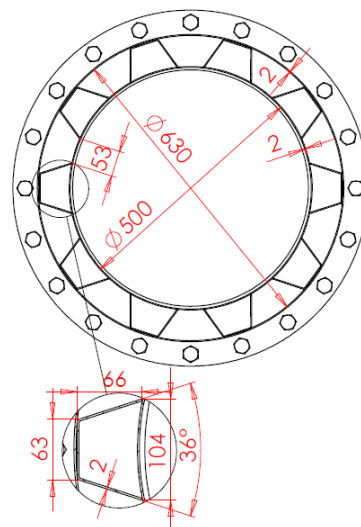

Fig. 6 Trial cellular's pressure vessel core construction

The strength calculation model was composed of 21032 SHELL63 type finite elements (20218 nodal

points). Fig. 7 presents the computational model which is divided to finite elements.

As the research is concerned only with the construction of the cylinder, blind flanges are eliminated and only the cylinder will be given as shown in Fig. 8.

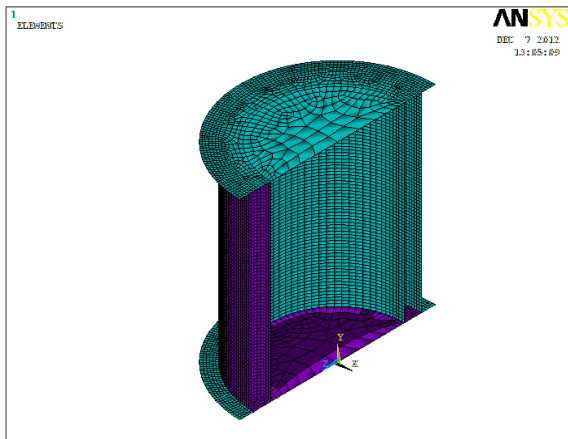

Fig. 7 Cellular cylinder with a corrugated core and blind flanges is divided by finite elements.

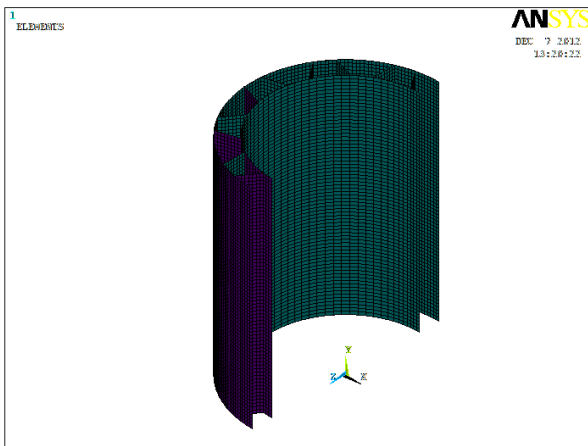

Fig. 8 Cellular cylinder with a corrugated core is divided by finite elements

Images of the construction being exposed to critical pressure due to which the system reaches the yield strength will be provided. After performing the calculations such pressure was proven to be $P = 9.35$ bar.

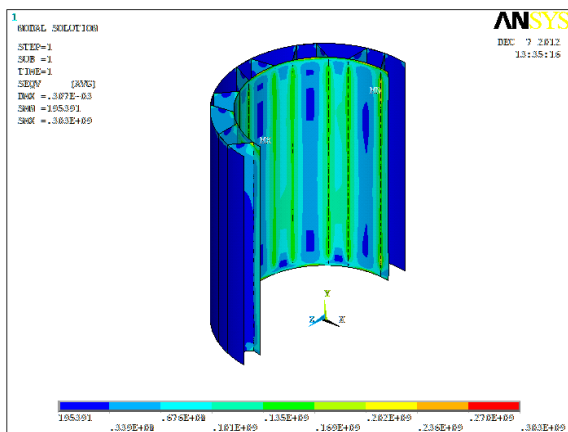

Fig. 9 Distribution of the reduced stress in a cellular cylinder with the corrugated core using Von Mises strength criterion

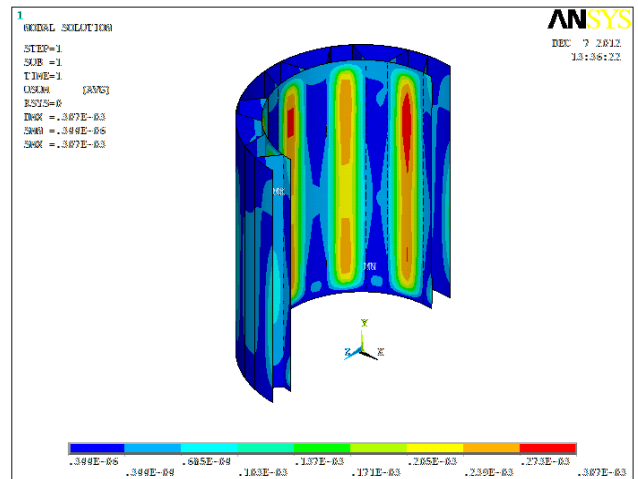

Fig. 10 Deformations in cellular cylinder with a corrugated core

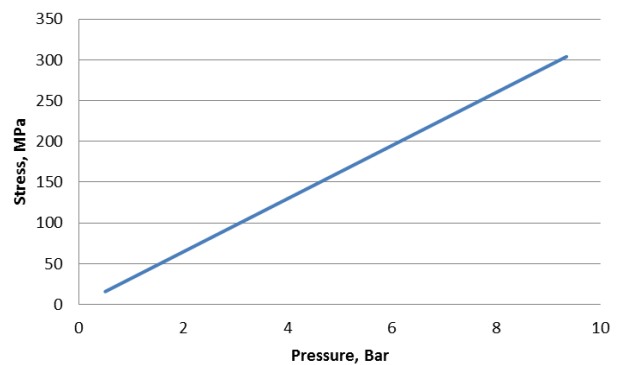

Fig. 11 Dependence of stress on pressure

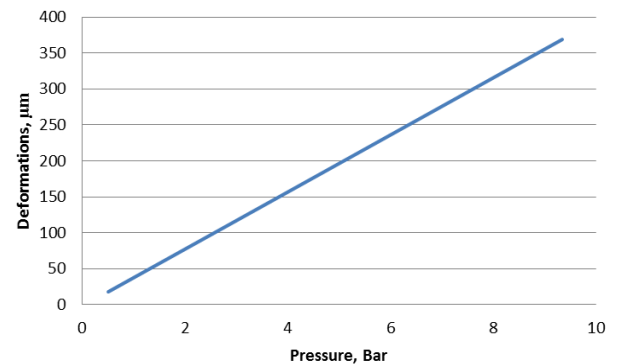

Fig. 12 Dependence of deformations on pressure

Calculation by loading $P = 9.35$ bar was carried out with a single cylinder. The outer diameter of the cylinder is the same as the cellular vessel's inner cylinder's diameter $\text{Ø}500$. After performing the calculation, it was proven that the solid cylinder, which has the same bearing capacity, is 1.42 times heavier than the cellular one.

The experiment was carried out to verify the historical accuracy of previous numerical studies. The central element displacement measurements were performed in the numerical model, by increasing the pressure every 0.5 bar to 4.5 bar, as shown in Fig. 13. The pressure was being increased to a specific value as at about 4.5 bar maximum displacements of the inner cylinder are achieved – 100 µm - which can be measured by the displacement measure. The experiment was repeated 20 times.

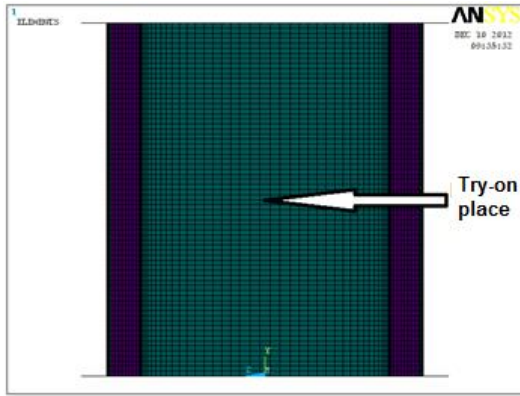

Fig. 13 Displacements measuring location

Numerical model and product for experimentation was produced as shown in Fig. 14.



Fig. 14 Location of measurement displacements in the trial. Image of an experimental case

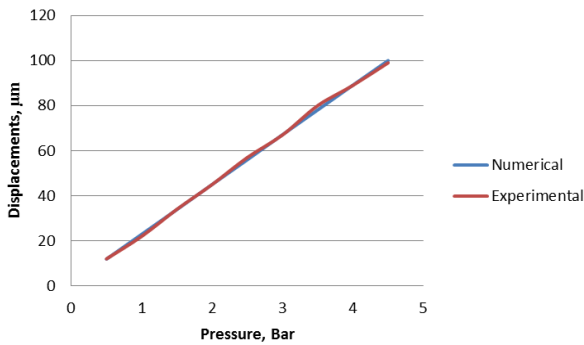

Fig. 15 The inner cylinder's central point displacement and pressure dependence's comparison

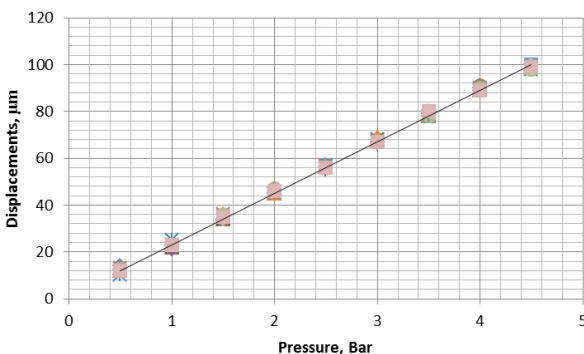

Fig. 16 The dependence of an inner cylinder's central point displacement and pressure (experimental data)

Table Summary of the experimental measurement results (with a confidence probability $\beta = 0.95$, relative error $\delta = 5\%$)

Pressure, bar	Average \bar{x}	Dispersion s^2	The coefficient of variation v , %	The required number of measurements n_r
0.5	12.2	1.07	8.5	13.9
1.0	22	0.89	4.2	3.6
1.5	34.2	0.18	1.2	0.3
2.0	45.3	0.46	1.5	0.43
2.5	56.3	0.23	0.9	0.4
3.0	68.8	1.87	2.0	0.8
3.5	78.5	0.28	0.7	0.1
4.0	90	0.89	1.0	0.2
4.5	99.3	0.68	0.8	0.13

5. Conclusions

1. The strength evaluation analysis of a vessel with core has shown that up to this day, cellular plates are examined in research and manufacturing more extensively, and the shells' carrying capacity and their advantages in comparison with the vessels made of integral materials have only rudimentary research.

2. The paper presents numerical research of a cellular cylinder with a corrugated core, conducted by loading the construction to its yield strength and calculating the reduced stress according to the strength criteria. The results have shown sufficient bearing ability of the chosen construction at a pressure of $P = 9.35$ bar.

3. The experimental research of the cellular cylinder of the same geometry have proven the numerical calculations to be correct.

4. Thus comparing the sizes of cellular cylinder and integral mass cylinder we have found out that under the same loads, the cellular cylinder is 1.42 times lighter than the integral cylinder.

References

1. **Hohe, J.; Librescu, L.** 2004. Advances in structural modeling of elastic sandwich panels, *Mechanics of Advanced Materials and Structures*, 11: 395-424. <http://dx.doi.org/10.1080/15376490490451561>.
2. **Lim, C.-H.; Jeon, I.; Kang, K.-J.** 2009. A new type of sandwich panel with periodic cellular metal cores and its mechanical performances, *Materials and Design* 30: 3082-3093. <http://dx.doi.org/10.1016/j.matdes.2008.12.008>.
3. **Zok, F.W.; Waltner, S.A.; Wei, Z.; Rathbun, H.J.; McMeeking, R.M.; Evans, A.G.** 2004. A protocol for characterizing the structural performance of metallic sandwich panels: application to pyramidal truss cores, *International Journal of Solids and Structures* 41: 6249-6271. <http://dx.doi.org/10.1016/j.ijsolstr.2004.05.045>.
4. **Kim, H.; Kang, K.-J.; Joo, J.-H.** 2010. A zigzag-formed truss core and its mechanical performances, *Journal of Sandwich Structures and Materials* 12: 351-368.

- <http://dx.doi.org/10.1177/1099636209104519>.
5. **Neugebauer, R.; Lies, C.; Hohlfeld, J.; Hipke, T.** 2007. Adhesion in sandwiches with aluminum foam core, *Production Engineering Research and Development* 1: 271-278.
<http://dx.doi.org/10.1007/s11740-007-0046-4>.
 6. **Evans, G.A.; Hutchinson, W.J.; Ashby, F.M.** 1998. Cellular metals, *Current Opinion in Solid State & Materials Science* 3: 288-303.
 7. **Mukai, T.; Kanahashi, H.; Miyoshi, T.; Mabuchi, M.; Nieh, T.G.; Higashi, K.** 1999. Experimental study of energy absorption in a close-celled aluminum foam under dynamic loading, *Scripta Materialia* 40: 921-927.
 8. **Banhart, J.** 2000. Manufacturing routes for metallic foams, *JOM* 12: 22-27.
 9. **Sypeck, J.D.** 2005. Cellular truss core sandwich structures, *Applied Composite Materials* 12: 229-246.
<http://dx.doi.org/10.1007/s10443-005-1129-z>.
 10. **Xue, Z.; Hutchinson, W.J.** 2006. Crush dynamics of square honeycomb sandwich cores, *International Journal for Numerical Methods in Engineering* 65: 2221-2245.
<http://dx.doi.org/10.1007/s10443-005-1129-z>.
 11. **Zhou, J.; Deng, Z.; Liu, T.; Hou, X.** 2009. Elastic structural response of prismatic metal sandwich tubes to internal moving pressure loading, *International Journal of Solids and Structures* 46: 2354-2371.
<http://dx.doi.org/10.1016/j.ijsolstr.2009.01.017>.
 12. **Zhou, J.; Deng, Z.; Liu, T.; Hou, Z.** 2010. Optimal design of metallic sandwich tubes with prismatic cores to internal moving shock load, *Structural and Multidisciplinary Optimization* 41: 133-150.
<http://dx.doi.org/10.1007/s00158-009-0408-y>.
 13. **Liu, T.; Deng, Z.C.; Lu, T.J.** 2007. Bi-functional optimization of actively cooled, pressurized hollow sandwich cylinders with prismatic cores, *Journal of the Mechanics and Physics of Solids* 55: 2565-2602.
<http://dx.doi.org/10.1016/j.jmps.2007.04.007>.
 14. **Hutchinson, J.W.; He, M.Y.** 2000. Buckling of cylindrical sandwich shell with metal foam cores, *International Journal of Solids and Structures* 37: 6777-6794.
 15. **Zhou, J.; Deng, Z.; Xu, D.** 2011. Dynamic response of prismatic metallic sandwich tubes under combined internal shock pressure and thermal load, *Composite Structures* 94: 166-176.
<http://dx.doi.org/10.1016/j.compstruct.2011.07.004>.

A. Žiliukas, M. Kukis

GOFRUOTO KORĖTO SLĖGIO INDO STIPRUMO SKAITINIS IR EKSPERIMENTINIS TYRIMAS

Re z i u m ė

Straipsnyje nagrinėjamas korėto cilindro stiprumas ir nurodomi jo masės privalumai, palyginti su vientisos medžiagos cilindru. Pateikiami korėto cilindro stiprumo skaičiavimai baigtinių elementų metodu.

Skaičiavimuose nagrinėtas korėtas cilindras išbandytas natūrinėmis apkrovimo sąlygomis ir gauti eksperimentinių tyrimų duomenys. Skaitinio ir eksperimentinio tyrimų rezultatai gerai sutapo ir parodė, kad esant tam pačiam slėgiui korėto cilindro masė yra 1.42 karto mažesnė negu vientiso ir tai leidžia taupyti medžiagas, kurti lengvas konstrukcijas.

A. Žiliukas, M. Kukis

PRESSURE VESSEL WITH CORRUGATED CORE NUMERICAL AND EXPERIMENTAL ANALYSIS

S u m m a r y

The article examines the cylinder's core strength and indicates the advantages of its weight compared to the integral material cylinder. Numerical investigations of the finite element method applied to the strength calculation of a cylinder with a core are presented.

The cylinder with a core examined by the calculations was tested in the natural load conditions and the experimental data was obtained. The comparison of the numerical and experimental results has shown a good congruence. In the case of the same pressure, the results have shown that the cellular cylinder's mass is 1.42 times lesser than integral's and it allows to save the materials and to create light structures.

Keywords: cellular vessel, stress, displacements, finite elements method.

Received October 31, 2012

Accepted August 21, 2013