

On-line Partial Discharge Detection for High Voltage Rotating Machines Using Inductive Method

G. Dauksys^{1,2}, A. Jonaitis¹

¹*Department of Electric Power Systems, Kaunas University of Technology,
Studentų St. 48, LT-51367 Kaunas, Lithuania*

²*Faculty of Electromechanics, Kaunas Technical College,
Tvirtovės al. 35, LT-50155 Kaunas, Lithuania
gediminas.dauksys@gmail.com*

Abstract—The solid insulations of electrical equipment are perpetually affected by various duration overvoltages. Electric stress of insulation depends on its thickness and amplitude of applied voltage. The damaged solid insulation may also influence characteristic parameters of partial discharges. The characteristic parameters of solid insulation quality should be permanently evaluated.

Partial discharge monitoring provides reliable information necessary for basic maintenance of stator windings of motors and generators. Submitted paper deals with partial discharge measurements in stator windings during the increasing of applied voltage.

Index Terms—Insulation condition, partial discharges, work duration, internal discharges, overvoltage.

I. INTRODUCTION

Insulation of high voltage rotating electric machines changes its properties due to acting of various operating factors: vibrations, high temperatures, heating and cooling cycles, operating voltage, overvoltages, pulse and dynamic loading [1]. Influence of outdoor surroundings plays a valuable role at the deterioration of insulation, too, such as: moisture, chemical compounds, various types of radiations, impurities. Life time of insulation depends on intensity and duration of thermal, electrical and mechanical stresses.

The major factor which makes the greatest influence on the insulation's life time is temperature. Due to high temperatures, processes of thermal-oxidative destruction are present in high voltage insulation. These processes cause the decrease of mechanical strength, loss of elasticity and unlocking of fleet components, which is the reason for the creation of gas filled cavities in high voltage solid insulation [2].

Partial Discharge (PD), referred to as the discharge process, which takes place in the liquid or solid insulation defects [3].

Partial discharge can be caused by a strong electric field near the sharp electrode edges or occur at the weakest

insulation (dewy insulation or contaminated with impurities). Most dangerous partial discharges occur in liquid or solid insulation voids and gaseous micro-layer junctions and cracks, where the discharge processes occur at much weaker than the electric fields in liquid or solid insulation.

II. METHODS OF PARTIAL DISCHARGES MEASUREMENTS

Various methods can be used for partial discharges measurements in electric machines. Separate authors describe different methods of experimental research of PD. A review of different works regarding to PD measurements is presented below.

In order to generate the best evaluation of a machine's insulation condition a series of tests have been carried out upon coil samples using dummy slots [4]. Good coils were tested, then faults were introduced and recordings made of the associated discharge activity. This approach allowed tests to be carried out giving firsthand experimental results of the discharge associated with a certain fault type. The data generated from PD tests have proven useful in diagnosing faults with machines which have been tested in the field with recognisable PD characteristic.

The Acoustic Emission (AE) detection method for on-line hydrogenerator stator winding insulation has some advantages over electrical PD detection methods. The AE methods are immune to electromagnetic noise, which can greatly reduce the sensitivity of electrical methods, especially when, applied under field conditions. The sensitivity of AE methods does not vary with test object capacitance hence these methods are widely applied to large capacitors and other apparatus having large capacitance [5]. It is possible to estimated occurrence position of PD on the hydrogenerator stator windings that were composed of epoxy resin insulation material using several AE sensors. Authors carried out the experiment for the hydrogenerator which rated voltage and capacity were 11.0 kV and 20,700 kVA, respectively [5]. Additionally, the correlation of AE signals and off-line diagnosis were obtained by doing simultaneous twice measurements with off-line diagnosis for a 3 kV high voltage motor as a model test in detail. Fig. 3 shows positions of AE sensor setting on the outer frame of

stator iron for high voltage motor. An AE sensor with Resonance frequency 70 kHz was used. The intensity of AE signals was investigated in real time. It allowed to know the AE level of PD in the field instantly.

The next method of partial discharges measurement is PD monitoring using patch antenna. On-line PD monitoring system with higher sensitivity and low noise features was developed for rotating machines. The peculiarity of this method is the use of narrow band detection in GHz region [6]. The system is composed of an antenna, a specifically designed signal processing circuit and data acquisition equipment. The antenna is called „Patch antenna“ and its dimension is approximately 120x120 mm and is designed for detecting a specific narrow band frequency in GHz range. This type of antenna is very easy to install because the thin plate structure does not interfere other high voltage parts inside the rotating machine if installed on the inner wall of the machine housing. The antenna is connected to the amplifier adjusted for the frequency band of the antenna resulting in superior noise suppression. The sensitivity of the system was measured and confirmed to have a good linear correlation with conventional off-line q_{\max} value from several hundreds picocoulomb. This sensitivity is enough for on-line insulation monitoring for rotating machines because the low level PD activity during operation does not infer abnormality of the machines. The patch antenna has narrow band detection capability from 1.5 GHz to 2.0 GHz. Motors must be 6.6 kV rated voltage, 1–3 MW output power. The q_{\max} for the motors was measured by conventional capacitor coupling method during shutdown by applying the rated voltage to all the three phase power lines.

A novel high sensitivity differential current transformer (HSCT) is used as a sensor for monitoring insulation capacitance and dissipation factor of motors. To detect online PD of stator end-winding insulation in medium/high voltage AC motors [7]. Partial discharge couplers were used to measure PD during tests. A high sensitivity differential current transformer has been developed for online monitoring the health of ground-wall insulation through capacitance (C) and dissipation factor (DF) measurements. The motor insulation leakage current flowing from the winding to ground is equal to the difference between the currents in the line and neutral leads of a stator phase winding. The HSCT, which encircles both line and neutral leads of a stator phase winding, measures the insulation leakage current of that phase. HSCTs are installed in each phase of the motor to measure C and DF online. Three partial discharge couplers (1 nF each) with embedded radio frequency current transformer are installed, one on each phase, to monitor partial discharge activities online.

III. CHARACTERISTICS OF THE PARTIAL DISCHARGES

Partial discharges can be described by a number of different characteristics. Few of these characteristics are interrelated and few of them describe particular features of partial discharge phenomenon. Below a list of characteristics usually used for evaluation of PDs is presented.

The main parameter which defines PD in solid insulation is the apparent charge q , usually expressed in picocoulombs

(pC). Normally it must be about 10–50 pC. Dangerous level is reached when partial discharges are more than 1000 pC. At such high intensity of PDs an electrical arc may occur in the insulation, the increase of the temperature deteriorates insulating characteristics; the shifting dendrite may originate and cause the breakdown of the insulation.

PD pulse repetition rate n . It is the ratio between the total number of PD pulses recorded in a selected time interval and the duration of this time interval.

Pulse repetition frequency N is the number of partial discharge pulses per second, in the case of equidistant pulses.

PD phase angle Φ_i (in electrical degrees ($^\circ$)) and time t_i of occurrence of a i^{th} PD pulse can be calculated according to the (1)

$$\Phi_i = 360 \frac{t_i}{T}, \quad (1)$$

where t_i is the time measured between the preceding positive going transition of the test voltage through zero and the partial discharge pulse; T is the period of the test voltage.

The derived characteristics of partial discharges allow more comprehensive evaluation of analysed phenomenon.

The average discharge current I is the derived quantity of the sum of the absolute values of individual apparent charge magnitudes q_i during a chosen reference time interval T_r divided by this time interval

$$I = \frac{\sum_{i=1}^m |q_i|}{T_r}, \quad (2)$$

where I is the average discharge current; q_i is the apparent charge magnitude of the i^{th} discharge; T_r is the reference time interval; m is the number of sampled discharges.

The average discharge current is generally expressed in coulombs per second (C/s) or in amperes (A).

The quadratic rate D is the sum of the squares of the individual apparent charge magnitudes q_i during the chosen reference time interval T_r divided by this time interval

$$D = \frac{\sum_{i=1}^m q_i^2}{T_r}, \quad (3)$$

where D is the quadratic rate, generally expressed in square coulombs per second (C^2/s).

The discharge power P is the average pulse power fed into the terminals of the test object due to apparent charge magnitudes q_i during a chosen reference time interval T_r

$$P_{DI} = \frac{\sum_{i=1}^m |q_i \cdot u_i|}{T_r}, \quad (4)$$

where P_{DI} is the discharge power is generally expressed in watts (W); u_i is the instantaneous value of the test voltage at the instants of occurrence t_i of the individual apparent charge

magnitudes q_i .

About insulation condition we can know from the insulation useful life (τ_d). That it is the main practice parameter about solid insulation

$$\tau_d = \frac{R}{B_0 \cdot P_{DI}}, \quad (5)$$

where τ_d is the insulation useful life is generally expressed in months; R is the resource of the insulation; B_0 is the coefficient (the amount of gas when insulation material is influenced by 1 J PD energy).

Device insulation useful life depends on overvoltages, device loading, temperature of insulation and cooling.

The increase of PD reduces the operation time of insulation. The level of PD detected on start of motor exploitation is one of the main criteria of the safe operation time of insulation. The regular registration of PD parameters could help early to detect the troubles in the insulation and make corresponding prognosis for obligatory repair works.

IV. EXPERIMENTAL INVESTIGATION

The 6 kV 315 kW inductive electric motor was chosen for the investigation of PD processes in insulation. The motor is installed and working in the chemical factory and drives the water pump. The operation of the motor is continuous with constant load. The motor operates non-stop in time intervals from 6 to 10 months.

The experiment was performed in order to evaluate the level of PD in the solid insulation of the motor stator. The partial discharges were detected by the device LDP-5 (differential Lemke probe) which uses the inductive method of PD detection.

The experimental scheme consists of the capacitance sensor, the device LDP-5, the oscillograph and the laptop (Fig. 1). The measurements of PD were performed in one month interval. This allowed to evaluate the growth of PD intensity in the insulation over time.

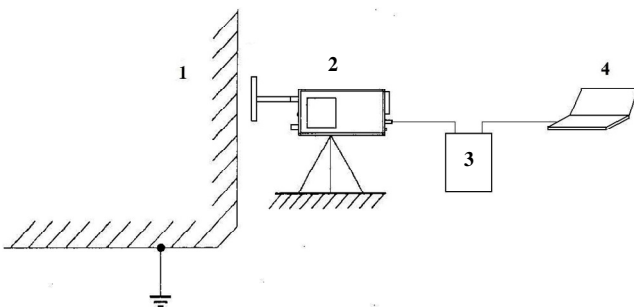

Fig. 1. Functional diagram of the experiment: 1 - stator of inductive motor; 3 - electronic oscillograph.; 2 - LDP-5 with capacitance sensor; 4 - laptop.

During the experiment, the voltage of PD in air gaps in the solid insulation and in gaps between the solid insulation and the imitational core of the stator was recorded.

The oscillogram of PD voltage during the beginning of the experiment is presented in Fig. 2. The maximum instantaneous value of the voltage was 22.1 mV. One cycle (20 ms) for the calculation of the partial discharge levels was chosen (time window 1–2 in Fig. 2). The comparison of PD

distribution over voltage phase angle is presented in Fig. 3. The biggest partial discharges occur when voltage sinusoid is at the maximum level. The phenomenon is observed at both positive and negative periods. Some of partial discharges were detected at the negative period when sinusoid intersects zero. The evaluated values of the apparent charge of PD are: maximum apparent charge $q_{\max} = 49.17$ pC, average apparent charge $q_{\text{average}} = 15.40$ pC. The biggest apparent charge was observed when voltage phase angle was in the interval of 60–100° and 190–240° (dotted line in Fig. 3).

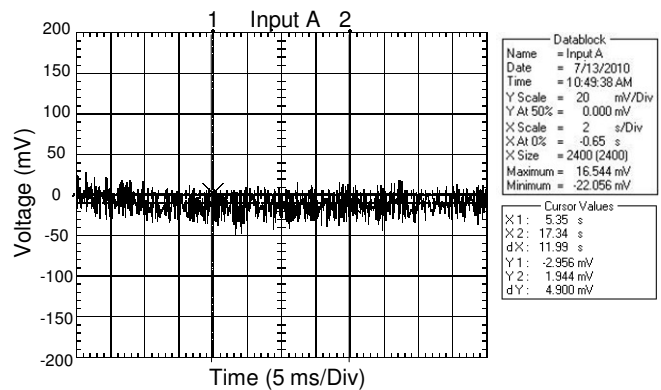

Fig. 2. Fragment of voltage oscillogram of the first experiment.

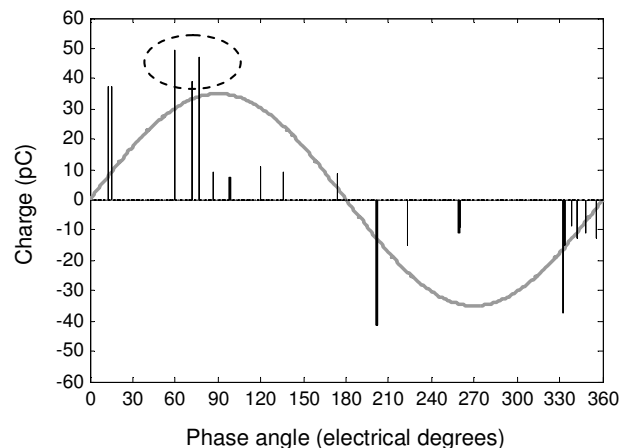

Fig. 3. Phase angle and partial discharges distribution in first experiment.

The voltage oscillogram recorded in the end of the experiment (one month later after the previously described measurements) is shown in Fig. 4. The magnitude of the measured voltage is higher comparing with previous measurements and indicates the increased intensity of partial discharges in the insulation. In this case, the measured maximum instantaneous value of the voltage was 96.0 mV.

The evaluated values of the apparent charge of PD are: maximum apparent charge $q_{\max} = 87.25$ pC and average apparent charge $q_{\text{average}} = 19.60$ pC. The biggest apparent charge was observed when voltage phase angle was in the interval of 60–150° and 270–330° (dotted lines in Fig. 5). The mostly common level of the apparent charge impulses was 40 pC.

The intensity of partial discharges increased in the stator solid insulation of the operating inductive motor during the experiment.

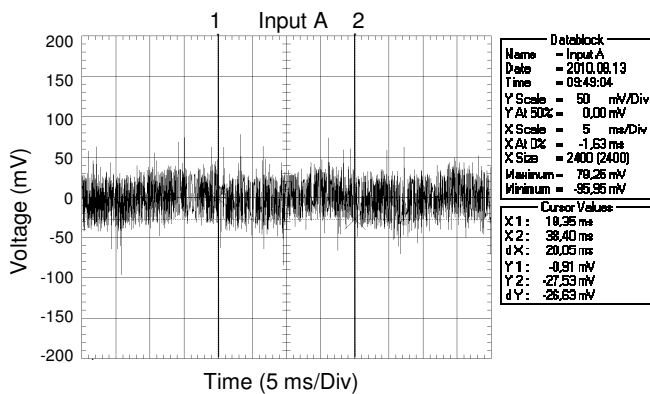

Fig. 4. Fragment of voltage oscillogram of the second experiment.

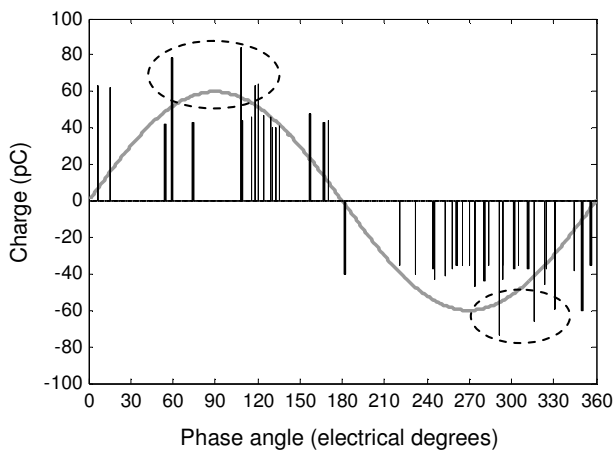

Fig. 5. Phase angle and partial discharges distribution in second experiment.

The results of these two experiments show that the apparent charge of PD, in one month, aroused by 2.91 % (29.08 pC). The renovation of the motor is obligatory when apparent charge of PD is bigger than 1000 pC [2]. Assuming that the growth of the PD intensity is linear, the permissible limit of partial discharges would be achieved in 33.8 months after the experiment (Fig. 6).

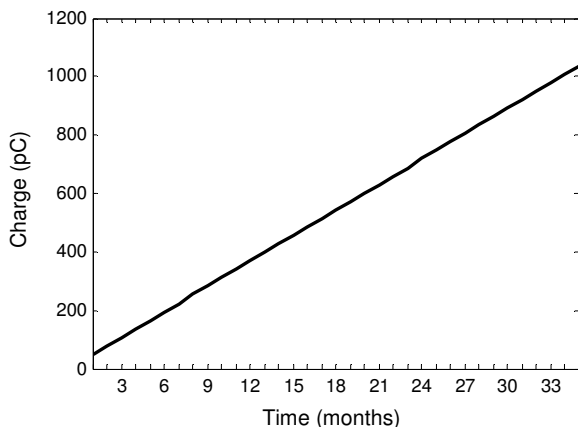

Fig. 6. The exploitation period of stator insulation evaluating the level of partial discharges.

The experiment was performed in summer, so temperature of insulation was the biggest according all year. The possible lower pump-house air temperature at winter time wasn't evaluated. So partial discharges aroused by 2.91 % can be

less. The prediction of permissible continuous operation of the motor does not evaluate bearing condition, only insulation

V. CONCLUSIONS

Partial discharges measurements performed in dependence of applied testing voltage seem to be very useful and progressive in the diagnostics of the state of stator insulation:

1. Analysis of the experimental data shows that the apparent charge of PD in the insulation of the investigated motor aroused by 2.91 % per month.
2. Evaluation of PDs intensity recommends to perform the solid insulation maintenance of the motor after 33.8 months. This time is longer than the period of the general scheduled maintenance which must be performed every 12–24 months according to the maintenance rules.
3. The measurements were performed in summer time and show the largest increase of PDs. The lower temperature in other seasons would cause lower increase of PDs and the required period of the maintenance could be even longer than estimated
4. The proposed method enables to reveal dangerous internal discharges, which usually are undetectable at the nominal values of voltage testing.

REFERENCES

- [1] P. Valatka, G. Daukšys, "Investigation of the Voltage Influence on Partial Discharge Characteristic Parameters in Solid Insulation", in *Proc. of the XX International Conference on Electromagnetic Disturbances (EMD 2010)*, Kaunas, 2010, pp. 155–158.
- [2] I. M. Bortnik, *High Voltage Engineering*, Moscow: Energoatomizdat, 1993.
- [3] J. Kurimsky, I. Kulcunova, R. Cimbala, "Partial Discharge Analysis for Insulation Systems of Electric Rotating Machines with Various Voltage Stress", *Acta Electrotechnica et Informatica*, vol. 8, no. 4, pp. 64–67, 2008.
- [4] P. Smeeton, A. Bousbaine, "Fault Diagnostic Testing using Partial Discharge Measurements on High Voltage Rotating Machines", in *Proc. of the 44th International Universities Power Engineering Conference (UPEC)*, Glasgow, 2009, pp. 1–5.
- [5] T. Tsuji, T. Kaneko, et al., "On-line Partial Discharge Detection for Water-Wheel Generator using Acoustic Emission Sensors", *IEE of Japan*, vol. 1 12-B, no. 4, pp. 13–19, 2002.
- [6] H. Muto, Y. Kaneda, H. Aoki, O. Hamamoto, "On-line PD Monitoring System for Rotating Machines using Narrow Band Detection of EM Wave in GHz Range", in *Proc. of International Conference on Condition Monitoring and Diagnosis (CMD 2008)*, Beijing, 2008, pp. 1093–1096. [Online]. Available: <http://dx.doi.org/10.1109/CMD.2008.4580473>
- [7] N. Prabhakar, Z. Pinjia, Q. Xiaoguang, "Online Detection of Endwinding Contamination in Industrial Motors", in *Proc. of 2011 Electrical Insulation Conference (EIC 2011)*, Annapolis, 2011, pp. 265–270.