

# Influence of stainless steel circular pipes welding methods and parameters to the process accuracy and productivity

E. Biekša\*, R. Mankutė\*\*, A. Bargelis\*\*\*

\*Kaunas University of Technology, Kęstučio 27, 44312 Kaunas, Lithuania, E-mail: egidijus.bieksa@stud.ktu.lt

\*\*Kaunas University of Technology, Kęstučio 27, 44312 Kaunas, Lithuania, E-mail: rasa.mankute@ktu.lt

\*\*\*Kaunas University of Technology, Kęstučio 27, 44312 Kaunas, Lithuania, E-mail: algirdas.bargelis@ktu.lt

crossref <http://dx.doi.org/10.5755/j01.mech.19.2.4161>

## 1. Introduction

Many industries are frequently use stainless steel tubular constructions, which are manufactured using welding. While welding tube structures is especially important to keep the elements in right dimensions, in particular axial and angular parameters, which are strongly influenced by welding residual stresses. They arise due to different heating and cooling conditions of the joint components and adjacent zones of the welded parts. That is the main reason of a deformation the joined parts.

The stainless steel circular pipes welding is one of different available methods often applied in industry tungsten inert gas (TIG) and (metal inert gas) MIG are two types of often use welding methods amongst the few choices available for this aim [1]. Laser welding techniques [2] widely is used for thin parts or tubes and light materials magnesium and aluminium. Welding parameters must be controlled carefully seeking process quality and productivity. This is related with welding process energy consumption and travel speed which should be kept uniform and as high as possible [3]. Another way to increase productivity is to enhance robotic welding [4]. It shows how the product modularization can reduce the total number of parts and simplify of a product's structure. This improved the robot welding giving benefits of manufacturing because productivity and quality are increased. Welding process accuracy influences on product quality when reworks of non-quality products are avoided [5]. The destructive and non-destructive techniques to evaluate the weld quality in modern welding production are used [6]. This research examines destructive methods; also some attention has been paid to find future trends in the development of new welding evaluation approaches. The review of non-destructive methods and techniques used to evaluate the weld quality are presented [7]. Some attention has been paid to look future trends in the development of welding evaluation approaches. This study provides a good foundation for learning and creates awareness among the metal industries to evaluate their work accuracy, quality and productivity in the field of welding.

Welding process accuracy and quality is analysed in research papers through residual stress and fatigue strength during past years. Fatigue strength of different notch classes regarding post weld treatment methods and repair techniques in consideration of size effect is examined [8]. Welded tubular steel constructions must be checked by the critical aspect in the design of trussed-girder bridges and other products with the local hot spot stresses at the pipe intersection. The joint properties and

their improvement in thin walled circular pipe friction welded joint for an AISI 310S austenitic stainless steel are considered [8]. The welded specimen with a pipe thickness of 1.50 mm was made at a friction welding machine with pressure of 120 MPa and the joining could be successfully achieved and that had 100% efficiency with the base metal fracture. However, the joining became difficult with decreasing pipe thickness, and it was not successful at a pipe thickness of 0.50 mm [9]. It was found that when pressure in friction welding machine is decreased to 30 MPa, the joining could be successfully achieved, although that did not have 100% efficiency. Stress corrosion cracking (SCC) in 316L stainless steel recirculation pipes have been observed near butt welding joints [10]. These SCC in 316L stainless steel grow near the welding zone mainly because of the high tensile residual stress caused by welding. The distribution and scatter of residual stress were measured by stress relief and X-ray diffraction methods. The effect of welding parameters on residual stress distribution have been evaluated through welding simulations based on finite-element analysis using three dimensional and axisymmetric models.

The objective of this research is to examine stainless steel circular pipes welding parameters on the process accuracy and productivity. The interfacing of different welding methods on accuracy and productivity were investigated applying a different thickness of pipe walls. Experimental and analytical studies have shown stainless steel pipe welding deformations. Manual and automatic method of TIG was used in analysis of welded pipe shrinkage and samples' axis deviation. Recommendations for keeping stainless steel pipes axial position accuracy during welding and available productivity variations are given.

## 2. Research methodology

In modern manufacturing environment the competitive criteria are products and processes quality, cost and productivity. Welding processes are urgent to use secure methods achieving product strength, reliability and accuracy with competitive prices on the market. The welding operations productivity plays the main influence to be competitive and winning orders. Analysis of Lithuanian companies involved in welding process business exposed the main interferences of work productivity, which are: under accuracy, bad welding seams' quality, rework of welded products, low level use of robotic in welding processes and low skill of welding employees.

Numerous publications analysed in introduction of this paper deal with problems mentioned above. Ana-

lysed research, unfortunately, is related with separated problems of welding processes, as strength, residual stresses and parameters of different welding methods. The aim of this paper is to look interfacing of different welding parameters to the final result of welded product and applied process to be competitive in a market. The framework of carried out research is presented in the Fig.1. First stage is analysis of every product's welding parts and sub-assemblies looking for errors and bad manufacturability. If available, some product's design exchange or modification must be made. Second stage is appropriate welding process and method selection that would be achieved required accuracy and other parameters. Chosen welding process and method by productivity index is checked at the early process development stage. Productivity index in this methodology is defined as a ratio between created value and incurred cost for it. If productivity index is not satisfied, the welding process has to be re-developed. The final stage is divided for product total testing and delivering to customer. Applying the developed framework the strategy 'make or buy' has to be considered looking the cheapest possibilities of potential partners, because they often can propose better alternative than itself producer.

For realization of developed framework three welding methods have been used:

- 1) manual TIG;
- 2) automatic TIG;
- 3) automatic plasma + TIG.

The parameters of mentioned three welding methods and dimensions of tested pipes are presented in Table 1. The quality of welding seams has been checked applying methodology described and used in [6, 7]. The calculation of welding time  $T$  in  $s$  has been carried out using company's statistical data and timing procedure:

$$T = T_{set} / p + T_{grip} + T_w, \tag{1}$$

where  $T_{set}$  is set up time of a welding operation in  $s$ ;  $T_{grip}$  is gripping time of parts in welding operation,  $s$ ;  $p$  is the batch size;  $T_w$  is welding time, in  $s$ .

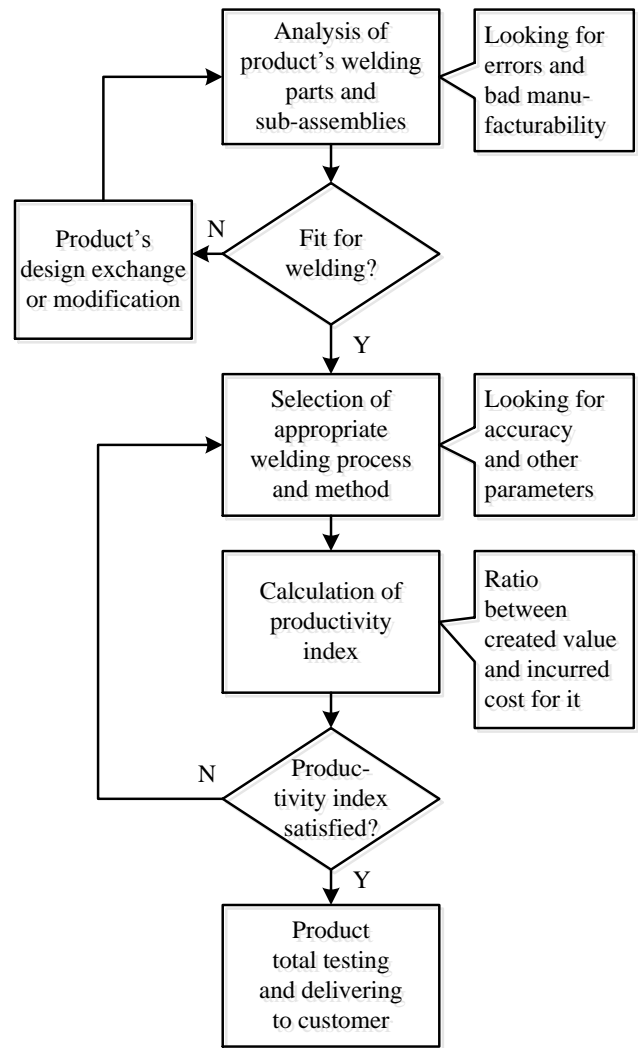

Fig. 1 Framework of interacting research the welding parameters, accuracy and productivity

Table 1

Welding processes methods and main parameters

Welding method	Process code	Current power strength, A	Voltage, V	Number of welding passes	Pipe wall thickness, mm	External diameter, mm	Welding time, s	Total welding time, s
Manual TIG	141	60-65 70-75	8-9	2	3.05	Ø73.1	344	386
	141	65-70 75-80 75-80	8-11	3	5.16	Ø73.1	517	562
	141	130-150 135-160 160-180 160-180	10-15	4	8.18	Ø219.1	2064	2157
Automatic TIG	141	75-80 75-80	12-14	2	3.05	Ø73.1	230	348
Automatic Plazma +TIG	15	210	30	3	5.16	Ø73.1	264	383
	141	215-230	13-15					
	141	215-230	13-15					
	15	240	34	4	8.18	Ø219.1	1116	1603
	141	250-270	16-18					
	141	260-280 280-300	16-18					

$T_{set}$  and  $T_{grip}$  are defined from companies' statistical data, while  $T_w$  is calculated applying timing charts.  $T$  in final stage is multiplied by overheads coefficient  $k = 1.1 - 1.25$ . The incurred welding cost is defined as follows:

$$C_w = W + T \times A / 3600, \quad (2)$$

where  $W$  is cost of welding materials, EUR;  $A$  is welding operation cost in EUR/h.

$$A = \sum_{l=1}^s L_l, \quad (3)$$

where  $L$  is cost portion of technological operation in EUR/h;  $l$  is number of variables, i.e. machine and space cost, machine maintenance cost, internal logistic and auxiliary materials cost.

Analysing the statistical data and manual calculation methodology in sheet metalworking companies applying welding operations, the definition of value  $A$  has been done.

### 3. Experiments' results discussion

Twenty pieces of circular  $\text{Ø}73$  mm diameter pipe from the standard austenitic stainless steel AISI 304L (international marking: EN 1.4307) were chosen for the experiment. Length  $L = 150 \pm 0.05$  mm and thickness  $e = 3.05$  mm. The chemical composition of AISI 304L is: C 0.02; N 0.04; Cr 18.2; Ni 10.1. Ten pieces of tube were welded manually and ten pieces by automatic TIG method.

While welding pipes manually using TIG method tube edges were prepared making  $30^\circ$  angle beveling (Fig. 2, a); while preparing for manual welding pipes were tack welded in four points positioning  $90^\circ$  and keeping 2 mm gap between the retaining rods, which ensures a better root penetration weld. In the order to reduce the welding deformations  $\text{Ø}73$  mm diameter pipes were welded dividing the seam into four parts along the perimeter and welding contra sides first (Fig. 3), then the same procedure repeated on the second seam.

Electrode, the arc and the environment around the melted metal bath protected from the atmosphere by argon Ar 99, 99% inert gas, which fed into the welding zone 8-10 l/min., also to keep good quality and geometry of welding seam argon Ar 99, 99% inert gas is supplied inside pipe 10-12 l/min. Filler metal rods are fed to the front of the melted metal bath [11].

The Automatic TIG pipe welding method for a special  $\text{Ø}73$  mm diameter pipe does not requires edge preparation (Fig. 2, b). The pipes at the beginning of the process are tack welded in four points every  $90^\circ$  degrees around the pipe circumference without gap and without the additive wire rods. Welding seam is formed continuously in two layers rotating pipe in electric spinner support. Electrode, arc, pipe inside, and melted metal bath are protected from the environment by gas, which is frequently used in stainless steel TIG welding process. Compared to pure argon Varigon H5 gas improves weld ability and welding speed.

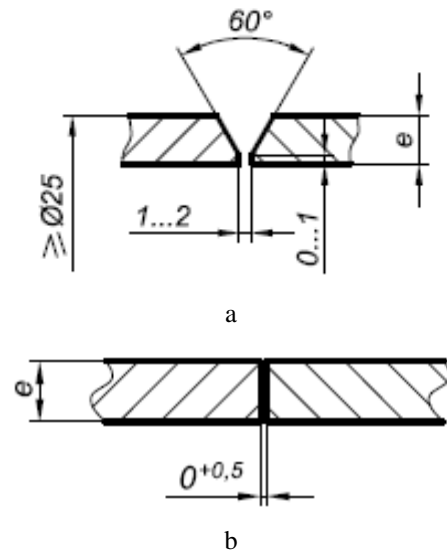

Fig. 2 Welding edge preparation: a) for manual welding; b) for automatic welding

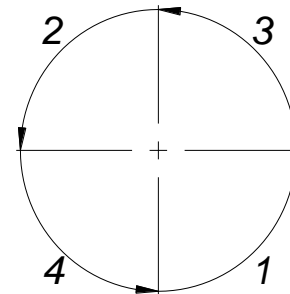

Fig. 3 Welding order in manual procedure

To determine the deformations occurred during welding, after each weld both for manual and automatic welding, length of samples was measured using altimeter while hot and at the room temperature. Length of welded pipes samples is given in the Table 2.

Analysed data in the Table 1 shows that the manually welded samples length after first seam and after cooling to room temperature deformations are varied from 3.15 mm to 3.55 mm and after welding a second seam and cooling the change of a total length varied from 3.75 mm to 4.25 mm. Automatically welded samples length after first seam and first cooling to room temperature deformations are changed from 0.05 mm to 0.35 mm and after welding a second seam and cooling change of the total length varied from 0.40 mm to 0.95 mm. It can be seen clearly that during automatic welding sample length deformations are bigger than the deformations after manual welding. This is explained by the fact that during manual welding to ensure seam quality was used edge preparations with  $30^\circ$  angle chamfer and samples were welded with the 2 mm gap. Length deformation also affected by uneven seam welding speed, which is determined by human factors. Another reason is that automatic welding goes in series from the first point at the process beginning to the same point at the process finishing. The welding process has been carried out from the bottom upward.

General information of considered welding methods

Manual welding						Automatic welding				
No.	Sample length after tack welding, mm	Length after first seam, mm		Length after second seam, mm		Sample length after tack welding, mm	Length after first seam, mm		Length after second seam, mm	
		Hot	Cold	Hot	Cold		Hot	Cold	Hot	Cold
1.	301.90	299.05	298.65	298.60	298.15	300.05	300.10	299.95	300.00	299.65
2.	302.10	299.30	298.95	298.70	298.20	300.05	300.15	299.85	299.75	299.15
3.	301.85	299.00	298.55	298.35	297.95	300.10	300.35	300.05	300.00	299.15
4.	301.85	298.95	298.40	298.15	297.80	300.00	300.05	299.65	299.65	299.30
5.	302.05	299.15	298.65	298.40	298.00	300.05	300.15	299.80	299.85	299.45
6.	301.95	299.00	298.75	298.55	297.95	300.10	300.10	299.90	299.85	299.55
7.	301.90	298.90	298.35	298.05	297.75	300.00	300.05	299.75	299.75	299.35
8.	302.00	299.05	298.65	298.35	297.90	300.10	300.10	299.85	299.90	299.40
9.	302.05	299.25	298.70	298.25	297.80	300.00	300.05	299.70	299.80	299.45
10.	301.90	298.85	298.35	298.00	297.65	300.10	300.10	299.85	299.85	299.50

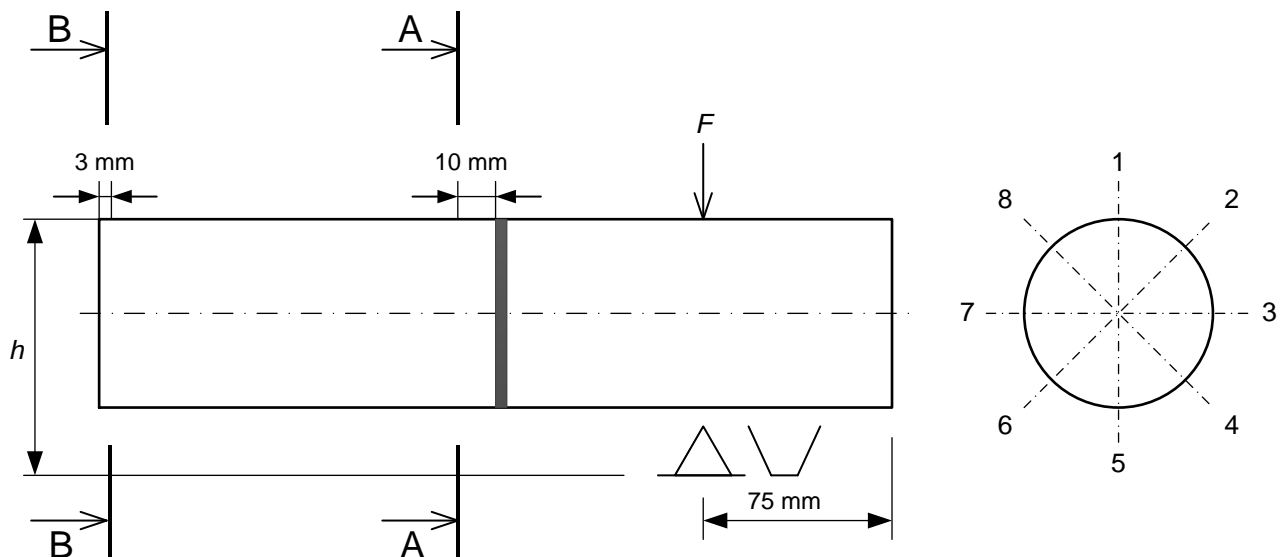

Fig. 4 Principal scheme of basing and measuring welded samples

While welding pipe structures is especially important to keep the dimensions of the drawings, axial positions and angular parameters. During the experiment to measure axial deviations measuring machine “ROMER SIGMA- 2022” was used. Measuring prism, presser and measuring machine table were used for samples basing and measuring. Fig. 4 shows the principal scheme of a measuring.

For the evaluation of axial deviations welded cylindrical surface is divided into eight parts. In the measuring device one end is based in the prism and pressed by constant force. Measuring machine head measures distances from the base surface (measuring machines table) in two sections A-A and B-B in each of the eight points. To measure the distances from cylindrical surface to the base surface of measuring machines in all eight points sample must be rotated about the axis 45° degrees.

It was measured ten manually welded samples, and ten automatically welded samples. Distances from a cylindrical surface to the measuring machines base surface

were measured. After the analysis of the measurements results has been found samples' number with the most axial deformations.

Difference in distances from the cylindrical surface to the base surface in sections A-A and B-B (Table 3, variant W1) shows the deviation from parallel of the base surface. A positive difference generates leaning down from the sample axis, the negative difference generates leaning from the top of the sample axis.

For manual welded sample most axial deviations were noticed at second and sixth points. The biggest positive difference at sixth point means that sample axis is leaning down. To avoid this deformation at sixth point we must put determined heat quantity in this position.

For straightening of the sample using the TIG welding machine at the sixths point has been put heat in 10 mm long zone. After cooling the sample to room temperature, it was measured the distance to base surface in sections A-A, and B-B in each of the eight points. The difference in distances is presented in Table 3, variant W2.

Differences in distances from the cylindrical surface to the base surface in sections A-A and B-B

Points	Manual welding		
	Welding variants		
	W1	W2	W3
P1	-0.71	-0.39	-0.16
P2	-0.83	-0.64	-0.38
P3	-0.62	-0.14	-0.13
P4	-0.05	0.19	0.04
P5	0.35	0.18	0.18
P6	0.58	0.39	0.19
P7	0.49	0.29	0.16
P8	0.14	0.16	0.15

Points	Automatic welding		
	Welding variants		
	W1	W2	W3
P1	0.46	0.30	0.23
P2	-0.46	-0.37	-0.31
P3	-1.02	-0.88	-0.49
P4	-1.2	-0.87	-0.47
P5	-0.48	-0.12	-0.12
P6	0.62	0.59	0.39
P7	1.11	1.03	0.57
P8	1.19	1.07	0.60

Welding variants: W1 – primary welding; W2 – welding after 1st heating; W3 – welding after 2nd heating.

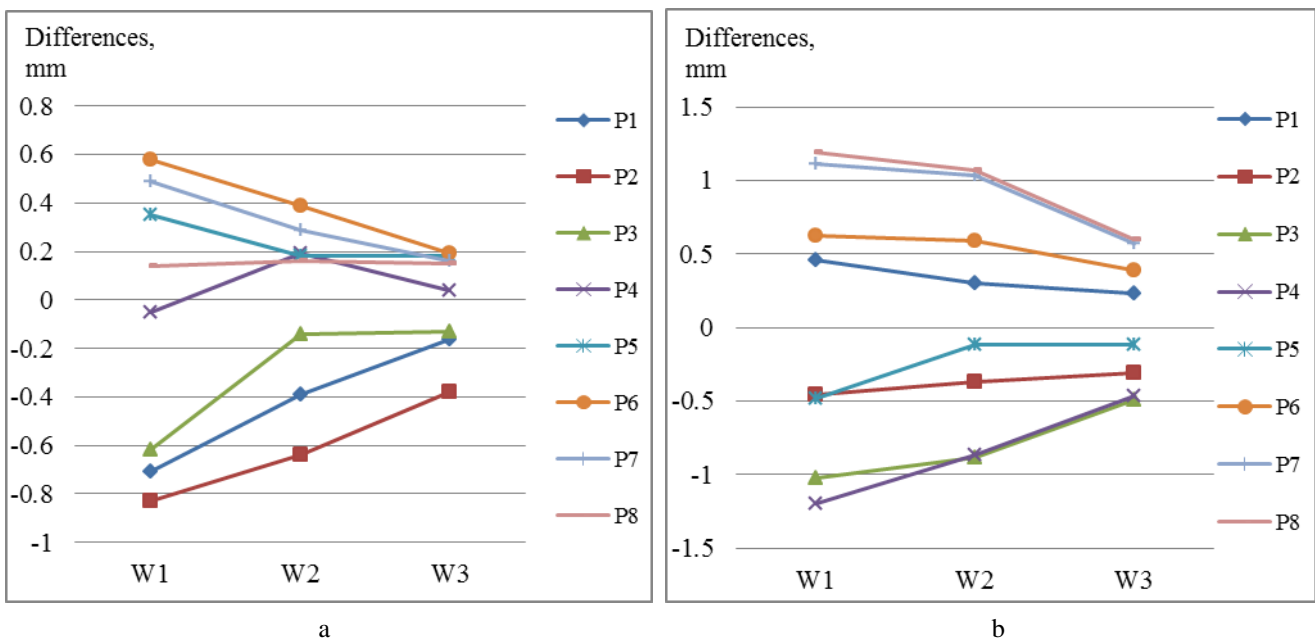

Fig. 5 The distribution of differences for each welding variant: a) manual welding; b) automatic welding

After the analysis of the measurements of manual welding results, it can be seen that at the second and sixth points still have the largest deviations from the parallel of the base surface. Therefore, one more time, at the sixth point heat was put in 10 mm long zone. After sample cooling to the room temperature, distance was measured to the base surface in sections A-A, and B-B in each of the eight points. The difference of these measurements is presented in Table 3, variant W3. The distribution of differences for each welding variant is presented in Fig. 5.

After the analysing the results data in Table 3 and Fig. 5 it can be concluded that the difference in distances from the cylindrical surface to the base surface in sections A-A and B-B is decreasing then putting determined heat quantity in a certain area of the welding seam. This means that samples' axial deviation is decreasing, and the sample straitens.

The measurements of automatically welded sample show the largest deviations from the parallel of the base surface at the fourth and eighth points. The biggest positive difference at eighth point means that sample axis is leaning down. To avoid this deformation at this point must be put a determined heat quantity in this position. For

straightening of the sample, using the TIG welding machine, at the eighth point the heating was put in 15 mm long zone. The automatic welding positive difference (1.19 mm) is larger than the largest positive difference of the manual welding (0.8 mm). So the bigger determined heat quantity (instead of 10 mm was heated 15 mm length zone). The heating of welded samples by TIG welding device with electrical power strength 75A and 8-9.1 V voltage in all used cases has been carried out. After cooling the sample to room temperature, was measured distance to base surface in sections A-A and B-B in each of the eight points. After the analysis of the measurements of automatic welding results, it can be seen that at the fourth and eighth points still have the largest deviations from the parallel of the base surface. Therefore, one more time, at the eighth point the heat put in 20 mm long zone. After cooling the sample to room temperature, it was measured distance to base surface in sections A-A, and B-B in each of the eight points. After the analysing the results data in Table 3 and Fig. 5 it can be seen that the sample straitens like in the manual welding case. Conclusion can be made, that for straightening welded pipes samples determined heat quantity in a certain area of the welding seam has to be put. The

heating quantity for both welding cases is defined experimentally.

The welding process productivity with welding speed directly is related. The appropriate tests finding an optimal welding speed have been used. These tests are bonded with welding method, variant and type, power strength and voltage, also pipes dimensions. After numerous occasions changing and combining above-mentioned parameters the optimal welding speed and process manufacturing time has been found (Table 1). Manufacturing time is a main constituent influencing to the welding process in current cost seeking the higher productivity index.

#### 4. Implementation and further research

The developed framework and methodology seeking welding process accuracy and productivity is implemented in Lithuanian industry. The implementation results in some companies have shown that the developed methodology is able to create an optimal welding process in virtual environment and to check incurred cost  $C_w$  (Eq. 2) of its realization. Majority of companies, unfortunately, higher productivity index  $I$  seek only decreasing  $C_w$ :

$$I = V/C_w, \quad (4)$$

where  $V$  is created value of product and process design in EUR.

Such way, however, is not best decision because created higher value  $V$  [12] in many cases of product and process design can increase index  $I$  much more. This problem becomes very important to Lithuanian industry because majority of its manufacturing companies (till 80%) make only parts and components without engineering and design. As product's life cycle shows the additional value of new product and process at the early design stage is created. Many social and domain factors influence to employees creativity and work motivation getting better experience and cleverness of innovative ideas generation and implementation in design process. It often requires changing the former order of organization activity preparing and sharing the information for the integrated product and process design. Some times it causes the complaints of the employees in an organization. There are many methods and possibilities how to solve mentioned problems: getting consultations from social and domain experts, implementing long life learning (LLL) methods in organization and searching chances for better corporate social responsibility (CSR) to employees.

It is planned in further research activity to develop an interface of creativity improvement in general framework of innovative product and process design. The appropriate methodology has to be foreseen involving and implementing an Internet technology and various web sites employing knowledge base (KB) and intelligent methods in manufacturing engineering and new products design. The value engineering method is one of more important fields in developed methodology. It includes the value estimating and creating chapters both for total product and process and their separate parts and components.

#### 5. Conclusions

1. After the analysis of welded pipe samples, it

can be seen that during automatic welding length deformation is smaller than the length deformation after manual welding. This can be explained by the fact that during manual welding to ensure seam quality it was used the pipe edge preparation with 30° angle chamfer and samples were welded with the 2 mm gap. Automatic welding does not require any gaps between pipes. Length deformation during manual welding also affected by uneven seam welding speed, which is influenced by human factors.

2. After the analyzing the sample axial deviations it is determined, that deviations after TIG automatic welding are bigger till 0.2 mm then after manual welding.

3. Both automatically and manually welded samples after putting determined heat quantity in a certain area of the welding seam straightening simultaneously.

4. The optimal welding speed has been found experimentally changing welding method and type, power strength and voltage for higher productivity index.

#### Acknowledgement

This research was partially supported by EC project grant agreement No 2007 – 1990 / 001 “Inter countries research for manufacturing advancement (IRMA)” in period from 01. 01. 2008 to 31. 12. 2009.

#### References

1. **Fahrenwaldt, H.; Schuler, V.** 2006. Know-How Welding Technology: Materials, Processes, Manufacturing. – DVS Verlag.
2. **Cao, X.; Jahazi, M.; Immagireon, J.; Wallace, W.** 2006. A review of laser welding techniques for magnesium alloys, *Journal of Materials Processing Technology* 171(2): 188-204. <http://dx.doi.org/10.1016/j.jmatprotec.2005.06.068>.
3. **Kahraman, N.** 2007. The influence of welding parameters on the joint strength of resistance spot-welded titanium sheets, *Materials & Design* 28(2): 420-427.
4. **Hiltunen, E.; Martikainen, J.** 2012. Modularization of aluminium boat's hull to enhance robotic welding, *Proceedings of 17-th Int. Conf. Mechanika 2012*, Kaunas University of Technology, April 7-th – 8-th, 77-81. <http://dx.doi.org/10.1016/j.matdes.2005.09.010>.
5. **Gerbeaux, H.; Piette, M.; Renault, J-P.** 1988. Deformations and Stresses in Welding, Paris: Publications de la Soudure Autogene, 108 p. (in French). <http://dx.doi.org/10.1002/nme.1620250223>.
6. **Kah, P.; Martikainen, J.; Layus, P.** 2011. Methods of evaluating weld quality in modern production (Part 1), *Proceedings of 16-th Int. Conf. “Mechanika-2011”*, April 7-8, Kaunas University of Technology, Lithuania, 164-169.
7. **Kah, P.; Martikainen, J.; Pirinen, M.** 2011. Methods of evaluating weld quality in modern production (Part 2), *Proceedings of 16-th Int. Conf. “Mechanika-2011”*, April 7-8, Kaunas University of Technology, Lithuania, 170-175.
8. **Bucak, O.; Lorenz, J.** 2011. Fatigue strength of different notch classes regarding post weld treatment methods and repair techniques in consideration of size effect, *Stahlbau*, 80(8): 608-618. <http://dx.doi.org/10.1002/stab.2011011462>.
9. **Kimura, M.; Ichihara, A.; Kusaka, M. et al.** 2012.

Joint properties and their improvement of AISI 310S austenitic stainless steel thin walled circular pipe friction welded joint, *Materials & Design* 38: 38-46. <http://dx.doi.org/10.1016/j.matdes.2012.02.006>.

10. **Katsuyama, J.; Tobita, T.; Itoh, H. et al.** 2012. Effect of welding conditions on residual stress and stress corrosion cracking behaviour at butt-welding joints of stainless steel pipes, *Journal of pressure vessel technology-transactions of the ASME* 134(2): 82-93.
11. **Biekša, E.; Krančiukas, R.** 2010. Quality analysis of stainless steel welded joints, *Proceedings of 15-th Int. Conf. "Mechanika-2010"*, April 8-9, Kaunas University of Technology, Lithuania, 70-74.
12. **Fowler, T.C.** 1990. *Value Analysis in Design*, New York: Van Nostrand Reinhold, p. 302.

E. Biekša, R. Mankutė, A. Bargelis

#### NERŪDIJANČIOJO PLIENO APVALIŲ VAMZDŽIŲ VIRINIMO METODŲ IR PARAMETRŲ ĮTAKA PROCESO TIKSLUMUI IR NAŠUMUI

#### R e z i u m ė

Straipsnyje nagrinėjami apvalių vamzdžių iš nerūdijančiojo plieno AISI 304L automatinio ir rankinio TIG virinimo metodai ir jų režimų įtaka proceso tikslumui ir našumui. Aprašoma vamzdžių rankinio siūlių suvirinimo seka. Analizuojamos bandinių deformacijos po automatinio ir rankinio virinimo, ir nustatomas ašinis nuokrypis. Pateikiamos bazavimo ir matavimų principinės schemos ir matavimų rezultatų analizė. Tyrimas pagrįstas eksperimentų rezultatais ir matavimais, siekiant panaikinti ašinį nuokrypį virinant plieno vamzdžius rankiniu ir automatinio būdu. Eksperimentiškai nustatytas virinimo greitis ir kiti parametrai, leidžiantys pasiekti geriausią našumo indeksą ir virinimo kokybę. Toliau moksliniame darbe bus tiriamos galimybės, kaip padidinti našumo indeksą, didinant kuriamo gaminio ir jo gamybos proceso vertę.

E. Biekša, R. Mankutė, A. Bargelis

#### INFLUENCE OF STAINLESS STEEL CIRCULAR PIPES WELDING METHODS AND PARAMETERS TO THE PROCESS ACCURACY AND PRODUCTIVITY

#### S u m m a r y

This article describes the interacting of AISI 304L stainless steel circular pipes automatic and manual TIG welding method and its parameters to the process accuracy and productivity. Pipe edge preparation described applying seam sequence for manual welding. Length of samples deformation is analyzed and their axial deviation after automatic and manual welding is determined. Basing and measurement principal schemes are presented. The results of measurements are systematized applying appropriate tables with presenting the results analysis. The research is based on experimental results and measurements deleting axial deviation of welded pipes after manual and automatic welding. Looking of best productivity index and welding quality the optimal welding speed and other parameters have been defined experimentally. Further research discusses the possibilities of improvement the productivity index increasing created product and process value.

**Keywords:** welding methods, circular pipes, stainless steel, parameters, accuracy, productivity.

Received April 06, 2012

Accepted April 08, 2013