

Diagnosics of construction defects in a building by using time-frequency analysis

V. Volkovas*, K. Petkevičius**, M. Eidukevičiūtė***, T.C. Akinci****

*Kaunas University of Technology, Technological Systems Diagnostics Institute, Kaunas, Lithuania, E-mail: tsdi@ktu.lt

**Kaunas University of Technology, Technological Systems Diagnostics Institute, Lithuania,
E-mail: kazimieras.petkevicius@ktu.lt

***Kaunas University of Technology, Technological Systems Diagnostics Institute, Lithuania, E-mail: meiduk@ktu.lt

****Kirkklareli University, Engineering Faculty, Department of Electrical & Electronics Engineering, Kirkklareli, Turkey,
E-mail: cetinakinci@hotmail.com

crossref <http://dx.doi.org/10.5755/j01.mech.18.4.2340>

1. Introduction

In many countries, the sudden collapse of the buildings has started to attract the attention of scientists. This research project could be a prototype for examining the structures of degradation. In this research, STATIMON (2010-2011) developed under the project [1, 2]. Similar accidents in the world and in Lithuania in recent years have increased the interest in the topic. Deformation structures, and research on this subject, can be analyzed by different mathematical methods [3]. This is a different mathematical analysis, important findings of the investigation of causes of damage in buildings are important to detect. A reliable evaluation of structural integrity becomes especially important at design, manufacture and service stages in objects of increased risk [1-3].

The analysis of standard structures and estimation of their functionality for a resource period usually are performed by regulations and norms, which are based on the huge theoretical and practical experience [4-6]. These regulations and norms however cannot be easily applied to the items of unique structure without additional detailed and comprehensive analysis [7, 8]. This is why at present it is allocated to work of development and improvement of structure strength prediction methodologies and technologies. Such activity takes place in different areas such as civil engineering, transportation, power industry and others [9, 10].

The traditional method of processing signals from transducers has been in the time domain using digital or analog methods. With the advent of the efficient computation scheme of the Fast Fourier Transform (FFT), processing in the frequency domain has become a practical reality. The frequency domain not only provides a viable alternative to time domain methods, but permits the solution of problems that involve frequency dependent parameters [11].

Structural deterioration in buildings can be reduced during the maintenance. Structural defects can be detected with the aid of a monitoring system in buildings. Deterioration factors for developing technological methods can be examined using the buildings [9-12]. This study, in particular distortion that may occurring buildings, emphasizes the mathematical analysis. In this study, the analysis of deformations in buildings is presented as a method of using signal processing techniques. Data obtained from experiments were analyzed by Short Time Fourier Trans-

form (STFT).

2. Static models of a building structure

Reliable prediction of static structural response is sensitive to all structural and analytical parameters. Conclusions on stress-strain states of structures can precisely match the reality, when structural parameters, loads, damages, deformations and their causes are identified correctly. The mathematical models of all processes taking place in a real structure should be well prepared and properly applied to foreseen structure monitoring procedures and measures. Geometrical form of structural elements can be very complex and different. Its precise reproduction in a numerical model sometimes can require very detailed meshing. It significantly increases the solved task and extends duration of their solution. Numerical models should be as simple as possible, however those should accurately enough reflect the simulated object. Preparation of it is difficult due to numerous parameters and settings required to define. For instance, loads and material properties are random values and their estimations should be defined by characteristics of probability distributions. Consequently, structural integrity analysis results are also random values; their probability distributions characterize probability of accident risk.

In numerical solutions, just as in analytical, some irregular's forms, which do not strong impact on results, better be avoided and simplified as rods, panels, shells, and solids.

For the analysis of the simplified buildings a model of floor structure was developed with included defects, the influence of which was estimated by measuring parameters of a corresponding physical model: deflections and strains occurring due to effect of static and dynamic loads. The floor structure is built using panels and columns. Their dimensions were selected according to assumed scale factors for suitable measured values of deflection, strains and frequencies [1]. Dimension of the flooring model are presented Fig. 1.

Floors and columns are made of construction steel with elasticity modulus $E = 200$ GPa, Poisson ratio $\nu = 0.3$, density $\rho = 7800$ kg/m³. The loading of the structure is realized with ceramic bricks, which dimensions are $65 \times 250 \times 120$ mm, and total weight of unit brick 4.2 kg. A single layer of bricks results a regular pressure of 5.4 kPa.

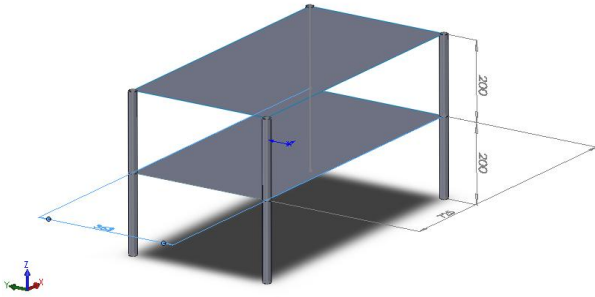

Fig. 1 Flooring structure model

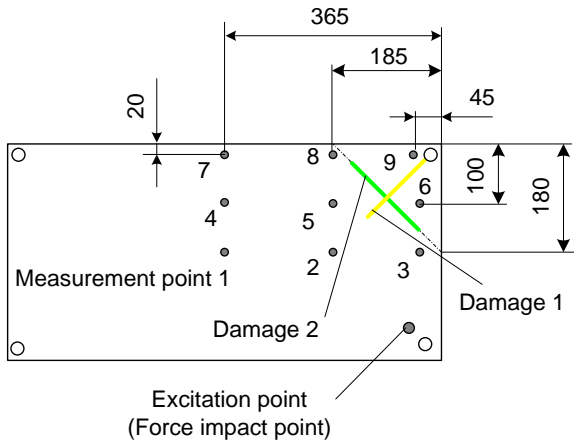

Fig. 2 Position of the defects and measurement points on the floor

3. FEM modeling of the building structure

The flooring structure stress and strain states were calculated using finite element models created in Solid Works Simulation system. The floors were meshed by triangle elements, whereas columns were modeled using 3D framework elements and also triangles. The columns are set perpendicularly to the base and the floors. Both types of meshes show a good accordance of the results. The FE model of the structure is shown in Fig. 3.

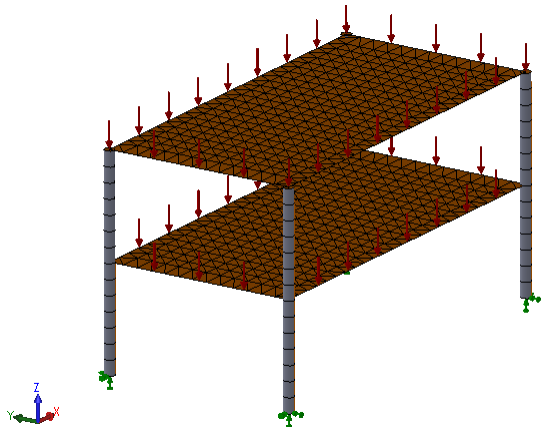

Fig. 3 Finite element model of the structure

Some modeling results and the 5 lowest eigenfrequencies of the flooring structure model without and with defects are presented in Fig. 4, Fig. 5 and Table 1 accordingly.

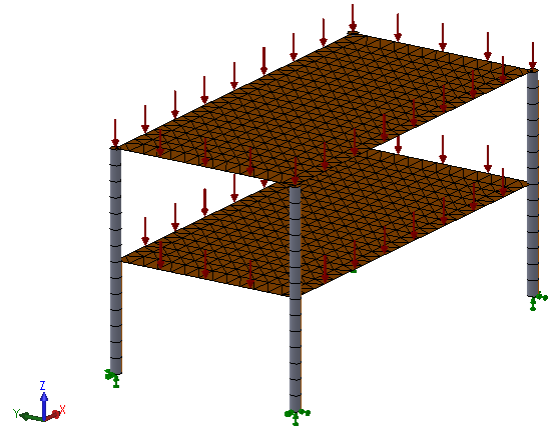

Fig. 4 Deformation of the floor without defect in support

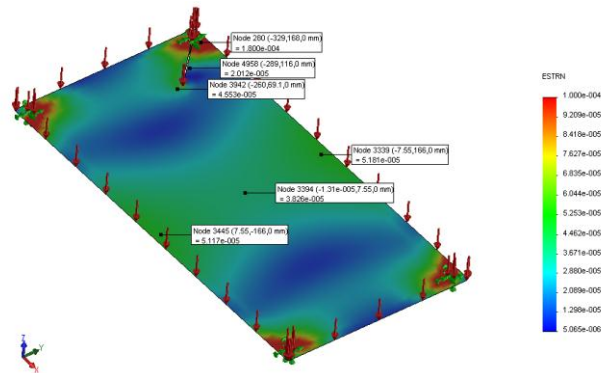

Fig. 5 Deformation of the floor with a single defect in support

Table 1 Natural vibration frequencies of flooring with defects, Hz

Vibration mode	Floor without defects	Floor with single defect	Floor with two defects in two supports	Floor with a defect in the center
1	71.698	71.007	70.125	68.158
2	139.02	136.85	134.54	138.91
3	201.62	200.16	198.15	200.15
4	319.07	315.53	312.32	318.17
5	324.01	322.35	319.49	320.09

4. Mathematical methods

In terms of the mathematical methods, the Fourier transform based approaches are considered as follows.

4.1. Power spectral density

A common approach for extracting the information about the frequency features of a random signal is to transform the signal to the frequency domain by computing the d (DFT). For a block of data of length N samples, the transform at frequency $m\Delta f$ is given by

$$X(m\Delta f) = \sum_{k=0}^{N-1} x(k\Delta t) e^{j\frac{2\pi km}{N}} \tag{1}$$

where Δf is the frequency resolution and Δt is the data-

sampling interval. The auto-power spectral density (APSD) of $x(t)$ is estimated as

$$S_{xx}(f) = \frac{1}{N} |X(m\Delta f)|^2, f = m\Delta f \quad (2)$$

The cross power spectral density (CPSD) between $x(t)$ and $y(t)$ is similarly estimated. The statistical accuracy of the estimate in Eq. (2) increases as the number of data points or the number of blocks of data increases [13-15].

4.2. Short Time Fourier Transform and spectrogram

The Short Time Fourier Transform (STFT) introduced by Gabor 1946 is useful in presenting the time localization of frequency components of signals. The STFT spectrum is obtained by windowing the signal through a fixed dimension window. The signal may be considered approximately stationary in this window. The window dimension fixed both time and frequency resolutions. To define the STFT, let us consider a signal $x(t)$ with an assumption that it is stationary when it is windowed through a fixed dimension window $g(t)$, centered at time location τ . The Fourier transform of the windowed signal yields the STFT [13-17].

$$STFT\{x(t)\} \equiv X(\tau, f) = \int_{-\infty}^{+\infty} x(t)g(t-\tau)e^{-j2\pi ft} dt \quad (3)$$

The equation maps the signal into a two-dimensional function in the time-frequency (t, f) plane. Time-frequency analysis identifies the time at which various signal frequencies are present, usually by calculating a spectrum at regular intervals of time. Examination of the time domain for each of the signals clearly demonstrates their differences and their time varying nature, however the spectral content of these signals remains predominantly concealed.

The analysis depends on the chosen window $g(t)$. Once the window $g(t)$ is chosen, the STFT resolution is fixed over the entire time-frequency plane. In discrete case, it becomes

$$STFT\{x(n)\} \equiv X(m, f) = \sum_{n=-\infty}^{+\infty} x(n)g(n-m)e^{-j\omega n} \quad (4)$$

The magnitude squared of the STFT yields the spectrogram of the function.

$$Spectrogram\{x(t)\} \equiv |X(\tau, f)|^2 \quad (5)$$

5. Data collection system of the building structure

In this experiment, the sampling frequency is 4098 Hz. The analysis of the data from measurement system was performed using the MATLAB. For this purpose, considered measurement and data collection system is shown by Fig. 6.

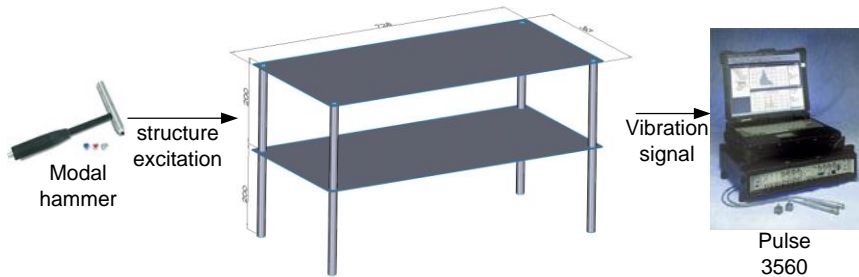

Fig. 6 Data collection system

5.1. Analysis for the building structure data

In order to analyze the dynamics of the building construction layers, the experimental structural system was set-up and excited with modal hammer (Fig. 6). The results were measured using Brüel and Kjear Pulse 3560. Experimental data: acceleration of different points of floor

(Fig. 2) with damage 1, damage 2 and undamaged floor, and velocity is as well. All data is first of all, compared to each other.

In this sense, the time domain variations related to the building structure case are shown by the following figures.

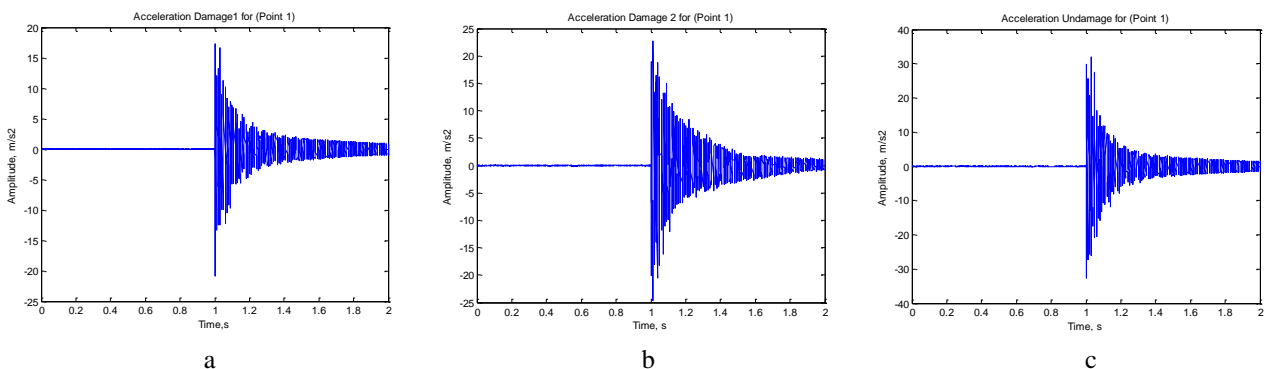

Fig. 7 Acceleration at the point 1 when the measured floor is (a) with defect 1; (b) with defect 2; (c) without defect

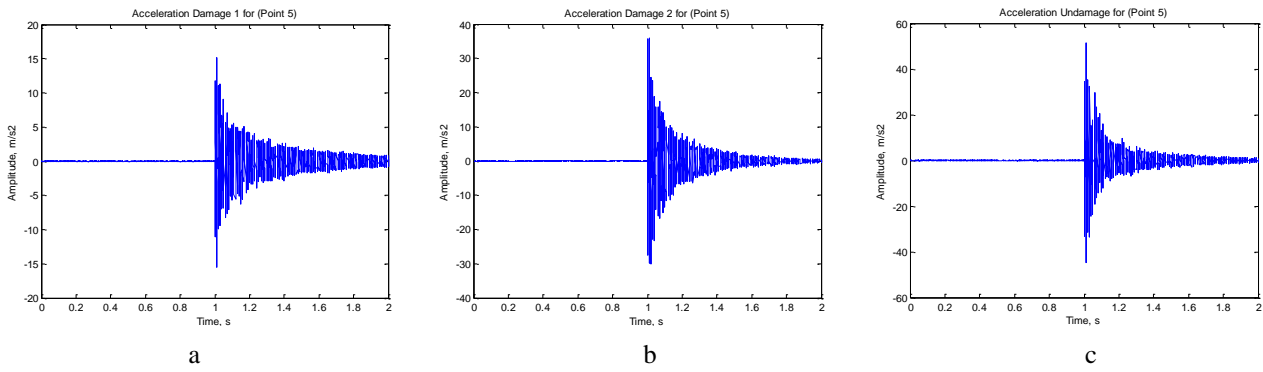

Fig. 8 Compare to Damage and Undamaged Floor Accelerations for Point 5

Fig. 7 and Fig. 8 shows the dynamics of acceleration at point 1 and point 5 respectively after excitation using modal hammer. To distinguish differences in the change of the accelerations are shown on the same figure. Graphics lets examine the similarities.

6. Time-frequency analysis for the building structure data

In the structures deformation, acceleration, velocity and power will be examined as a comparison of results of time frequency analysis.

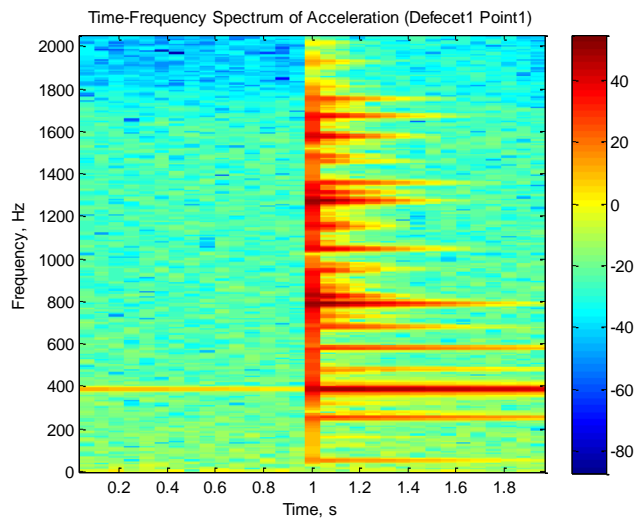

Fig. 9 Time-Frequency spectrum of the point 1 acceleration when the floor has defect 1

Fig. 9 depicts the time-frequency spectrum of the acceleration at point 1, when the floor has defect 1. Here high-amplitude frequencies around 450 Hz are observed. This situation can be considered as the fundamental frequency for this point. Other plots are examined in the different frequency components of each graph are seen to be effective.

Fig. 10 presents the results of the time-frequency analysis of the point 5, the floor is with defect 1.

The high-amplitude frequencies of the parameters at point 5 are more dominant.

Time-frequency analysis of the floor without defect is presented in Fig. 11. Here, there are no frequencies between 400-800 Hz or the amplitudes are low. However, the analysis of defect in the intensive frequency components between 400 Hz and 800 Hz are available.

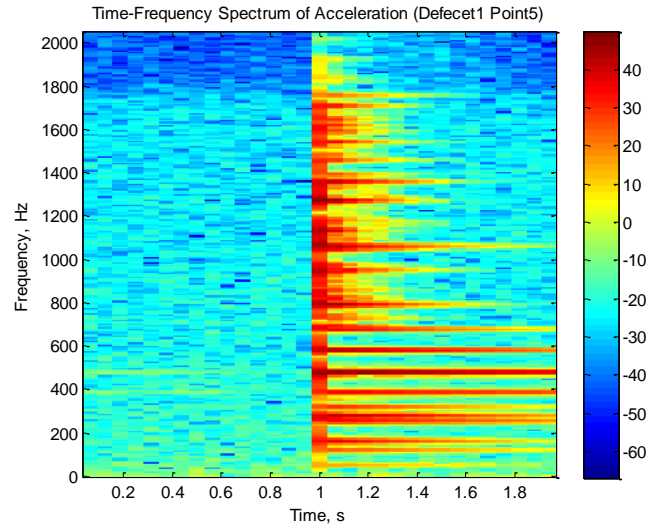

Fig. 10 Time-Frequency spectrum of the point 5 acceleration when the floor has defect 1

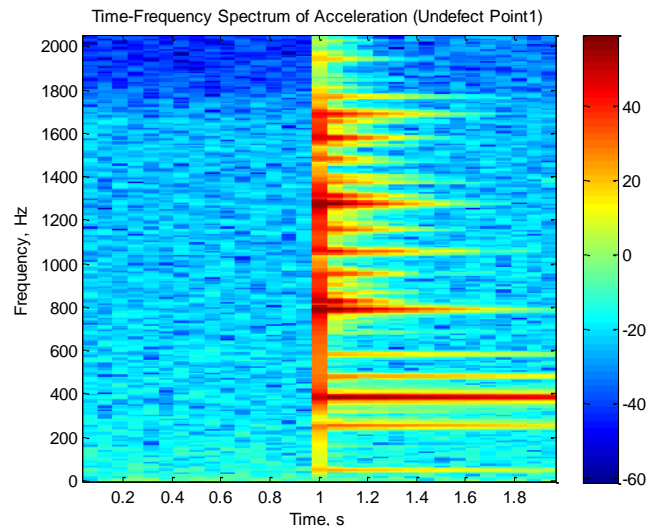

Fig. 11. Time-Frequency spectrum of the point 5 acceleration when the floor is without defect

The results of the analysis of the structures with defect and without defect are compared in Fig. 12 where differences between those areas are shown. In the marked regions, the amplitude of the frequency cannot be read.

PSD analysis is examined in Fig. 13, it shows that here are two harmonic components: the first frequency is 380 Hz, and the second 780 Hz near multiples of the frequency of 380 Hz.

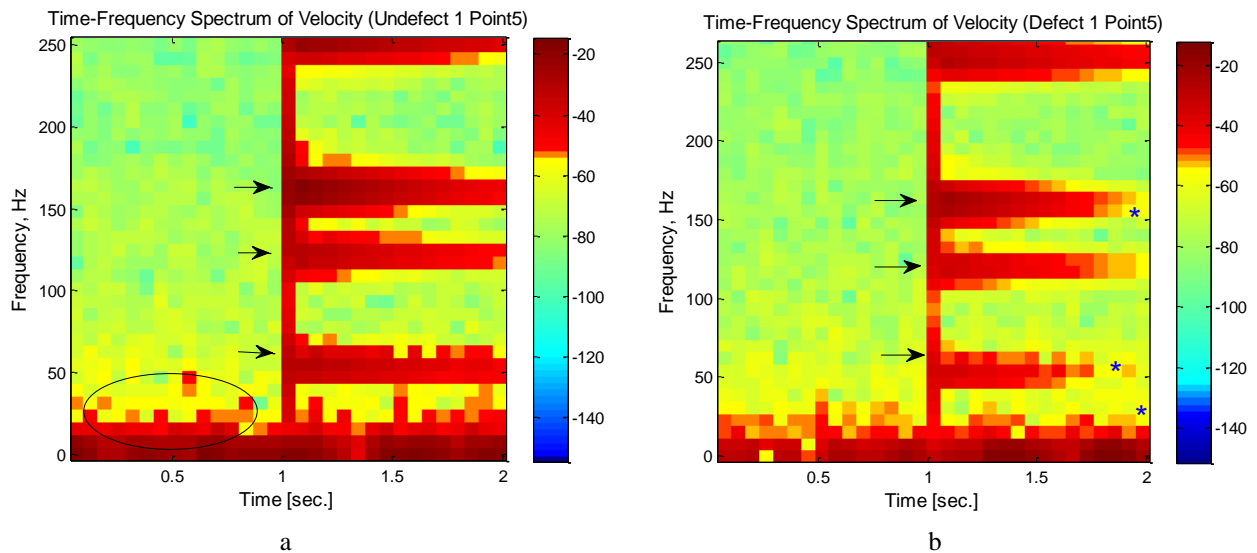

Fig. 12 Comparison of the spectrum of velocities at point 5 on the floor without defect (a) and with defect 1 (b)

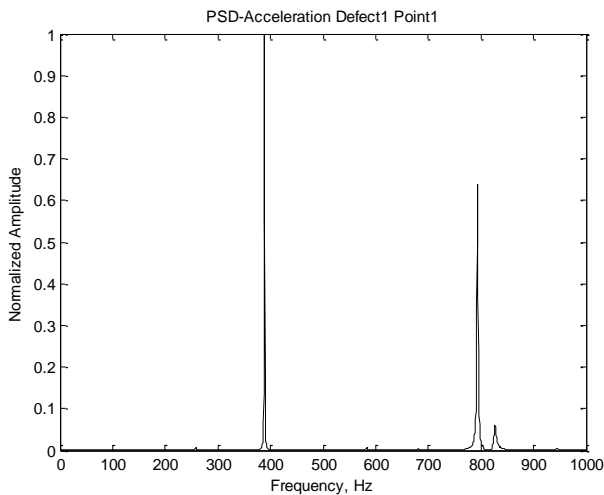

Fig. 13 PSD analysis of Acceleration

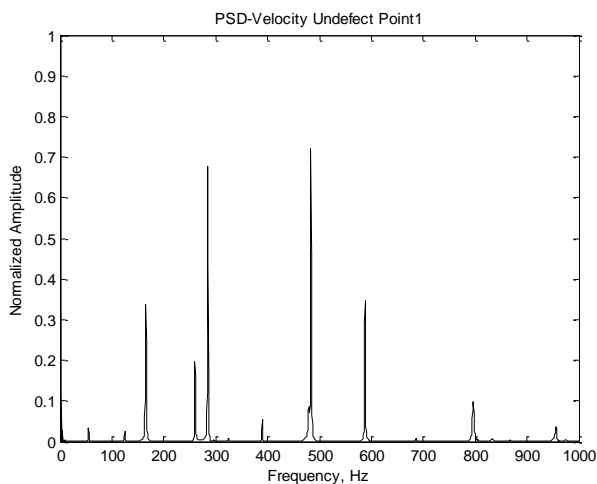

Fig. 14 Power Spectrum density

Comparing the results of dynamical experiment and analysis of floor construction the ratio of experimentally and analytically determined lowest frequency relative difference is not higher than 5%. In particular the experimental results are consistent with the results of FEM analysis.

7. Conclusions

In this study, a new analysis method for the detection of damage to buildings was investigated. The method is applied on real experimental systems. First, on the experimental systems the sensors are placed on the designated spots. These sensors are used to measure the pulse. After excitation the measurements of the velocity, power, and acceleration of the plate were made. Meaningful analysis of the data has been obtained.

In addition, spectral analysis of all data in the study was made. Significant findings include the results of spectral analysis. This method is very useful to diagnosis of the high-frequency regions. The results of the analysis performed with the data obtained from the areas with defect and without it allow making comparison of the results of spectral methods. The analysis of the power spectrum densities was also performed. These results can be achieved important diagnostically features. Figure 14 shows the PSD for the given velocity to be undamaged. Analysis of the PSD analysis of the damaged and undamaged regions contains important findings of the useful for the determination of building's structure state. The findings are evaluated; the results have proved to be consistent and positive for the diagnostics of building's state.

Acknowledgments

The presented work was funded by the grant (No. MIP-71/2010) from the Research Council of Lithuania.

References

1. Volkovas, V.; Petkevicius, K. 2011. Modeling and identification of building's construction defects, Proceedings of the World Congress on Engineering 2011 Vol III, WCE, London, U.K., 3: 2518-2522.
2. Monitoring of buildings and structures, security structures span (available in Russian in <http://www.stroinauka.ru/d26dr7429m0rr6098.html>).
3. Chen, J.S.; Pan, C.; Wu, C.T.; Liu, W.K. 1996. Reproducing Kernel Particle Methods for large defor-

- mation analysis of non-linear structures, *Computer Methods in Applied Mechanics and Engineering* 139(1-4): 195-227.
4. **Petkevicius, K.; Volkovas, V.** 2011. Monitoring and identification of structural damages, *Mechanika* 17(3): 246-250.
<http://dx.doi.org/10.5755/j01.mech.17.3.498>.
 5. **Sanayei, M.; Onipede, O.** 1991. Damage assessment of structures using static test data, *AIAA Journal* 29(7): 1174-1179.
 6. **Banan, M.R.; Banan, M.R.; Hjelmstad, K.D.** 1993. Parameter estimation of structures from static response. I: Computational aspects, *Journal of Structural Engineering* 120(11): 3243-3258.
 7. **Ozen, G.O.; Kim, J.H.** 2007. Direct identification and expansion of damping matrix for experimental analytical hybrid modelling, *Journal of Sound and Vibration* 308: 348-372.
 8. **D'Ambrogio, W.; Fregolent, A.** 2010. The role of interface DoFs in decoupling of substructures based on the dual domain decomposition, *Mechanical Systems and Signal Processing* 24: 2035-2048.
 9. **de Klerk, D.; Rixen, D.J.; Voormeeren, S.N.** 2008. General framework for dynamic substructuring: History, review, and classification of techniques, *AIAA Journal* 46(5): 1169-1181.
 10. **Eun, H.C.; Lee, E.T.; Chung, H.S.** 2004. On the static analysis of constrained structural systems, *Canadian Journal of Civil Engineering* 31: 1119-1122.
 11. **Kudzys, A.; Lukoševičienė, O.** 2009. On the safety prediction of deteriorating structures, *Mechanika* 4(78): 5-11.
 12. **Rainer, J.H.** 1986. Applications of the Fourier Transform to the Processing of Vibration Signals, Noise and Vibration Section Institute for Research in Construction, National Research Council Canada, Ottawa, March 1986.
 13. **Vaseghi, S.V.** 2000. Advanced Signal Processing and Digital Noise Reduction, 326-328.
 14. **Seker, S.** 2000. Determination of air-gap eccentricity in electric motors using coherence analysis, *IEEE Power Engineering Review* 20(7): 48-50.
 15. **Taskin, S.; Seker, S.; Karahan, M.; Akinci, T.C.** 2009. Spectral analysis for current and temperature measurements in power cables, *Electric Power Components and Systems* 37(7): 415-426.
 16. **Akinci, T.C.** 2011. The defect detection in ceramic materials based on time-frequency analysis by using the method of impulse noise, *Archives of Acoustics* 3(6-1): 1-9.
 17. **Akinci, T.Ç.; Ekren, N.** 2011. Detection of the ferroresonance phenomenon for the west anatolian electric power network in Turkey, *Acta Scientiarum Technology* 33(3): 273-279.

V. Volkovas, K. Petkevicius, M. Eidukevičiūtė,
T.C. Akinci

PASTATO KONSTRUKCIJŲ DEFEKTŲ DIAGNOSTIKA NAUDOJANT LAIKO-DAŽNIO ANALIZĘ

R e z i u m ė

Straipsnyje nagrinėjama pastatų perdangų defektų aptikimo ir identifikavimo problema. Siekiant iširti perdangų elgseną esant defektui ir be jo, perdangų defektai buvo modeliuojami naudojant fizikinius bei BE modelius. Buvo atlikta pastato statinio laboratorinio modelio perdangų modalinė analizė ir dažnio – laiko srityje išanalizuoti gauti duomenys. Perdangų dinamikos pokyčių duomenų Furjė analizė ir nustatytos laiko dažnių diagramos, esant įvairiems defektams, parodė, kad ši metodika gali būti naudojama perdangų defektų diagnostikai. Iš gautų duomenų taip pat buvo nustatytas galios spektro tankis, koreliuotas su perdangų būklės pasikeitimu.

V. Volkovas, K. Petkevicius, M. Eidukevičiūtė,
T.C. Akinci

ANALYSIS OF BUILDING'S CONSTRUCTION DEFECTS BY USING TIME-FREQUENCY ANALYSIS

S u m m a r y

The paper analyzes the problem of detection and identification of the defects in the layers of the buildings. In order to analyze the behaviour of the damaged and undamaged layer, the defects in the layers were modelled using physical and Finite Element models. The modal analysis of building's laboratory model prototype layer was performed and the results in the field of time-frequency were analyzed. Fourier analysis of the changes in layer dynamics with various defects showed that the method can be used for layer defect diagnostics. The results also allowed determining power spectral density, which correlates with the changes in layer condition.

Keywords: Short Time Fourier Transformation, fault detection, building's construction.

Received May 20, 2011

Accepted August 21, 2012