

Investigation of the experimental car body in static bending and torsion

V. Dzerkelis*, Z. Bazaras**, J. Sapragonas***, V. Lukoševičius****

*Kaunas University of Technology, Kęstučio 27, 44312 Kaunas, Lithuania, E-mail: vytautas.dzerkelis@ktu.lt

**Kaunas University of Technology, Kęstučio 27, 44312 Kaunas, Lithuania, E-mail: zilvinas.bazaras@ktu.lt

***Kaunas University of Technology, Kęstučio 27, 44312 Kaunas, Lithuania, E-mail: jonas.sapragonas@ktu.lt

****Kaunas University of Technology, Kęstučio 27, 44312 Kaunas, Lithuania, E-mail: vaidas.lukosevicius@ktu.lt

crossref <http://dx.doi.org/10.5755/j01.mech.18.4.2345>

1. Introduction

With more strict requirements for passenger safety, the body function has become more complex - in addition to protection from the elements, it was necessary to reduce noise and vibrations to an acceptable level. The body construction has taken over a part of functions of the frame as a load-body structure, and became more and more rigid to ensure functionality of the car's body structure and the deformation zones [1].

Using modern methods of supporting structural analysis and numerical simulation by finite element method (FEM) allows to develop and optimize the car's body quite easy. However, a detailed analysis of the initial stage of calculation becomes more complicated because most of the necessary information required for an accurate analysis, is determined only in later stages of design [2]. Numerical analysis is complicated by the fact that for initial estimates the structure design has to be simplified making certain assumptions for body structural members, which may affect the final car structure body stiffness and strength of the car structure [3]. Later the results were compared with those obtained during an exterior experiment.

The aim of this paper is to compare the data of the designed experimental vehicle calculated by finite element method with the data of static bending and static torsion obtained experimentally, define an impact of assumptions made during the development of a computational model on the results, evaluate how the computer simulation results obtained differ from the experimentally obtained ones due to the assumptions made. The test results of the vehicle load-body structure would allow to anticipate the likely behavior in certain situations that might arise during the operation.

2. Experimental research

According to procedures and requirements provided in references static torsion and bending tests were performed during the experiment.

The simplified experimental techniques used in this paper are applied to experimental, modified vehicles, therefore the results achieved during the experiment may be used for analysis only as providing a potential behavior of the body structure of a modified car in certain situations that might arise during the operation.

During the experimental testing according to the procedures and requirements determined in references measuring equipment has been used:

- Displacement sensors ICh 10:

- measurement range, mm: 0 – 10;
- graduation interval, mm: 0.01;
- 0.1 mm error using 6 mm measurement scale;
- 1 mm error using 10 mm measurement scale.
 - Laser spirit levels GWP - LS6:
- wave length: 650 nm;
- tolerance: ± 1 mm/m.
 - Scales Computerscales® AccuSet™ 1.0.0:
- number of measurement points: 4;
- sensors: tenzo;
- range of operational temperatures: -30°C - $+60^{\circ}\text{C}$;
- maximum permitted load on one platform: 11 kN.

The scales before each experiment were calibrated with the 10 kg mass standard included. The load is changed using the equivalent mass at the unit installation place. For the test 8 standard packages of 250 N each were prepared, in addition to them, for simulating batteries and a fuel tank three standards of 500 N were prepared. Since the sand packages were used to imitate weight, their weight before each experiment was checked by scales. In order to assess redistribution of reaction of car supports, the latter shall be weighed before the tests.

After stiffness tests of the body structure of the experimental car in static bending and static torsion the obtained results were analyzed by comparing them with the established stiffness norms of the body structures [2].

2.1. Static bending test

During the experiment, all car body parts tightened by screws were removed, instead of the fuel tank and batteries in certain locations equivalent weights of the units were applied (Fig. 1, points B₁-B₅). With respect to the regulated standards of operating conditions the equivalent weights are placed on each car seat to simulate passengers.

The vehicle is equipped with displacement sensors on both sides. The sensors are placed on the car sill as close as possible to the vehicle axles and the middle base of the car.

Strengthening conditions of three-dimensional frame used during the analysis for the case of static bending are shown in Fig. 1.

Displacement of the three-dimensional frame in case of static bending in the vertical direction is restricted in four-point suspension mounting (Fig. 1, points A₁-A₄), leaving a possibility to the car body typical points to move only along the symmetry axis of the vehicle.

Only one degree of freedom is left to support points of rear suspension axle (Fig. 1, points A₁, A₂), longitudinal displacement of the body points is supposed al-

lowing moving the front car axle.

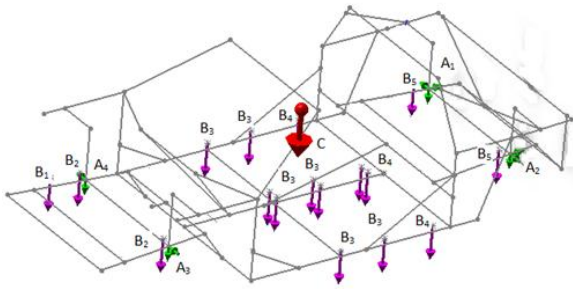

Fig. 1 Conditions of body fixation and loading conditions for static bending test (C – the force of gravity)

Measurements were carried out by changing a car load of 250 N symmetrically on each seat.

After bending testing deflections of specific points of body structure sill on the car base were determined.

The experiment showed that from the very beginning deflection of the left side of the car was 7% higher than of the right.

Body in mind the fact that the sides of car load-body structure are identical this might have been caused by the fuel tank of 25 kg moved to the left side of the car.

This proves that the assumptions about symmetrical load are not exact.

After reloading the car the body structure returns to its original position without any permanent deformation because during the tests tensile stresses acting on the structure did not exceed the elasticity limit.

Analysis of tests results demonstrated that at maximum possible car load of 1962 N the largest deflection on the base was 1.58 mm. Analysis of car body testing regulations [2] revealed that for series car production, deflection of the car structure in base could not be greater than 1 mm, but provides the clause that operation of an experimental or professionally modified car is possible, although they do not meet the stiffness requirements to vehicles of series production.

2.2. Static torsion testing

During diagonal torsion test a vehicle is prepared by simulating the fuel tank and electric batteries.

The rear car axle, like during the bending test, is rigidly fixed (Fig. 2, points A-B). One end of the under-frame of the front suspension also is fixed rigidly, leaving a possibility to the body structure during testing to rotate about an axis of point fixed (Fig. 2, point C). In order to evaluate just stiffness of the body structure for torsion, excluding the contribution of the suspension elements to the final results, supports are fixed to suspension under-frame in places of its attachment to the frame. The experiment was carried out with an empty and with the loaded car.

Applied torque is set in the under-frame right side of the front supporting the suspension attachment point (Fig. 2, point D) by a lifting device, placing the latter on the scales. During the test with the help of the lifting device front right side of the car is gradually lowered. While monitoring readings weight per point is compensated by

the increment of 50 kg, with recalculating the support respond to the acting moment. The testing is continued until the scales are fully unloaded.

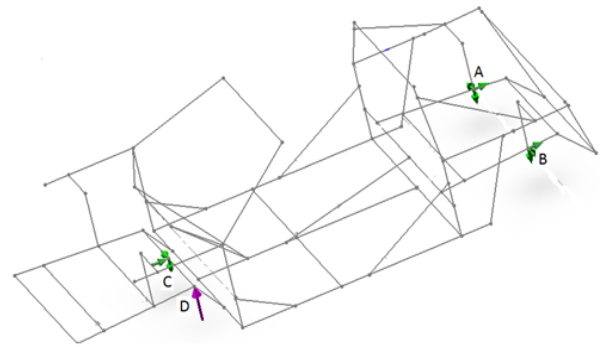

Fig. 2 Conditions of body fixation and loading conditions for static torsion test

To define torsion angle of the body structure laser spirit levels were used. They were mounted in top point of the mounting of suspension shock absorbers.

The reference scale was installed in the laboratory in front of the laser equipment. The distance between the opposing axle stands was measured. During the testing, with gradual changing of the moment, a laser beam displacement was marked on the reference scales.

During the static torsion experiment a torque was determined by the equality

$$M = (m_0 - m_i) 9.81 l \quad (1)$$

where m_0 is an initial weight for a point, kg; m_i is compensated weight left in the i -th test, kg; l is the distance between reference equipment and support points, m.

The static torsion testing demonstrated that at the torque of 3789 Nm the body structure twists till 0.93 degree (Fig. 10). From the given dependence it is clear that the car body during the experiment has been unloaded without any residual deformations. Torsion angle of the body structure is linearly dependent on the applied torque.

3. Methodology for the frame calculating by finite element method

After analysis of simulation methods of body structures described in references, the real body design for calculations carried out is simplified. According to recommendations the spars of the experimental car studied and other similar body elements are replaced by the bars of the standard profiles (Fig. 3) [2-5]. Mechanical properties of steel are presented in Table 1.

Table 1

Mechanical properties of steel AISI 304 [6]

Property	Value	Unit of measure
Modulus of elasticity	1.9×10^5	MPa
Poisson's ratio	0.29	
Shear modulus	7.5×10^4	MPa
Density	7900	kg/m ³
Tensile strength limit	586	MPa
Yield strength	241	MPa

Stiffness of the car body panels (the front interior wall, floor boards and inner wing panels) and the influence of front and rear glass, engine and boot covers on the overall stiffness of the car body are not considered in the calculations.

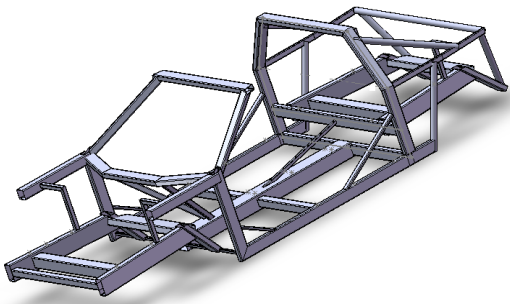

Fig. 3 Structure of car's simplified body 3D frame

During the numerical model analysis the structure is loaded with static loads without evaluating dynamic coefficient. The structure has been analyzed using SolidWorks Simulation package.

3.1. Analysis of 3D-model static bending

For FEM analysis the same fixation and loading conditions of the three-dimensional frame for the static bending experiment (Fig. 1) were used. The obtained results at bending testing scheme are presented in Figs. 4 and 5. Stress distribution in the structure in case of static bending is given in Fig. 4.

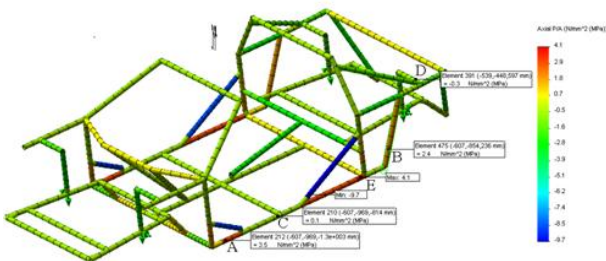

Fig. 4 Stress acting in the body structure in the case of static bending

Analysis showed that maximum stress in the loaded structure was equal to 4.1 MPa (bars of structure are made from steel with yield strength 206.8 MPa). By gradually loading the body structure vertical displacements of typical sill points have been obtained.

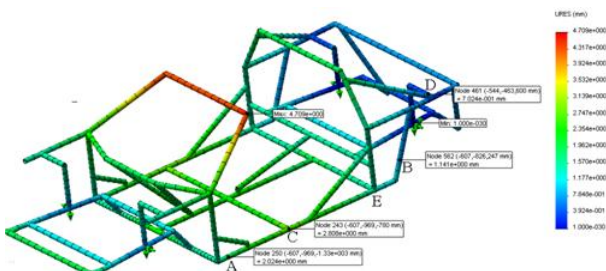

Fig. 5 Displacements of the body structure points for the case of static bending

It was found that the biggest displacement of the point in the front window on the upper transverse of three-

dimensional load-body structure loaded with 1962 N is 4,7 mm. Evaluation of the obtained results demonstrated that the vertical displacement of the middle point of the car sill at maximum designed loading of 1962 N, is equal to 2,93 mm.

Dependence of displacement of the middle sill point on the car is presented in Fig. 9.

From the diagram we can see that theoretically displacement of the car load-body structure is linearly dependent on a body load. Since yield strength of the material is not exceeded, with lowering loading the structure returns back into its initial position.

3.2. Analysis of 3D-model static torsion

An absolute stiffness to torsion of load-body structure of the car studied is defined by the maximum operational torque which with regard to support responds acting on suspension support points is calculated according to the scheme presented in Fig. 6, a. According to Fig. 6, b scheme maximum torque acting on the car load-body structure - M_{sb} :

$$\text{If } R_f > R_r, \text{ then } M_{sb} = R_r \frac{b_f}{2} \quad (2)$$

In case of diagonal torsion vertical reactions of wheels of more loaded car axle - R_{fTL}, R_{fTR} (Fig. 4)

$$\left. \begin{aligned} R_{fTL} &= \frac{R_f}{2} + R_f' = \frac{R_f}{2} + \frac{M_{sb}}{b_f} \\ R_{fTR} &= \frac{R_f}{2} - R_f' = \frac{R_f}{2} - \frac{M_{sb}}{b_f} \end{aligned} \right\} \quad (3)$$

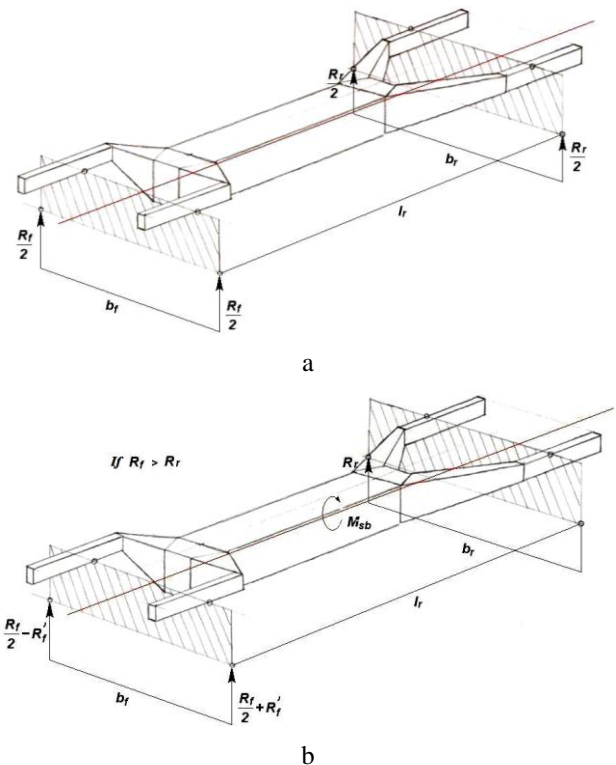

Fig. 6 Loading of the body structure in the diagonal torsion case: a – scheme of defining of support responds, b – diagonal torsion scheme

During the study carried out the biggest possible applied support respond acting during operation is equal to 4621 N.

Torque is determined from the equation

$$T = F l \tag{4}$$

here T is torque, Nm; F is support respond, N; l is the distance from force application point to center line of the car, m.

In the car body testing regulations [2] there is the requirement that at the torque of 4000 Nm the load-body structure in the car base could not twist more than one degree. In case of static torsion the displacement of body three-dimensional frame is restricted while the rear suspension mounting points restrict all six degrees of freedom.

The point in the middle of the front axle of the car is fixed by restricting displacements of the point along the x, y, z axes.

The structure has the only possibility to turn about this point left. The reaction is applied in one of rear points of the axle of suspension.

The obtained results in case of static torsion test scheme are shown in Figs. 7 and 8. At static torsion stress distribution in the structure is presented in Fig. 7.

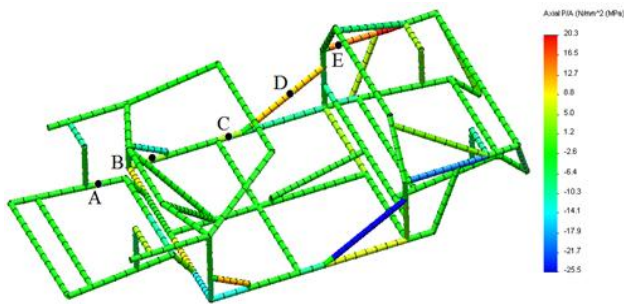

Fig. 7 Stresses acting in the load-body structure during static torsion

The static torsion analysis revealed that during the study to twist the structure using the torque of 4000 Nm maximum stress has been 20.3 MPa, the obtained stress did not exceed yield strength. Maximum stress, during study using the torque of 4000 Nm, was 20.3 MPa.

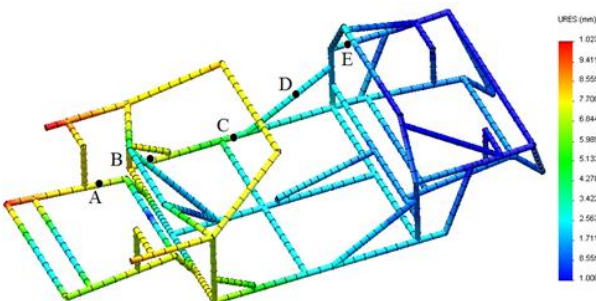

Fig. 8 Displacements of the points of the body structure during static torsion

During static torsion testing dangerous points of the structure were detected (Table 2). The largest dis-

placement of the point of the body structure was 10.2 mm.

The testing demonstrated that used torque and torsion angle of the front axle (Fig. 10) are linearly dependent. At the beginning and end of dependence the observed fracture is caused by non-compliance of the different first load value with further load gradation.

It appears that at the application of the torque of 3789 Nm torsion angle is equal to 1.16 degree.

Table 2 Dangerous points of the structure, their displacements and acting stresses detected during torsion testing

Dangerous point of load-body structure	The stresses acting in the point, MPa	Point displacement, mm
A	-0.3	6.9
B	5.8	8.06
C	2.7	5.63
D	12.1	3.43
E	9.4	2.47

Since during analysis the model in rear axle was fixed absolutely rigidly, we can conclude that torsion angles of the load-body structure and the front axle are equal.

In view of the requirements to car body structures which recommend torsion of the body structure in the car base to be no more than one degree with the applied torque of 4000 Nm and the results obtained during the analysis we can say that the car simplified body structure does not meet the stiffness requirements to torsion applicable to vehicles in series production.

In view of the fact that the results obtained are close to the values specified in the regulations, and the studied vehicle is experimental, in accordance with the recommendations of SAE the car could be operated.

4. Comparison of experimental and theoretical results

While doing numerical and exterior experimental testing, during static bending analysis it was found that the results obtained by FEM model and experimental ones differ about twice (Fig. 9). Both the data obtained by FEM model and experimental data have the linearity and yield strength of the structural material is not exceeded.

Diagrams of dependencies of testing carried out have the same trend in change.

The resulting difference between the results of separate studies indicates how during the numerical experiment, using the FEM, the assumptions made, (such as the real car panels with stiffness edges rejected) affect the final parameters of strength and stiffness of car body structure.

During the analysis of static torsion results (Fig. 10) it was noticed that the dependencies given in the diagram are of the same trend, but between different models the results differ about 1.27 times. As in the case of bending, we can say that this difference is caused by assumptions made during the simplifying of load-body structure, ignoring stiffness of the car body panels and greater stiffness of the joints.

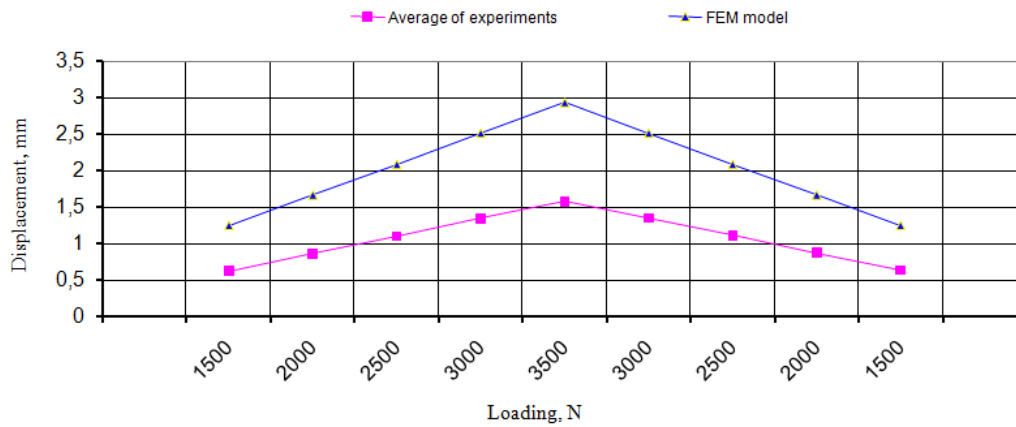

Fig. 9 Results obtained during the numerical simulation and experiment in the case of static bending

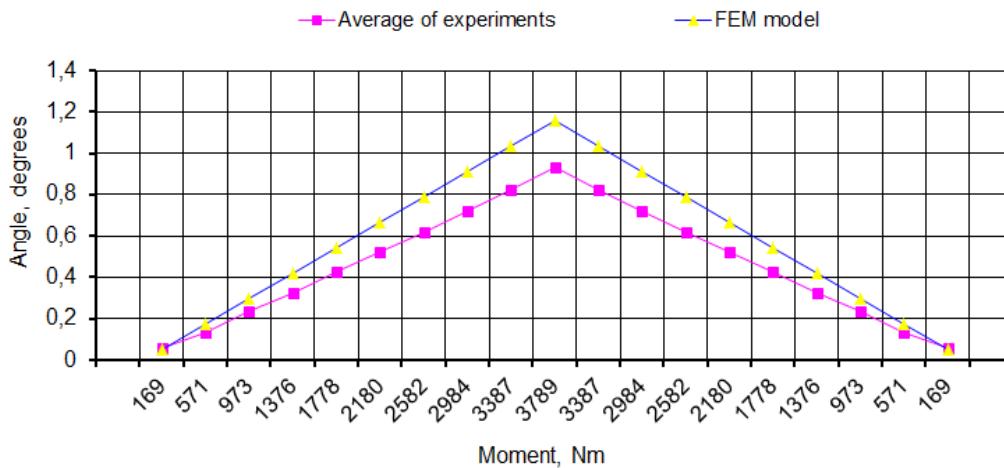

Fig. 10 Results obtained during the numerical simulation and experiment in the case of static torsion

5. Conclusions

1. The simplified numerical model of the load-body structure of an experimental car has been developed, and dangerous points of the load-body construction have been detected.

2. After the experimental static bending and static torsion testing of the car body it was found that deflection of the body structure in the car base is equal to 1.58 mm. Regulations state that deflection of the load-body structure in base of the cars in serial production can not be greater than 1 mm.

3. During diagonal torsion testing of the load-body structure at the torque of 3789 Nm the load-body structure twists up to 0.93 degree. Regulations prescribe that torsion in the base of the load-body structure can not be greater than 1 degree at the bending moment of 4000 Nm. The analysis of the dependencies obtained allows the conclusion that the results are close to the requirements applicable to unit and serial production of cars.

4. While calculating static bending, the difference between the results presented by different models is about 2 times. Gradually loading the load-body structure the difference of equivalent stress and displacement between the results of the models examined stabilizes. The assessment of deflections in dangerous points indicates that the models considered basically do not differ in the results.

5. In the case of static torsion difference between the results provided by different models is about 1.27

times. Gradually increasing the torque, the difference of equivalent stress and load-body structure torsion angles between the results of the models studied stabilizes. Assessing the dependencies obtained, we can conclude that the models considered provide the essentially not differing results.

References

1. **Juodvalkis, D.; Sapragonas, J.; Griškevičius, P.** 2009. Effects of spot welding on the functionality of thin-wall elements of car's deformation zone, *Mechanika* 3(77): 34-39.
2. **Genta, G.; Morello, L.** 2009. *The Automotive Chassis Vol.1: Components Design*. Torino: Springer. 627p.
3. **Zielinski A.** 2003. *Konstrukcja nadwozi samochodow osobowych i pochodnych*. Warszawa: Wydawnictwa Komunikacji i Łączności. 440p.
4. **William, H.** 1995. Aluminum automotive space frames, *Automotive Engineering* 8(103): 81-85.
5. **Holt, D.** 1995. Steel launches offensive, *Automotive Engineering* 11(103): 20-21.
6. Alloys of steel review (preview: 2012.05.10). http://www.substech.com/dokuwiki/doku.php?id=stainless_steel_aisi_304.

V. Dzerkelis, Z. Bazaras, J. Sapragnas, V. Lukoševičius

STATIŠKAI LENKIAMO IR SUKAMO
EKSPERIMENTINIO AUTOMOBILIO KĖBULO
TYRIMAS

Re z i u m ė

Atlikto tyrimo metu sudarytas supaprastintas eksperimentinio automobilio laikančiosios konstrukcijos skaitinis modelis, nustatyti pavojingi laikančiosios konstrukcijos taškai. Darbe aptarta skaitinio modelio sudarymo formalizavimo eiga, palyginami skaitiniu ir eksperimentiniu būdu gauti rėmo standumo ir charakteringų taškų poslinkių duomenys. Atlikus eksperimentinius statinio lenkimo bei statinio sukimo automobilio kėbulo bandymus nustatyta, kad laikančiosios konstrukcijos įlinkis automobilio bazėje lygus 1,58 mm. Laikančiosios konstrukcijos įstrižo sukimo bandymo metu, esant 3789 Nm sukimo momentui laikančioji konstrukcija susisuka iki 0,93 laipsnio. Skaičiuojant statiniam lenkimui, skirtumas tarp skirtingų modelių pateikiamų rezultatų yra apie 2 kartus. Statinio sukimo atveju skirtumas tarp skirtingų modelių pateikiamų rezultatų yra apie 1,27 karto.

V. Dzerkelis, Z. Bazaras, J. Sapragnas, V. Lukoševičius

INVESTIGATION OF THE EXPERIMENTAL CAR
BODY IN STATIC BENDING AND TORSION

S u m m a r y

During the study conducted a simplified numerical model of the body structure of an experimental car has been developed, dangerous points of the load-body structure have been determined. The formalizing process of the numerical model was discussed in the paper, data of frame stiffness and data of displacement of typical points obtained by numerical and experimental methods have been compared. After a car body experimental static bending and static torsion testing it was defined that deflection of load-body structure in car base is equal to 1.58 mm. During diagonal torsion testing of load-body structure at the torque of 3789 Nm the load-body structure twists till 0.93 degree. When calculating for static bending, difference between the results provided by different models is about 2 times. In case of static torsion difference between the results obtained with different models is about 1.27 times.

Keywords: static bending, static torsion, car body.

Received June 17, 2011

Accepted August 21, 2012