

Controllable Hydraulic Loading Unit for Rowing Simulator

G. Dervinis, K. Sarkauskas

*Department of Electrical Engineering, Kaunas University of Technology,
Studentų 48-320, LT-51367 Kaunas, Lithuania, phone +370 37 300253, e-mails: gintaras.dervinis@ktu.lt, kastytis.sarkauskas@ktu.lt*

V. Grigas, R. T. Tolocka

*Department of Engineering Mechanics, Kaunas University of Technology,
A. Mickevičiaus 37, LT-44244 Kaunas, Lithuania, phone +370 323199, e-mails: vytautas.grigas@ktu.lt, tadas.tolocka@ktu.lt*

crossref <http://dx.doi.org/10.5755/j01.eee.116.10.881>

Introduction

The controllable hydraulic loading unit for academic rowing simulator has been proposed by authors which is able to generate the chosen (programmed) pattern of the rowing force, dependent on various parameters, including rower strength, intensity of rowing, velocity of the boat etc. [1–3]. Basing on the prototype exploited in Kaunas Academy of Physical Education, the authors are working on the rowing machine, which is able to simulate the loading on the oar quite adequate to the on-water rowing by introducing the proposed loading unit to it [4–6].

The rotational hydraulic loading unit (Fig. 1) consists of two chambers, divided by two plates: immobile and movable, the latter connected to the oar. The moving plate (diaphragm) is equipped with the channel(s) of changeable cross-section area for working liquid access from one chamber into another.

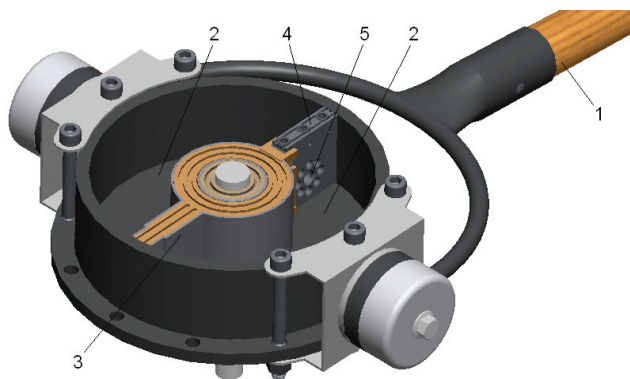

Fig. 1. Loading unit of the rowing machine: 1 – oar handle; 2 – chambers; 3 – immobile plate; 4 – moving plate (diaphragm); 5 – channels

The oar loading is received due to the working liquid pressure on the moving diaphragm, arising when it moves together with the oar during exercising. Its control is realized by changing cross-section area of the channel in the diaphragm of hydraulic cylinder. Development of such rowing machine requires to define the law of change of the mentioned parameter, based on the known law of oar loading during the rowing. The control of the force on the oar handle is ensured by the computerized system equipped with the oar position and velocity sensors and proportional flow control valve *FCV*, regulating the cross-section area of the channel in diaphragm depending on the position and the velocity of the oar [4, 6].

The primary problem of the ongoing development of the rowing machine loading unit was to establish geometric parameters of the unit allowing to achieve the required values of loading on the oar at different intensity of rowing. The experimental and computer aided analysis was aimed to confirm the possibilities to put the chosen method of loading into practice, and to develop the loading unit.

The rowing force and parameters of real academic rowing cycle have been measured experimentally [4]. It was defined that the rowing cycle lasts 1–1.5 s, the oar handle linear velocity is 0.5–2 m/s and the sportsman is able to develop the rowing force up to 2000 N. It allowed us to calculate the maximum values of the necessary velocity of the moving diaphragm and the force on it as 0.2 m/s and 2000 N, respectively.

The hydrodynamic analysis of the loading unit was carried out in order to define the cross-section area of the channel in the diaphragm of the loading unit to achieve the determined load and to vary it in the necessary range. In order to determine the influence of the working liquid viscosity on the loading, computations were carried out with

water and industrial oil I-40A as a working liquid (finite element method was used). The main parameters of the work liquids are given in Table 1.

Table 1. Working fluid parameters

Parameter	Water	Oil I - 40A
Kinematical viscosity, mm ² /s	1.79	35 ... 45
Dynamic viscosity, Pa·s	1.79·10 ⁻³	(51...75)·10 ⁻³
Density, kg/m ³	1000	900

To develop the hydraulic loading unit, able to ensure loading on the oar during the rowing stroke most adequate to the one acting as on-water rowing, some preparatory activities have been carried out based on the information collected during experimental measurements of rowing force and kinematics [4, 5] and computational hydrodynamic analysis of a hydraulic loading unit [5, 6].

For the beginning, the spatial trajectories of the oar handle movement were derived basing on 2D Motion Capture data – the handle end point trajectory (Fig. 2).

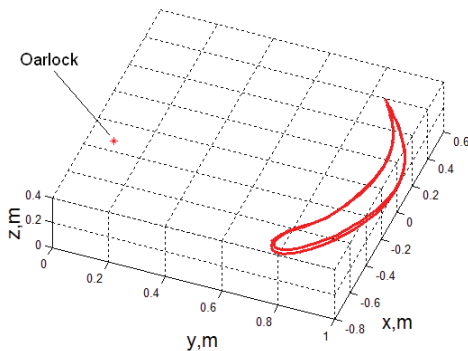

Fig. 2. Oar handle end point trajectory when rowing in the pool

Further, the oar angular velocity (when rotating about oarlock vertical axis) when rowing in the pool was derived (Fig. 3), and finally – the dependence of the force on the hydraulic loading unit diaphragm linear velocity upon time was calculated, taking into account the geometrical parameters of the academical rowing simulator (the length of the oar handle, ~ 1.0 m, and the arm of the hydraulic loading unit diaphragm – 0.1 m). Thereto, typical analytical trigonometric functions and physical equations have been used.

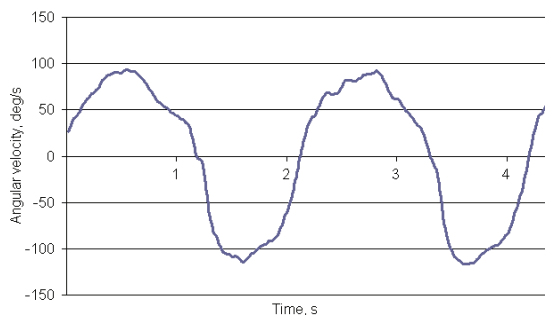

Fig. 3. Dependence of oar handle angular velocity on time when rowing in pool

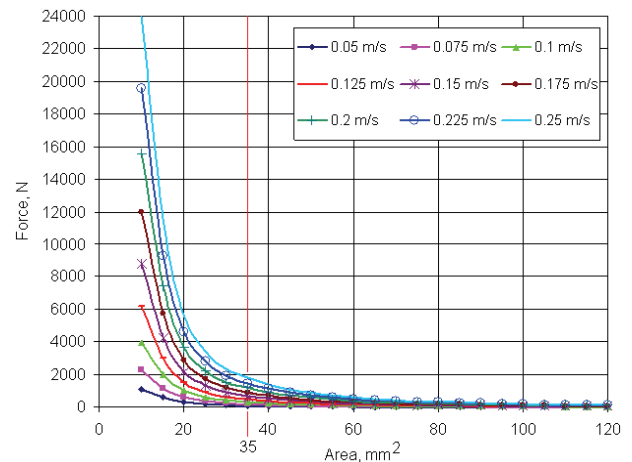

Fig. 4. Dependence of hydrodynamic force generated by hydraulic loading unit on diaphragm channel cross-section area at constant flow velocity

The dependencies of hydrodynamic force from the channel cross-section area at constant velocity were computed also at larger number of velocities of the flow in the hydraulic loading unit, thus collecting the more detailed information about the hydrodynamic resisting force generated by the unit when the oar moves with a different constant velocity (Fig. 4). The computational fluid dynamic analysis by means of corresponding software (Cosmos Floworks) was employed for this purpose.

Loading control by computerized hydraulic system

Control of oar load during the rowing cycle is complicated enough – it is necessary to simulate the real law of its change and synchronize the load on both oars. The computerized hydraulic system is proposed for it, the scheme of which is given in Fig. 5.

The control system performs two different functions: ensures the load depending on position of the oar and helps to improve rowing technique.

The channel diameter control may be performed by using a proportional flow valve. The main factors for its selection are the flow yield and fast enough response. In accordance with this, it was defined that Rexroth Bosch Group valve FRE 6 B -2X/25QK4RV with maximum flow rate 25 L/min is suitable in this case.

The system is measuring angular positions of the oar and controlling channel diameter of loading unit corresponding to it. It can be easily expanded to accumulate and store the information on the parameters of exercising. The ongoing investigation is foreseen to define the law of flow channel diameter control to make the rower loading as close as possible to natural and to carry out experimental investigation of the training facility equipped with the controlled loading unit.

Encoder measuring angle φ (Fig. 5.) defines following parameters of loading device:

1. Depending on the value of the angle forms load to oar;
2. Depending on the changing rate of the angle changes value of formed load;

- Depending on the direction of the changing angle controls load: full or load equal to carry-back of oar load;
- Used for formation of rowing technique without load (for novice-rowers).

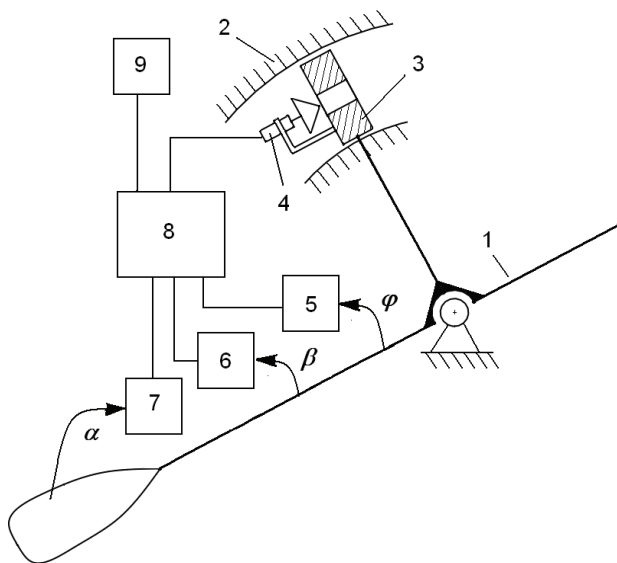

Fig. 5. Computerized system of loading unit control: 1 – oar; 2 – hydraulic loading unit; 3 – moving plate; 4 – proportional flow control valve; 5 – oar angular position sensors; 6 – oar submergence sensor; 7 – oar blade rotation angle sensor; 8 – controller; 9 – control and indication panel

Encoder measuring angle β (Fig. 5.) defines following parameters of loading device:

- Observes changes of angle according reference vertical oar position, which depends on angle φ , and diagram of oar position (Fig. 1.);
- Warns about deviation from reference diagram;
- Forms suppressive forces, when differences from reference diagram are too high, for technique development goals.

Encoder measuring angle α (Fig. 5.) defines following parameters of loading device:

- Observes rotating angle of oar blade depending on movement diagram of blade position;
- Warns about deviation from reference diagram;
- Forms suppressive forces, when difference between angle of blade turns and reference diagram is too high, for technique development goals.

Rowing visualization system (based on industrial SCADA system) performs data entry and information presentation for coach and self-rower in different forms: training mode or real-time mode. Visualization system performs following functions:

- Indicates rowing parameters;
- Warns and indicates the deviations from the ideal rowing technique;
- Allow to change the rowing trajectory and other parameters of the simulator.

Benefits of such simulator will highlight only on the first use it for training purposes. Main features enabling its efficient use consist of two main components.

A first, technical possibility of hardware, real-time responds to the desired control parameters. Encoders (Autonics E40S series - resolution 1000 pulses per rotation) for measurement of angle fully ensures desired operational rate, and at the same time, the oar position encoder for horizontal direction executes speed measurement functions, adjusting load force for simulator.

Second, hardware allows more effective use of training methods and the same athlete improve their technique and compare it with the reference or sample characteristics of the best results the of the athletes reached in the rowing.

We will discuss what new rowing technique possibilities arise from use of this simulator.

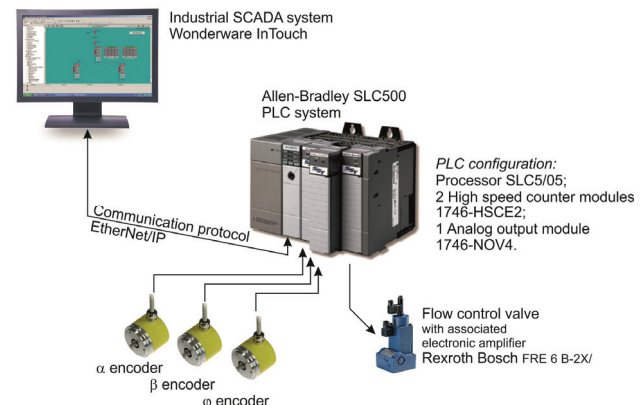

Fig. 6. Supervisory control and data acquisition system for rowing simulator

The suggested control system of rowing simulator (Fig. 6.) is based on the industrial hardware and software. Control system consists of AllenBradley SLC family programmable logic controller (PLC) with SLC5/05 processor, two high-speed counter modules for data acquisition from encoders, analog output module for valve control. SLC5/05 PLC has very fast program execution time, built-in Ethernet communications with EtherNet/IP protocol. High-speed counter modules can operate with discrete signals with input rate up to 1MHz and accuracy $\pm 0.005\%$. For setting of operating modes and data acquisition is used PC, which is connected with PLC through Ethernet (EtherNet/IP protocol), with industrial supervisory control and data acquisition (SCADA) system Wonderware InTouch 9.5 and I/O server. For measurement of oar position are used three encoders.

Training of rowing technique can begin with a simulator in case of minimum load force when improving rowing technique in different phases: lift of oar, blade rotation, the reverse formation, rotating oar, dipping of blade, grasp formation, etc. for formation of following trajectory in all range with own parameters and desired accuracy. This would be especially effective for novice athletes.

Depending on the athlete's height can change the phase size of grasp by setting and changing oar movement trajectory.

Deviations from the ideal trajectory and position of oar have multiple indications:

- Permissible percentage of deviations variation are set for each encoder signal separately or together;

2. Can be illuminant and audible alarm system operating within the range of given tolerance by variations in the light signal and / or strength of the sound;
3. Possible indication of the total information on the screen, and a comparison with the reference;
4. Can be set mode of temporal load, simulating rowing of a specific distance, determining the start, mid-distance and finishing data's for developing rowers rowing tactics and distribution of force in the track;
5. Possible any kind of rowing mode setting: a smooth, accelerating, decelerating, pulsating, etc.

All this possibilities are defined in SCADA system by setting desired operation mode of PLC.

All information is stored in database for later analysis, recount of additional parameters of training.

Summarizing mentioned possibilities of simulator can be determined a lot of parameters, that are not possible to define during real-time rowing.

Conclusions

The oar loading simulating the natural one may be achieved by a hydraulic unit of rowing training facility. The loading unit has been proposed, in which force value during the rowing stroke is regulated by the control of the working liquid flow channel diameter by using a comput-

erized system equipped with the oar angular position and velocity sensors and proportional flow valve.

Control system will allow more effective to use the simulator and even improve training of athlete methodic and is expected to achieve better results in sports.

References

1. **Baudouin A. and Hawkins D.** A biomechanical review of factors affecting rowing performance // *Br. J. Sport Med.*, 2002. – No. 36(6). – P. 396–402.
2. **Kleshnev V.** Boat acceleration, temporal structure of the stroke cycle, and effectiveness in rowing // *Journal of Sports Engineering and Technology*, 2010. – Vol. 224, – No. 1. – P. 63–74.
3. **Bartlett R.** *Sport biomechanics: preventing injury and improving performance.* – Routledge, New York, 1999, – 276 p. <http://dx.doi.org/10.4324/9780203474563>
4. **Grigas V., Domeika A., Legha A., Satkunskiene D., Toločka R. T.** Rowing force and its simulation on training facility // *4th International Conference Mechatronic Systems and Materials*, 2008. – P. 228–229.
5. **Grigas V., Legha A., Šulginas A., Toločka R. T.** Rowing force simulation and control system // *Solid State Phenomena.* – Uetikon–Zuerich: Trans Tech Publications Ltd., 2010. – Vol. 164. – P. 161–164.
6. **Grigas V., Legha A., Toločka R. T.** Simulation possibilities of controlled rowing force generated by hydraulic loading unit of training facility // *Mechanika.* – Kaunas: Technologija, 2009. – No. 2(76). – P. 65–68.

Received 2011 05 24

Accepted after revision 2011 09 13

G. Dervinis, K. Sarkauskas, V. Grigas, R. T. Toločka. Controllable Hydraulic Loading Unit for Rowing Simulator // *Electronics and Electrical Engineering.* – Kaunas: Technologija, 2011. – No. 10(116). – P. 59–62.

The hydraulic oar load unit for rowing simulator has been designed that simulates oar. The device is developed on the base of experimental investigations and computer modeling and ensures the load on the oar similar to the acting during on-water rowing. The load control is organized by the control system consisting of proportional flow control valve and programmable logic controller, changing the working liquid flow through the valve. Three encoders, supported by controller with PC-based supervisory control and data acquisition system are used for positioning of the oar. Suggested system allows significantly expand simulator using possibilities to master new training methods and to identify training potentiality of athletes. Ill. 6, bibl. 6, tabl. 1 (in English; abstracts in English and Lithuanian).

G. Dervinis, K. Šarkauskas, V. Grigas, R. T. Toločka. Valdomas hidraulinis irklavimo treniruoklio apkrovos mazgas // *Elektronika ir elektrotechnika.* – Kaunas: Technologija, 2011. – Nr. 10(116). – P. 59–62.

Sukonstruotas akademinio irklavimo treniruoklio irklo apkrovos mazgas. Remiantis eksperimentinių tyrimų ir kompiuterinio modeliavimo rezultatais, sukurtas įtaisas, imituojantis irkluojant vandenyje gaunamą apkrovą. Apkrova imituojama naudojant valdiklio valdomą reguliuojamąjį vožtuvą, keičiantį angos skerspjūvio plotą. Irklo padėčiai nustatyti naudojami trys enkoderiai ir valdiklis su atitinkama atvaizdavimo ir signalizacijos sistema, leidžiančia gerokai praplėsti treniruoklio naudojimo galimybes, įsisavinant naujas treniravimo metodikas ir nustatant sportininkų treniruotumą. Il. 6, bibl. 6, lent. 1 (anglų kalba; santraukos anglų ir lietuvių k.).