

Experimental investigation of vibrational drilling

M. Ubartas*, V. Ostasevičius**, S. Samper***, V. Jūrėnas****, R. Daukševičius*****

*Kaunas University of Technology, Studentų str. 65, 51367 Kaunas, Lithuania, E-mail: martynas.ubartas@ktu.lt

**Kaunas University of Technology, Studentų g. 65, 51367 Kaunas, Lithuania, E-mail: vytautas.ostasevicius@ktu.lt

***Polytech'Annecy-Chambéry, 74944 Annecy Le Vieux Cedex, France, E-mail: serge.samper@univ-savoie.fr

****Kaunas University of Technology, Kęstučio str. 27, 44312 Kaunas, Lithuania, E-mail: vytautas.jurenas@ktu.lt

*****Kaunas University of Technology, Studentų str. 65, 51367 Kaunas, Lithuania, E-mail: rolanas.dauksevicus@ktu.lt

crossref <http://dx.doi.org/10.5755/j01.mech.17.4.563>

1. Introduction

Higher productivity and better surface quality are the prerequisites for current machining industry to be more competitive since modern manufacturing processes require shorter production time and higher precision components. Field of metal machining is closely linked to different industrial sectors including automotive, construction, aerospace, transport, medical, mechanical engineering, etc. Material treatment using cutting is still one of the predominant technological processes for manufacturing high-precision and complex components [1, 2]. Cutting force and speed, feed-rate, temperature in the contact zone are those key variables that significantly influence surface quality and tool life [3, 4]. Control of these parameters affects the entire manufacturing process. Constant pursuit for more effective cutting methods revealed that machining quality can be improved if the tool is assisted with ultrasonic frequency vibrations, i.e. small-amplitude (typically 2-20 μm) and high-frequency (typically up to 20 kHz) displacement is superimposed onto the continuous cutting motion of the tool. During the resulting *vibration(al) cutting* process [5] the tool periodically loses contact with the chip or leaves the workpiece entirely. As a result, machining forces, friction and temperature in the cutting zone decrease, thinner chips are generated, formation of micro-cracks on the cutting edge and workpiece surface is impeded as opposed to the case of conventional machining. This, in turn, leads to enhanced cutting stability, surface finish and form accuracy as well as extended tool life and near-zero burr compared to conventional processes [6]. Surface quality can be improved to such an extent that it may enable complete turning, milling, boring and other cutting processes; (b) according to estimations the waste constitutes about 10% of all the material produced by machining industry [7].

In works [8, 9] it was reported that vibrational turning and milling processes are more effective with respect to traditional methods and the resulting surface quality of the workpiece is markedly improved. L.B. Zhang in his work [10] concluded that at the same cutting conditions, the thrust and the torque during vibrational drilling are reduced by 20-30% when compared to conventional process. V. Ostasevicius et al. in their recent research work [1] proposed a feasible solution for improvement of surface quality of the workpiece in vibrational turning by virtue of advantageous application of the specific higher vibration mode of the cutting tool.

Vibrational cutting technology has already matured to an extent which is sufficient for several limited

industrial applications. However, the understanding of fundamental mechanisms participating in the associated machining processes is still incomplete. Therefore, vibrational cutting still remains a topic of active scientific research since substantial efforts are required in order to develop reliable computational models that would allow optimization of the processes for specific materials and operating conditions.

Promising results obtained during research of vibrational turning and milling processes [1, 8, 9] encouraged the authors of this paper to focus on drilling since it is one of the most common machining processes due to the need for component assembly in mechanical structures.

This paper presents results of experimental investigation of vibrational drilling, which was carried out by using a prototype of tool holder that was developed at Kaunas University of Technology [11]. Reported research results indicate that vibrational drilling process is characterized by reduced axial cutting force and torque in comparison to the traditional drilling. It is demonstrated that control of tool vibration mode through application of appropriate excitation frequency enables to maximize the degree of reduction of surface roughness as well as axial cutting force and torque.

3. Experimental setup

Vibrational drilling experiments were carried out at the Laboratory of Systems and Materials for Mechatronics (SYMME) of the University of Savoie (France) by using CNC milling machine YANG SMV-600 with workpieces made of steel C48. The experiments were performed with the developed vibrational drilling tool (Fig. 1) that employs piezoceramic rings implemented in the tool holder for generating ultrasonic vibrations of the drill cutting edge 10 [11]. A piezoelectric transducer is the source of mechanical oscillations, which transforms the electrical power received from the power supply. The power is supplied to the drill device through collector rings 4. Ultrasonic power supply generates up to 200 W with sinusoidal waveform. A stack of two piezoelectric rings 8 converts the electrical power into mechanical vibrations. A concentrator 9 is fitted onto the end of the transducer, which leads to intensification of drill-tip vibration amplitude that may reach up to 20 μm . The vibrational drilling tool is designed to operate in the resonance mode.

Vibrational drilling experiments were conducted by exciting the tool with the two first resonant frequencies. They were determined by means of tool frequency response measurements that were performed by using experimen-

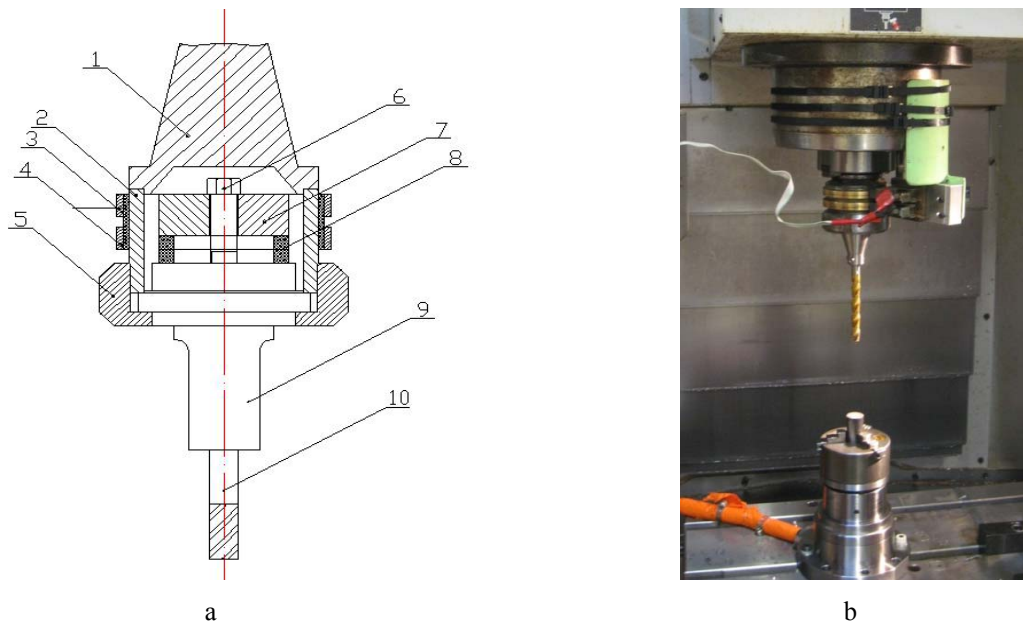

Fig. 1 (a) Structure of vibrational drilling tool: 1 – standard holder (Weldon) DIN 6359, 2 – cylinder, 3 – textolite cylinder, 4 – collector rings, 5 – nut, 6 – bolt, 7 – collet, 8 – piezoceramic rings, 9 – concentrator, 10 – drill. (b) Photo of prototype of vibrational drilling tool mounted on the CNC milling machine

tal setup presented in Fig. 2. Vibrations were registered through acceleration sensor KD-91 ($k = 0.5 \text{ mV}/(\text{m}/\text{s}^2)$), which was fixed on the drill-tip (position A in Fig. 2). The obtained signal was converted and transmitted to the computer via analog-digital converter (digital oscilloscope PICO 3424). PicoScope software was used for processing and visualization of results (Fig. 3).

4-component dynamometer platform KISTLER 9272 was used for measuring the magnitudes of axial cutting force and torque that are generated during the drilling process (Fig. 4). Cylindrical workpieces were mounted on

Table
Main characteristics of the vibrational drilling tool

Specification	Value
Excitation power	200 W
Resonant frequencies	12.0 kHz, 16.6 kHz
Horn material	Steel
Twist drill diameter	10 mm
Maximum amplitude	20 μm

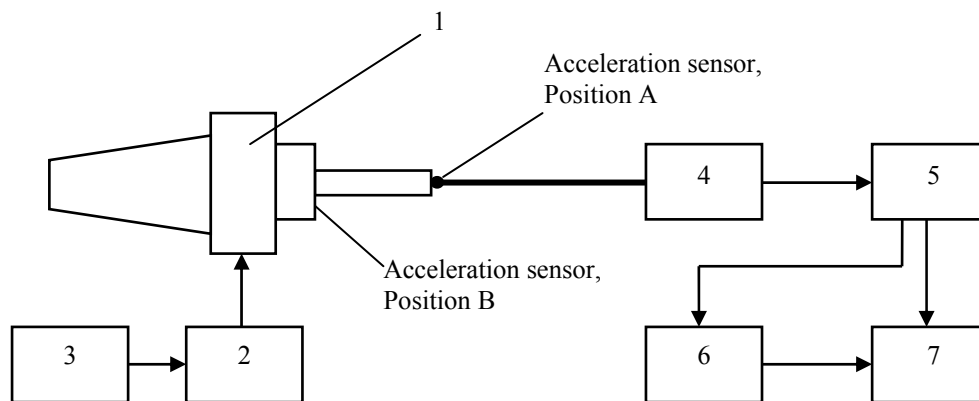

Fig. 2 Experimental scheme for measurement of vibrations generated at the drill-tip (Position A) and at the end of the concentrator (Position B): 1 – vibrational drilling tool; 2 – power amplifier EPA-104; 3 – signal generator ESCORT EGC-3235A; 4 – piezoelectric acceleration sensor KD-91; 5 – sensor controller “Polytec OFV-5000”; 6 – analog-digital converter “PICO ADC3424”; 7 – computer

the clamping device of the dynamometer, while the latter was installed on the desk (Fig. 5). The energy from the high-frequency generator (Fig. 6) was transmitted to the drill. Cutting force and torque during drilling operations were measured, registered, the signal was transmitted to the computer, where a special software developed by CTDEC (Centre Technique de l'Industrie du Décolletage (France)) was used for signal analysis.

4. Testing procedure

Measured amplitude-frequency characteristic (Fig. 3) indicates two main resonances at the excitation frequencies of 12 kHz and 16.6 kHz for the twist drill of $\varnothing 10 \text{ mm}$. These frequencies were applied for tool excitation during vibrational drilling experiments (Fig. 4), which were carried out by using the following regimes: drilling

depth – 15 mm, feed-rate – 0,2-0,25 mm/r, drilling speed – 600-900 r/min. Analogous experiments were repeated for the case of conventional drilling process. For each different

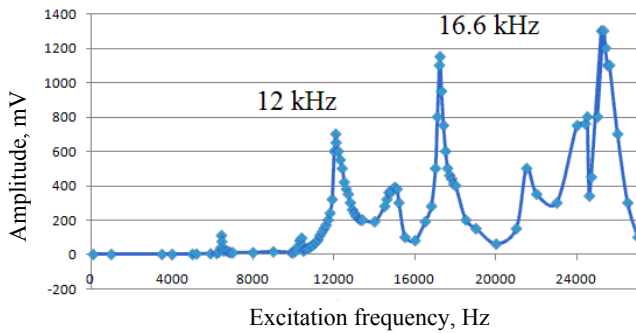

Fig. 3 Measured frequency response of the drilling tool

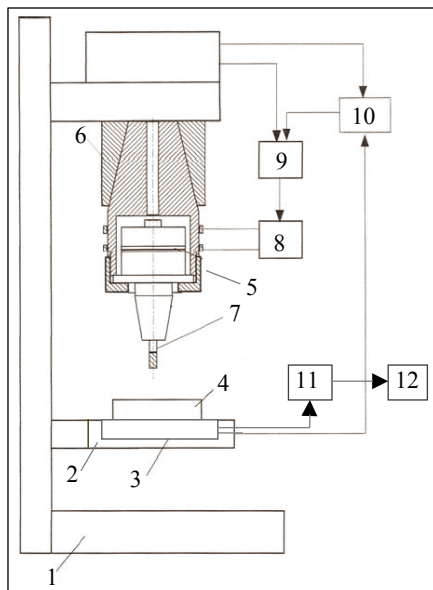

Fig. 4 Scheme of experimental setup for cutting force and torque measurements: 1 – machine construction, 2 – desk, 3 – KISTLER dynamometer platform, 4 – workpiece, 5 – vibrational drilling tool, 6 – standard tool holder, 7 – drill, 8 – high-frequency generator, 9 – controller, 10 – power amplifier, 11 – controllers (KISTLER amplifier), 12 – computer



Fig. 5 Multi-component dynamometer KISTLER 9272 with clamping device mounted atop and cylindrical workpiece fixed in the chuck



Fig. 6 Photo of measurement setup (Fig. 4) used for vibrational drilling experiments (high-frequency generator, power amplifier, KISTLER platform controller and power amplifier, computer)

cutting condition two drilling holes and cutting force/torque measurements were performed. For each feed and cutting speed ratings three force/torque measurements were performed. Obtained experimental results are provided in Figs. 7-8.

5. Analysis of results

Variation of axial cutting force and torque presented in Figs. 7 and 8 respectively demonstrate the comparison between conventional drilling and the vibrational drilling at the first resonant frequency of 12 kHz in the case of three different feed-rates. These characteristics reveal insignificant difference between magnitudes of axial cutting force and torque for conventional and vibrational drilling processes.

Variation of axial cutting force and torque presented in Figs. 9 and 10 respectively provide the comparison between conventional drilling and vibrational drilling at the second resonant frequency of 16.6 kHz. Obvious difference in force and torque magnitudes is observed in this case. Compared with conventional drilling, the cutting force during vibrational drilling decreases by 12-46%. Meanwhile torque measurements at the second resonant frequency indicate reduction of 13-20%. The most pronounced difference between force and torque magnitudes in conventional and vibrational drilling is detected at the

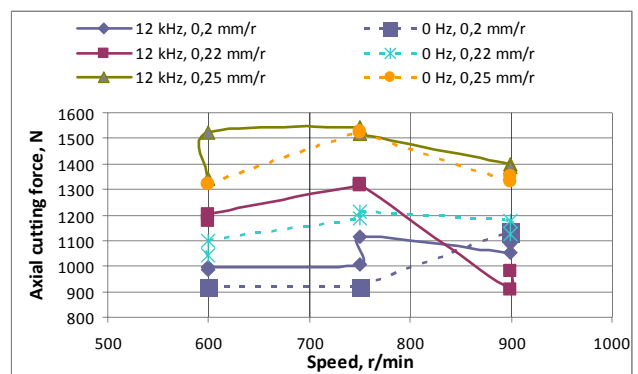

Fig. 7 Variation of axial cutting force vs. drilling speed for three different feed-rates during conventional and vibrational drilling processes when the tool is excited with the first resonant frequency of 12 kHz

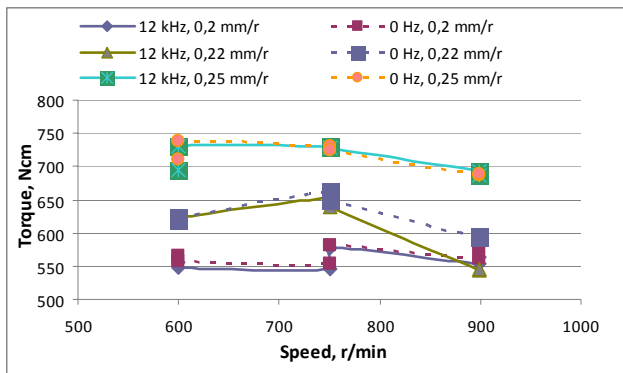

Fig. 8 Variation of torque as a function of drilling speed for three different feed-rates during conventional and vibrational drilling processes when the tool is excited with the first resonant frequency of 12 kHz

largest feed-rate of 0.25 mm/r, meanwhile the least pronounced difference is observed at the smallest feed-rate of 0.2 mm/r. These measurement results for axial cutting force and torque unambiguously demonstrate the importance of tool vibration mode control in vibrational drilling process, i.e. positive effect of superimposed high-frequency vibrations is intensified when higher vibration mode is excited in the tool at a larger driving frequency of the piezoelectric transducer.

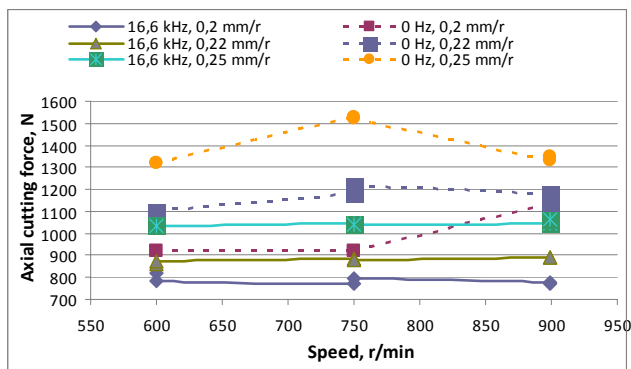

Fig. 9 Variation of axial cutting force as a function of drilling speed for three different feed-rates during conventional and vibrational drilling processes when the tool is excited with the second resonant frequency 16.6 kHz

After drilling experiments the machined cylindrical workpieces were subjected to roughness measurements by using roughness tester TIME TR2001. Workpiece roughness R_a , obtained when drilling at excitation frequency of 12 kHz, is lower approximately by 10% in comparison to the case of conventional drilling (reduction of R_a from 1.7 μm to 1.45 μm). After vibrational drilling at the second resonant frequency of 16.6 kHz the workpiece surface roughness decreased by down to 25% (from 1.7 μm to 1.2-0.98 μm) with respect to conventional drilling. It is obvious that tool excitation at the first resonant frequency insignificantly influences workpiece quality. Transverse vibrations are damped at the contact point between the tool and the workpiece – the longitudinal vibration amplitude is not sufficiently high in this case. At the excitation frequency of 16.6 kHz torsional and longitudinal vibration amplitudes become maximum and the influence on the

workpiece surface quality is much more pronounced. Thus, these experimental findings reveal that in terms of surface roughness the positive effect of vibrational drilling is also enhanced when the tool is excited with higher vibration mode.

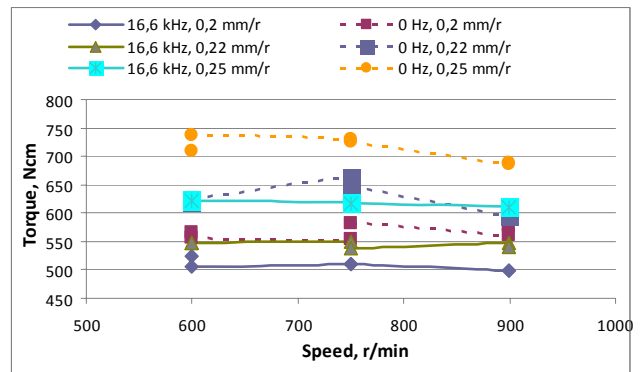

Fig. 10 Variation of torque as a function of drilling speed for three different feed-rates during conventional and vibrational drilling processes when the tool is excited with the second resonant frequency of 16.6 kHz

Drill-tip vibration (time response) measurements were also performed in order to gain a deeper insight into dynamic tool behavior, which could explain the results obtained during drilling experiments. Tool vibrations were measured by means of two acceleration sensors KD-91 ($k=0.5 \text{ mV}/(\text{m}/\text{s}^2)$). For these measurements a particular scheme (Fig. 2, position A) was used: two single-axis acceleration sensors were fixed on the drill-tip (Fig. 11). The registered signals were converted and transmitted to the computer via PICO 3424 digital oscilloscope, where PicoScope software was used for analysis of results.



Fig. 11 Vibrational drilling tool with two acceleration sensors mounted on the drill-tip

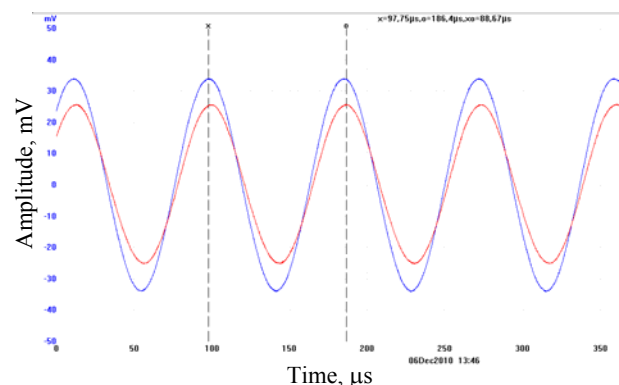

Fig. 12 Measured time response of drill-tip during tool excitation at 12 kHz frequency

For the case of tool excitation at the first resonant frequency (12 kHz) signal curves are almost concurrent, which indicates that the tool undergoes both longitudinal and transverse vibrations (Fig. 12). During tool excitation at the second resonant frequency (16.6 kHz) signal curves are moving in different directions at the same time, thereby revealing that two single-axis sensors register torsional vibrations (Fig. 13). Excitation at 16.6 kHz induces both torsional and longitudinal vibrations in the tool.

Another series of time response measurements were performed with the purpose to evaluate how tool holder generates and transfers vibrations to the drill. In this case the second acceleration sensor was fixed at the end of the concentrator (Fig. 2, position B).

Measurement results are provided in Figs. 14, 15. At the excitation frequency of 12 kHz, the drill excitation

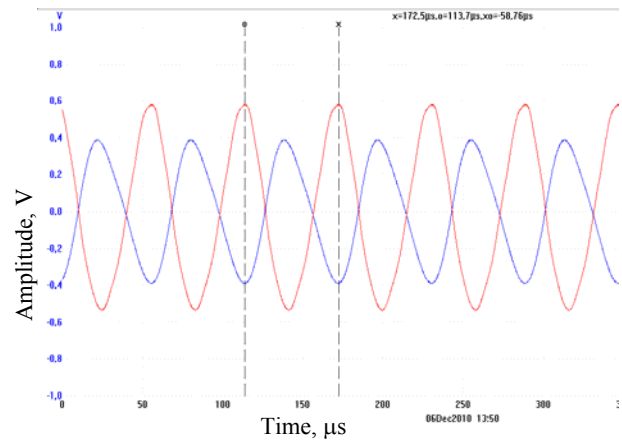

Fig. 13 Measured time response of drill-tip during tool excitation at 16.6 kHz

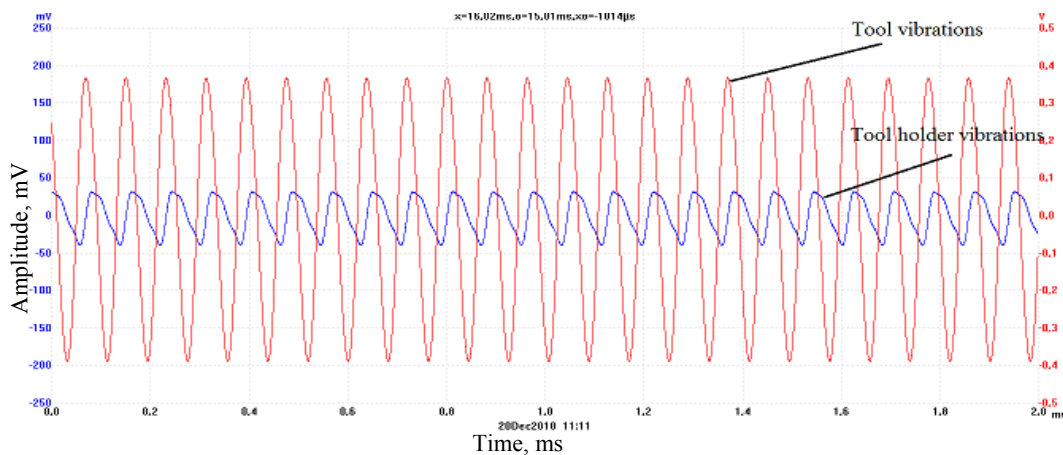

Fig. 14 Measured time response of drill-tip (tool) and tool holder during tool excitation at 12 kHz frequency

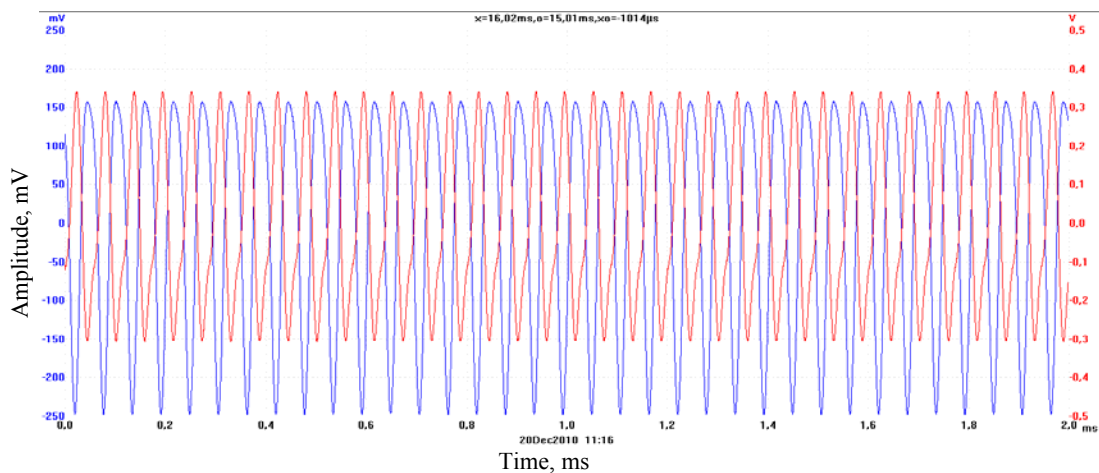

Fig. 15 Measured time response of drill-tip and tool holder during tool excitation at 16.6 kHz frequency

amplitude becomes maximum, but tool holder amplitude stays relatively low (Fig. 14). In contrast, at the excitation frequency of 16.6 kHz, drill excitation amplitude becomes maximum as well as the response of the tool holder, measured at the end of the concentrator. During vibrational cutting process drill vibrations are damped at the contact point between the tool and workpiece therefore the energy transferred from the tool holder may be insufficient.

At the excitation frequency of 16.6 kHz, drill excitation amplitude becomes maximum and the tool holder excitation reaches peak value as well. At the second resonant frequency the drilling tool transfers the highest energy

to the drill, thereby leading to the largest positive influence of vibration drilling.

5. Conclusions

1. Testing revealed that surface roughness during vibrational drilling decreased up to 25% when compared to conventional drilling.

2. At the first resonant frequency (12 kHz) no appreciable vibrational drilling influence was observed with respect to conventional drilling. During tool excitation at the second resonant frequency (16.6 kHz) a significant

reduction of cutting force was observed: axial force decreased in the range of 12-46%, and the torque – 13-20%.

3. At the excitation frequency of 16.6 kHz the tool executes torsional and longitudinal vibrations, which results in maximal reduction of both cutting force and torque as well as workpiece surface roughness. Excitation at this frequency allows to transmit the highest amount of energy from the tool holder to the drill. This manifests in the highest observable positive effect of the vibration drilling.

Acknowledgments

This research was funded by a grant (No. MIP-113/2010) from the Research Council of Lithuania. The authors also express their gratitude for the support of the EGIDE young researchers assistance program.

References

1. **Ostaševičius, V., Gaidys, R., Rimkevičienė, J., Daukševičius, R.** 2010. An approach based on tool mode control for surface roughness reduction in high-frequency vibration cutting, *Journal of Sound and Vibration* 329: 4866-4879.
2. **Bargelis, A., Mankute, R.** 2010. Impact of manufacturing engineering efficiency to the industry advancement, *Mechanika* 4(84): 38-44.
3. **Aouici, H., Yallese, M.A., Fnides, B., Mabrouki, T.** 2010. Machinability investigation in hard turning of AISI H11 hot work steel with CBN tool, *Mechanika* 6(86): 71-77.
4. **Fnides, B., Yallese, M.A., Aouici, H.** 2008. Hard turning of hot work steel AISI H11: Evaluation of cutting pressures, resulting force and temperature, *Mechanika* 4(72): 59-73.
5. **Kumabe, J.** 1979. *Vibration Cutting*. -Tokyo: Jikkyo Publishing,
6. **Brehl, D.E., Dow T.A.** 2008. Review of vibration-assisted machining, *Precision Engineering* 32: 153-172.
7. **Sharma, V.S., Dogra, M., Suri, N.M.** 2008. Advances in the turning process for productivity improvement – A review, *Proceedings of the Institution of Mechanical Engineers, Part B: Journal of Engineering Manufacture* 222(11): 1417-1442.
8. **Rimkevičienė, J., Ostaševičius, V., Jurėnas, V., Gaidys, R.** 2009. Experiments and simulations of ultrasonically assisted turning tool, *Mechanika* 1(75): 42-46.
9. **Graževičiūtė, J., Skiedraitė, I., Jurėnas, V., Bubulis, A., Ostaševičius, V.** 2008. Applications of high frequency vibrations for surface milling, *Mechanika* 1(69): 46-49.
10. **Zhang, L.-B., Wang, L.-J., Liu, X.-Y., Zhao, H.-W., Wang, X.** 2001. Mechanical model for predicting thrust and torque in vibration drilling fibre-reinforced composite materials, *International Journal of Machine Tools & Manufacture* 41: 641-657.
11. **Jurėnas, V., Skiedraitė, I., Bubulis, A., Graževičiūtė, J., Ostaševičius, V.** Tool holder with ultrasonic transducer. Lithuanian patent No. 5586.

M. Ubartas, V. Ostaševičius, S. Samper, V. Jurėnas, R. Daukševičius

VIBRACINIO GRĘŽIMO EKSPERIMENTINIS TYRIMAS

R e z i u m ė

Straipsnyje aprašomiems vibracinio gręžimo eksperimentinis tyrimas. Nustatyti gręžimo įrankio rezonansiniai virpesių dažniai. Atlikti ašinės pjovimo jėgos, momento bei ruošinių paviršiaus kokybės matavimai. Rezultatai palyginti su įprasto gręžimo metu gautais duomenimis.

M. Ubartas, V. Ostasevicius, S. Samper, V. Jurenas, R. Dauksevicus

EXPERIMENTAL INVESTIGATION OF VIBRATIONAL DRILLING

S u m m a r y

During experimental study of vibrational drilling resonant frequencies of the developed tool were evaluated as well as drilling experiments were performed including measurements of cutting force, torque and surface quality, which indicate improvement with respect to conventional drilling and confirm that vibrational drilling can be successfully applied for process efficiency enhancement.

Received January 04, 2011

Accepted June 30, 2011