

Hierarchical Control Approach for Autonomous Mobile Robots

T. Prosevcicius, A. Bukis

*Department of Process Control Technology, Kaunas University of Technology,
Studentu str. 48-111, LT-51367 Kaunas, Lithuania, phone +370 602 10302, e-mail: tomas.prosevcicius@gmail.com*

V. Raudonis

*Department of Control Technology, Kaunas University of Technology,
Studentu str. 48-111, LT-51367 Kaunas, Lithuania, e-mail: vidas.raudonis@ktu.lt*

M. Eidukeviciute

*Department of Theoretical Mechanics, Kaunas University of Technology,
Kestucio str. 27-406, LT-44312 Kaunas, Lithuania, e-mail: marija.eidukeviciute@ktu.lt*

Introduction

The first robots were used for industrial purposes and usually as programmable multifunctional manipulators, able to move details and tools or performing various specific programmed tasks. Robot technology involves electronics, information technology, mechatronics and design. Thus the design of a mobile robotic system is a difficult and complex task due to its interdisciplinary nature and real-time operation related requirements. In order to create and develop an efficient autonomous mobile robot various knowledge are required: machinery design, control theory [1, 2], micro electronics, software programming, and artificial intelligence [3]. Modern intelligent multifunctional autonomous mobile robots are intended to use not only in industry but also in household (e.g., iRobot Scooba® floor washing robot, the iRobot Dirt Dog® shop sweeping robot, the iRobot Verro™ pool cleaning robot or the iRobot Looj™ gutter cleaning robot).

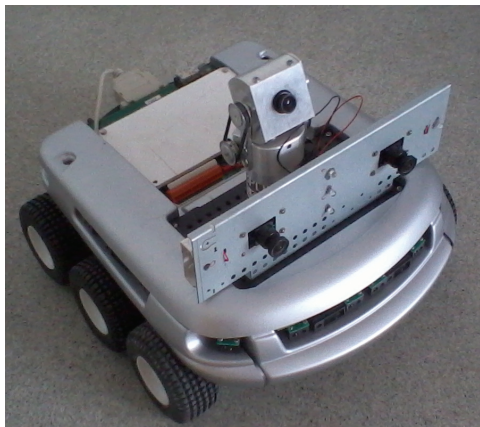

Fig. 1. The example of autonomous mobile robot

An autonomous mobile robots is required to possess many features. Despite increasing advance in robotics technology, the main problem in developing of autonomous mobile robots remains creation of efficient decision making and control algorithms.

Autonomous mobile robots

Mobile robots are characterized by their ability to move freely in the space (Fig. 1). They are provided with specific system which allows them to get to specific location of the closed space by freely chosen or predefined route. Sensors provide information about robots condition and ambient environment. Also visual sensors, colour video cameras can be used, as they help to restore 3D image and helps robot easier navigate in surrounding environment. Mechanical condition is monitored to protect the robot and avoid emergency situations. External sensors allows robot to evaluate environment, distinguish its static and changing parts and to adjust its actions. This information allows making decision how robot will react to environment, adapt to it or even change it by carrying out specific actions with manipulator or work device.

Autonomous robot's controlled modules which carry out autonomous functions on the base of information obtained from sensors control the driving equipment in the way that ensures robot to move towards appointed target avoiding obstacles.

Data acquisition and transfer is another essential ability of the robot. This is used to deliver new task, correct the old one or to send additional information about the environment. If task is performed by several robots, they must communicate in order to achieve the wanted result. Protocol or protocol layer related to specific format data is referred as application layer or application protocol. Such protocol is considered as main. It is the main

interface with the robot and this protocol ensures data transfer.

Application protocol depends on network protocol. One of the most frequently used protocols in the modern robots projects is Ethernet. Simple connections reach the speed of 100 Mbps. Inexpensive wireless Ethernet (802.11) is ideal for mobile robot technology. Usually robots have several protocols and networks. It is important that protocol applied to the robot would support monitoring and control of robot's functions and would do it efficiently. Protocol also should support software debugging, error detection and exclusion functions.

Some sources [4] define three main types of control architecture. In hierarchical type, the motion control level (lowest level) is served by the controllers. The higher level control tasks (user interface, external sensors interface, data storage, trajectory planning, gait generation, high-level motion calculations, etc.) are performed by the host. In the second type of architecture, referred as strict centralized type, all control tasks are determined by one host unit and only the interface cards are used for connection with motor electronics and for interfacing internal sensors. Tasks coordination and processor time sharing must be evaluated by the programmer. The last type is distributed system consisting of the network of equal processing units (e. g. advanced motion controllers or PC), where all units are involved mainly in similar task of motion control of one or several motors. Tasks distribution is almost equal to each unit and motion coordination is obtained not high central control but by the distributed rules (over those system components) of information exchange between the units.

One of the most important tasks is localization task [5, 6]. If robot cannot identify its current location, it cannot foresee further movement. The location is usually defined by relative or absolute coordinates x and y and rotation direction. Global localization (positioning) problem is more complex comparing with tracing as robot must localize itself without initial coordinates. Usually autonomous robots localize themselves by defining space in which they move. The information of location of other static objects can be used as reference points. The robots can also localize themselves using various types of maps or even map the territory themselves. This is referred as synchronous position detection and mapping. The main task of control system in this case is to compare current plan/model with the real environment.

The control of evolutionary [7, 8] autonomous mobile robots usually is performed by themselves. On the base of abilities gained during training or evolution they are able to control their motors, drives, manipulators and work devices. They can show initiative and can act in order to achieve the result. Thus there is no need for separate programs in every particular condition as only specific separate actions are programmed such as taking and lifting an object. Controllers interpret (transform) signals sent by sensors and decide the robot behaviour.

Fig. 2 suggests higher level control system. PC host implements processes responsible for different tasks. They communicate between each other only when specific event occurs. To the lowest level of this system belongs communication with the motor controllers (driver's

process). It gets information form the motion process which defines robots gait and gets calculations to form robot's movement. Brain process gets the main data from the sensors and is responsible for general navigation using the information about current and actually demanded position.

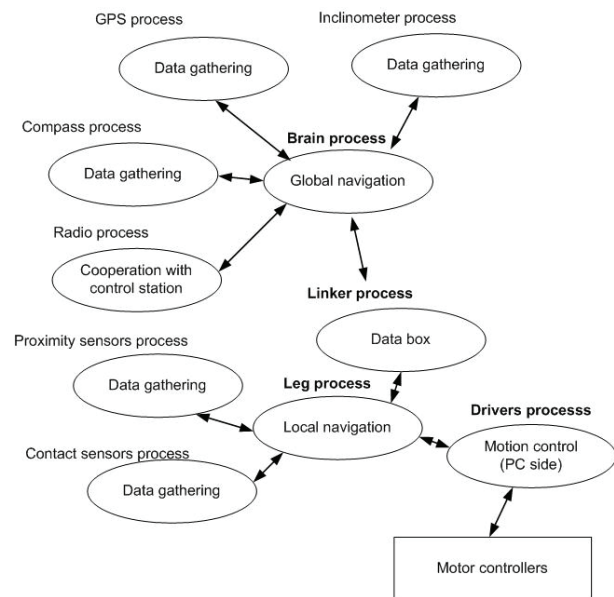

Fig. 2. The structure of robots' higher level control system [4]

In mobile robots technology also behaviour based control system is applied. Robot usually uses several simple behaviours such as: moving along the wall, moving towards the light, tracing monochromatic line or moving object. General behaviour of the robot reveals when these simple behaviours interact with environment of the robot. Simple behaviour is realized in separate parts of the control systems and coordination mechanism is responsible for the control of the behaviours i.e. their actuation and deactivation on particular time in particular situation. Coordination can be carried out using competition or cooperation methods. In case of competition method only behaviour is activated and only it can operate the motors and in case of cooperative method, the motors can be influenced by several behaviours. The quantity and character of initial characteristics depends on environment in which robot operates and its objectives (tasks). In case of behaviour based control system.

Artificial intelligence (AI) helps robot adapt to new environment with minimum training. AI usually uses expert systems and neural networks. Expert system includes programs for computers which aim to understand true-life situations in order to make appropriate decisions. Fuzzy logic can be used to control reactive behaviour of the mobile robot. The reactive behaviour itself is formulated by fuzzy sets and fuzzy rules, and fuzzy reasoning coordinates the conflicts and competition among different types. Neural networks are used in case when the aim is to induce system's self learning with incomplete data in order to achieve its ability to generalize and apply obtained knowledge under new circumstances. Control system based on neural networks learns to form connections between inputs of sensor signals and motors operation. The behaviour of the robot also can be modelled

in virtual environment and this approach is cheaper, the training is more efficient, there is no need to send data to central computer, and even the basic training itself can be done without the robot itself.

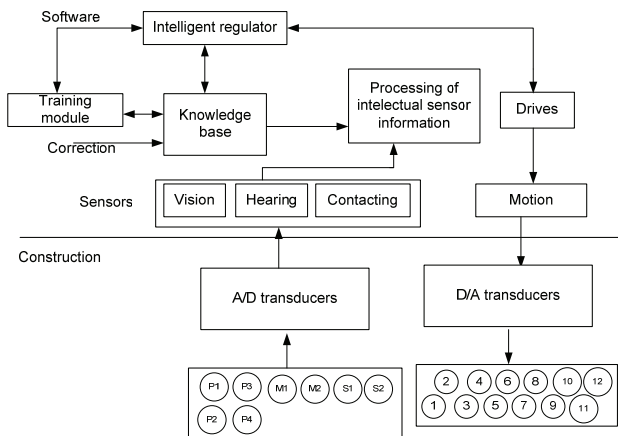

Fig. 3. Intelligent control scheme [9]

Fig. 3 depicts intelligent control scheme [9]. Here the gathered data is converted to signals. The main sensors are video cameras (vision), sound sensors (hearing), and infrared sensors (contacting environment). This data is stored in data base, which enables robot's self-learning and correction of the errors. The main calculations are carried out by intelligent regulator. This regulator is able to organize the whole operating system of the robot. As robot moves, it is dynamical object, thus drives are important as they are directly controlled by intelligent regulator.

Control hierarchy of autonomous mobile robots

When the environment in which robot operates is relatively constant and predictive hierarchical [10, 11, 12, 13] planning methodology can be used. In this case planning module which is in the highest control level determines objectives and control criteria defining the spatial orientation of the robot, and in the navigator which belongs to the lower control level forms robot's movement plan considering limits provided by task planning module and transfers it to the pilot. Step by step it realizes the route determined by navigator by avoiding obstacles. That is control algorithms are based on functions coordination when the environment is not sufficiently defined and control is based on information generated by robot sensors and relation to environment.

In order to carry out more complex tasks robot uses more signals which are transferred through wires and thus more energy is consumed. In order to simplify and speed up control system of the robot hierarchical control system could be used. This paper reviews hierarchical level structure (see Fig. 4) suggested by. Functional relationship between robot's hierarchical control system modules and links.

The first hierarchical level (the lowest) determines the movement of the robot. It involves of the drive motor, sensors and operating device. The characteristics determined in this level define dynamical characteristics of the robot. The activity in this hierarchical level is minimum initial information such as obstacle detection,

map composing. Other four hierarchical levels are implemented in computers (servers).

The second hierarchical level is a level of elementary operations which are decomposed into finite actions. In this level operations are executing according program, its functioning is corrected according information obtained from the sensors. The second level selects necessary programme parts for executing particular actions. In the second hierarchical level movement parameters are calculated, if the obstacle is detected the command to avoid it is executed.

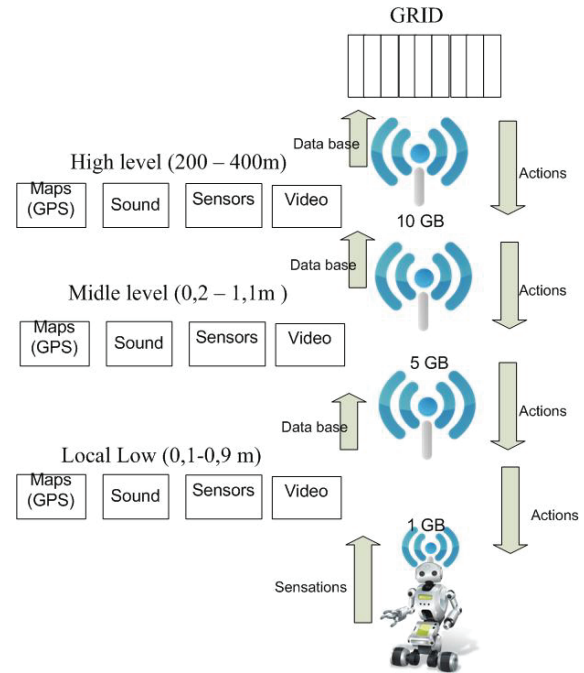

Fig. 4. Hierarchical control system

The third hierarchical level - elementary operations into which any finite operation can be decomposed. In this level by synthesizing operations environment is also evaluated. In this level not only visual information can be used, but also any other information stored in the robot. In the third level operation components of separate actions are synthesized. For example if robot detects the obstacle and manages to avoid it, later it can foresee next obstacle.

The fourth hierarchical level performs synthesis of functional finite complex actions. Here robot and operator interact. Complex task is decomposed into the sequence of elementary typical operations realized by first three hierarchical levels. Operator issues directives for the robot using its language. Here interactive mode is possible when robot queries for additional data or approach the operator itself for instructions to perform operations or in case of emergency or abnormal situations

The fifth hierarchical level (the highest) schedules the activities of the robot and forms tasks for lower levels. It sets the sequence of the actions. This level also gathers information about environment and synthesizes appropriate models even considering the description of the environment. This level is responsible for robot as undivided system functioning and involves intelligent development of the system. Thus level implements intellectual properties of the robot and its perfection determines the field of tasks which can be performed

automatically by the robot. That is the level of AI, where tasks and activity field is formed considering ambient conditions.

Conclusions

The reviewed literature suggests hierarchical system five hierarchical levels. Each level will address attributed problems according to its position in hierarchical system. To accelerate the speed of calculations it is suggested to send them to server of correspondent hierarchical level. As mobile autonomous robot is used as prototype all information should be transferred through wireless network. The future aim is to achieve efficient system work by increasing the rate of data transfer between hierarchy levels.

References

1. **Altintas A.** A New Approach to 3–Axis Cylindrical and Cartesian Type Robot Manipulators in Mechatronics Education // *Electronics and Electrical Engineering*. – Kaunas: Technologija, 2010. – No. 10(106). – P. 151–154.
2. **Soltanpour M. R., Shafiei S. E.** Robust Backstepping Control of Robot Manipulator in Task Space with Uncertainties in Kinematics and Dynamics // *Electronics and Electrical Engineering*. – Kaunas: Technologija, 2009. – No. 8(96). – P. 75–80.
3. **McIsaac K.A., Das A.K., Esposito J.M., Ostrowski J.P.** A hierarchical, modal approach to hybrid systems control of autonomous robots. // *Intelligent Robots and Systems*. – 2000. – P. 1020–1025.
4. **Zielinska T.** Control systems of autonomous robots // *Robot Motion and Control*, 2004. – P. 47–51.
5. **Bartkevičius S., Jakas Ž., Šarkauskas K.** Avoidance of Possible Collisions of Mobile Robots // *Electronics and Electrical Engineering*. – Kaunas: Technologija, 2010. – No. 10(106). – P. 105–108.
6. **Baranauskas V., Bartkevicius S., Sarkauskas K.** Creation of vector marks for robot navigation // *Electronics and Electrical Engineering*. – Kaunas: Technologija, 2008. – No. 4(84). – P. 27–30.
7. **Mourioux G., Novales C., Poisson G.** A hierarchical architecture to control autonomous robots evolving in an unknown environment // *Industrial Technology*, 2004. – P. 72–77.
8. **Jong–Hann J., Tien–Pao W.** Robust visual servo control of a mobile robot for object tracking in shape parameter space // *Decision and Control*, 2004. – P. 4016–4021.
9. **Šarkauskas K.** Kompiuterinės mašinų valdymo sistemos. Vilniaus pedagoginio universiteto leidykla, 2008. – 199 p.
10. **Elston J., Frew E.W.** Hierarchical distributed control for search and tracking by heterogeneous aerial robot // *Networks Robotics and Automation*, 2008. – P. 170–175.
11. **Imazeki K., Maeno T.** Hierarchical control method for manipulating/grasping tasks using multi–fingered robot hand // *Intelligent Robots and Systems, IEEE/RSJ International Conference*, 2003. – P. 3686–3691.
12. **Zhixiang T., Hongtao W., Chun F.** Hierarchical adaptive backstepping sliding mode control for under actuated space robot // *Informatics in Control, Automation and Robotics*, 2010. – P. 500–503.
13. **Qingsheng L., Baoling H., Xin M., Kun W., Xingguang D.** A FWN–Based Distributed Hierarchical System for Hexapod Bio–Robot Control // *Intelligent Control and Automation*, 2006. – P. 8943 – 8947.

Received 2011 03 22

T. Prosevičius, A. Bukis, V. Raudonis, M. Eidukevičiūtė. Hierarchical Control Approach for Autonomous Mobile Robots // Electronics and Electrical Engineering. – Kaunas: Technologija, 2011. – No. 4(110). – P. 101–104.

Methods for intelligent mobile robots control which are based on principles of hierarchical control systems will be reviewed in this article. Hierarchical intelligent mobile robots are new direction for development of robotics, which have wide application perspectives. Despite increasing progress in technologies, the main problem of autonomous mobile robots development is that, they are ineffective in their control. In each of the hierarchical control levels (movement in space, problems solving and signal processing sets) will define by specific management of objectives, goals and rules. Communication and management between hierarchies are implemented by higher level of hierarchy using obtained information about the environment and lower level of hierarchy. Studies have shown that artificial neural networks, fuzzy logic are widely used for the development of the hierarchical systems. The main focus of the work is on communications in hierarchy levels, since the robot must be controlled in real time. Ill. 4, bibl. 13 (in English; abstracts in English and Lithuanian).

T. Prosevičius, A. Bukis, V. Raudonis, M. Eidukevičiūtė. Hierarchiniai autonominių mobiliųjų robotų valdymo metodai // Elektronika ir elektrotechnika. – Kaunas: Technologija, 2011. – Nr. 4(110). – P. 101–104.

Šiame straipsnyje apžvelgiami metodai, kurių esmė yra autonominių mobiliųjų robotų valdymui taikomi hierarchinių valdymo sistemų principai. Hierarchiniai autonominiai mobilieji robotai yra nauja robotikos raidos kryptis su plačiomis taikymo perspektyvomis. Nepaisant veržlios pažangos, pagrindinis autonominių mobiliųjų robotų tobulėjimo stabdys ir toliau yra neefektyvus jų valdymas. Kiekvienoje valdymo hierarchijoje (judėjimo erdvės, sprendžiamų uždavinių ir signalų apdorojimo ciklų hierarchijos) bus apibrėžiami specifiniai valdymo uždaviniai ir tikslai. Pasaulyje atlikti tyrimai rodo, kad šioms sistemoms kurti plačiausiai taikomi neuroniniai tinklai, neraiškioji logika. Dėmesio skiriama ir komunikacijoms tarp hierarchijų, nes robotas turi būti valdomas realiu laiku. Il. 4, bibl. 13 (anglų kalba; santraukos anglų ir lietuvių k.).