

## Generalized Mathematical Model of Controlled Linear Oscillating Mechatronic Device

A. Senulis, D. Eidukas

Department of Electronics Engineering, Kaunas University of Technology,  
Studentų str. 50, LT-51368 Kaunas, Lithuania, phone: +370 614 834 68, e-mail: audriussenulis@yahoo.com

E. Guseinoviene

Department of Electrical Engineering, Klaipėda University,  
Bijūnų str. 17, 91225 Klaipėda, Lithuania, phone: +370 46 39 89 54, e-mail: eleonora.guseinoviene@ku.com

### Introduction

The generalized mathematical model of controlled linear oscillating device aspects presented in this paper allows analyzing the system as a linearized automatic control system, evaluating two-mass mechanical system, assuming the equivalent linear load and nonlinear electrical system elements.

There are several ways of building mathematical models for such devices and their control systems:

- Using magnetic field equations [1, 2];
- Analyzing the control of oscillation coordinate in real time [3];
- Presenting a differential forms of the system, but not all the variables are time-dependent [3, 4, 6];
- Evaluating the model by their supply voltage usage and their effect [4];
- The usage of automatic control systems in electropneumatic systems [5];
- Mathematical models by analyzing the magnetical circuit using finite elements [2, 7–9].
- Modeling of fault analysis of the moving part of the mechatronic device [10];

There are a lot of presentations of the separate parts or more complex models which involve one or several parts of the physical model. The paper presents concept of building linearized mathematical model for such devices.

### General system overview and main assumptions

The analysis of the controlled double-sided linear oscillating mechatronic device investigates the double mass double-sided springless linear oscillating electrical motor-compressor (Fig. 1). The investigation of the system could be split in three main subsystems analysis:

- Electrical subsystem analysis;
- Control subsystem analysis;

- Mechanical subsystem analysis.

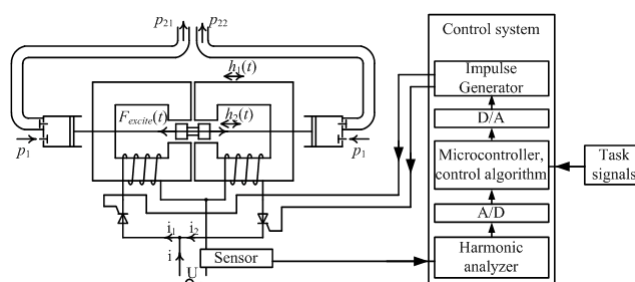

Fig. 1. Block diagram of linear oscillating mechatronic device with control system structure as a controlled double-sided springless linear oscillating electrical motor-compressor

The system mathematical model could be realized by using the mathematical model of such mechatronic device. Due to the oscillating origin of the system there two main regimes to be investigate: a) transient processes (starting the system, change of the load or task signals), b) quasi-stationary processes (when the transient processes are over), which is analyzed in the paper. The assumptions for the mathematical model building are:

- All the variables in the model are time-dependent;
- The mechanical part is a two mass system, with linear equivalent stiffness and damping properties;
- The analysis of the system could be presented by creation of the automatic control system and using transfer function of the subsystems or their parts;
- The real electrical subsystem is not linear (containing: inductance nonlinearity – saturation, which is presented in the paper; thyristor nonlinearity), but is converted to the equivalent linear subsystem;
- The mathematical model of electrical subsystem estimates these parameters – losses in the windings, losses in the magnetic circuit, time-dependent winding inductances and mutual inductance direct voltage drop of

thyristors – assumed 2 V. The neglected parameters – voltage drop in the current feedback resistor  $r_{fbk}$ ;

- The exciting force of the system is nonlinear, but the analysis is simplified by using superposition principal and analyzing the system effect from each force effecting harmonic separately and finally summarizing all the results;

- The oscillations  $h(t)$  of the system is linear, and contains 1<sup>st</sup> harmonic only and a constant component (1) which appears only due to the existence of additional constant external force, the oscillation amplitude is constant in quasi-stationary processes [6, 8, 11]

$$h(t) = H_0 + H'_m \cdot \sin(\omega t + \varphi_h), \quad (1)$$

here  $h(t)$  – oscillation coordinate;  $H_0$  – constant oscillation part;  $H'_m$  – oscillation amplitude (when  $H_0 = 0$ ,  $H'_m = H_m$ );  $\varphi_h$  – oscillation phase;  $\omega$  – oscillation frequency;

- The control system is digital and the controlled algorithm is based on controlling the oscillation of the system only by analyzing the total electrical systems harmonics parameters (harmonic amplitudes and harmonics phases relative to voltage phase). The control system consists of total current feedback, harmonic analyzer; A/D and D/A converters, microcontroller with control algorithm and impulse generator. Some parts already could be involved in the microcontroller architecture.

Finalizing the mathematical model could be presented in the time-dependent differential form or algebraic form and further usage of Laplace transformations and z transformations could be applied.

### The analysis mathematical model of electrical subsystem

The analysis of the mathematical model consists of building an equivalent electrical circuit of the oscillating mechatronic device. There are several possibilities of realizing this circuit, which are presented in Fig. 2. The figure shows that there are two ways to analyze the variation of the inductances or magnetic conductivity – on the basis of oscillation amplitude  $h$  [8, 11, 12] or time  $t$ . The mathematical model presented here will be build by using the variant shown in Fig. 2 a) and using time-dependent variables.

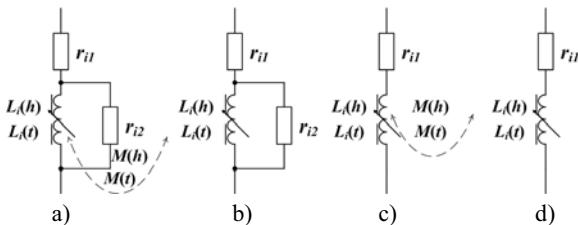

**Fig. 2.** Different types of equivalent winding schemes of linear oscillating mechatronic device: a) losses in winding and magnetic circuit, oscillation-dependent or time-dependent inductance and mutual inductance are estimated; b) mutual inductance is neglected; c) losses in magnetic circuit is neglected; d) mutual inductance and losses in magnetic circuit is neglected

The assumptions mentioned above let's to build the equivalent electrical circuit presented in the Fig. 3. This circuit is similar to the presented in papers [13], but there was no mutual inductance estimation and the inductances were oscillation-dependent [8, 9, 12, 13].

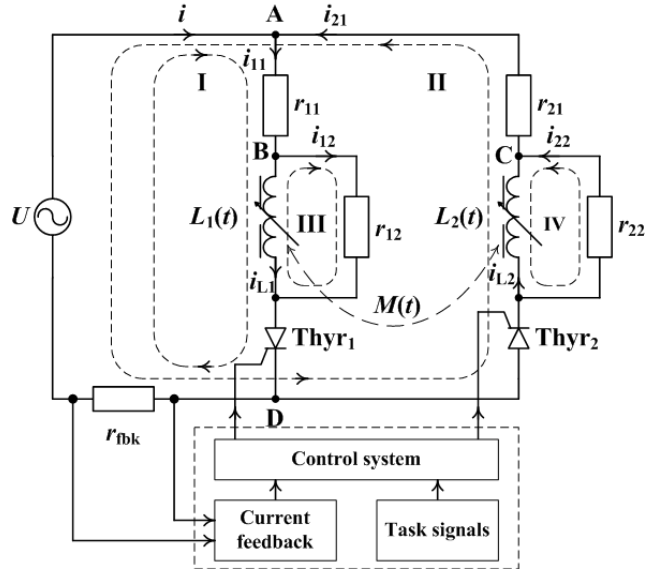

**Fig. 3.** Equivalent electrical diagram of controlled double-sided linear oscillating mechatronic device with the thyristor voltage converter

The primary system (2) build by using Kirchhoff's Laws is presented below:

$$\left\{ \begin{array}{l} i(t) = i_{11}(t) - i_{21}(t), \quad A \\ i_{11}(t) = i_{L1}(t) + i_{12}(t), \quad B \\ i_{21}(t) = i_{L2}(t) + i_{22}(t), \quad C \\ u(t) = r_{11}i_{11}(t) + \frac{d(L_1(t)i_{L1}(t))}{dt} \pm \frac{d(M(t)i_{L2}(t))}{dt} + u_{Thyr1}(t), \quad I \\ u(t) = r_{21}i_{21}(t) + \frac{d(L_2(t)i_{L2}(t))}{dt} \pm \frac{d(M(t)i_{L1}(t))}{dt} + u_{Thyr2}(t), \quad II \\ 0 = r_{12}i_{12}(t) - \left[ \frac{d(L_1(t)i_{L1}(t))}{dt} \pm \frac{d(M(t)i_{L2}(t))}{dt} \right], \quad III \\ 0 = r_{22}i_{22}(t) - \left[ \frac{d(L_2(t)i_{L2}(t))}{dt} \pm \frac{d(M(t)i_{L1}(t))}{dt} \right], \quad IV \end{array} \right. \quad (2)$$

here  $i(t)$  – total current of the circuit;  $i_{11}(t)$  and  $i_{21}(t)$  – currents of the each branch of the circuit;  $i_{L1}(t)$  and  $i_{L2}(t)$  – inductive currents of the each branch;  $i_{12}(t)$  and  $i_{22}(t)$  – currents in branches estimating the magnetic losses;  $L_1(t)$ ,  $L_2(t)$ ,  $M(t)$  – time-dependent inductance of each circuit branch and mutual inductance;  $r_{11}$  and  $r_{21}$  – resistance of each winding;  $r_{12}$  and  $r_{22}$  – equivalent resistance for estimating magnetic losses;  $u(t)$  – supply voltage  $u(t) = U_m \cdot \sin(\omega t)$ ;  $u_{Thyr1}(t)$  and  $u_{Thyr2}(t)$  – voltage drop on thyristors of each branch.

The analysis of the system (2) can be simplified by making these notices:

a) The first equation is independent for making time dependent differential equation and can be calculated separately;

b) The mutual inductance effect is negative.

The differential form of the electrical subsystem after rearrangements would be:

$$\begin{cases} L_1(t) \frac{dL_1(t)}{dt} - M(t) \frac{dL_2(t)}{dt} = - \left( \frac{r_{11}r_{12}}{r_{11} + r_{12}} + \frac{dL_1(t)}{dt} \right) \cdot i_{L1}(t) + \\ + \frac{dM(t)}{dt} i_{L2}(t) + \frac{r_{12}}{r_{11} + r_{12}} (u(t) - u_{Thyr1}(t)), \\ - M(t) \frac{dL_1(t)}{dt} + L_2(t) \frac{dL_2(t)}{dt} = \frac{dM(t)}{dt} i_{L1}(t) - \\ - \left( \frac{r_{21}r_{22}}{r_{21} + r_{22}} + \frac{dL_2(t)}{dt} \right) \cdot i_{L2}(t) + \frac{r_{22}}{r_{21} + r_{22}} (u(t) - u_{Thyr2}(t)). \end{cases} \quad (3)$$

The equation system (3) in the matrix form would be:

$$\mathbf{M}(t) \frac{d\mathbf{x}(t)}{dt} = \mathbf{A}(t) \cdot \mathbf{x}(t) + \mathbf{b}(t), \quad (4)$$

here the matrices of the equation (4) are:

$$\mathbf{x}(t) = \begin{bmatrix} i_{L1}(t) \\ i_{L2}(t) \end{bmatrix}, \quad (5)$$

$$\mathbf{M}(t) = \begin{bmatrix} L_1(t) & -M(t) \\ -M(t) & L_2(t) \end{bmatrix}, \quad (6)$$

$$\mathbf{A}(t) = \begin{bmatrix} - \left( \frac{r_{11}r_{12}}{r_{11} + r_{12}} + \frac{dL_1(t)}{dt} \right) & \frac{dM(t)}{dt} \\ \frac{dM(t)}{dt} & - \left( \frac{r_{21}r_{22}}{r_{21} + r_{22}} + \frac{dL_2(t)}{dt} \right) \end{bmatrix}, \quad (7)$$

$$\mathbf{b}(t) = \begin{bmatrix} \frac{r_{12}}{r_{11} + r_{12}} \cdot (u(t) - u_{Thyr1}(t)) \\ \frac{r_{22}}{r_{21} + r_{22}} \cdot (u(t) - u_{Thyr2}(t)) \end{bmatrix}. \quad (8)$$

The analysis of the differential equation system has several aspects – the nonlinearities of inductances and thyristors influencing the solution. The inductance could be presented in the oscillating amplitude dependent sine form with constant part [6] (Fig. 4 a, in figure the oscillation amplitude is relative):

$$L_1(h(t)) = L_0 + K \sin\left(\frac{h(t)}{H_m} \cdot \frac{\pi}{2}\right), \quad (9)$$

$$L_2(h(t)) = L_0 - K \sin\left(\frac{h(t)}{H_m} \cdot \frac{\pi}{2}\right), \quad (10)$$

here  $L_0$  – constant inductance part assumed in oscillation center. The coefficient  $K$  is equal:

$$K = \frac{L_{\max} - L_{\min}}{2 \sin\left(\frac{\pi}{2}\right)}, \quad (11)$$

here  $L_{\max}$  – inductance of winding, when  $h(t)=H_m$ ;  $L_{\min}$  – inductance of winding, when  $h(t)=-H_m$ .

Assuming the equation (1) equations (9) and (10) could be rewritten in time-dependent form (Fig. 4 b):

$$L_1(t) = L_0 + K \sin\left(\frac{H_0(t) + H'_m(t) \cdot \sin(\omega t + \varphi_h)}{H_m} \cdot \frac{\pi}{2}\right), \quad (12)$$

$$L_2(t) = L_0 - K \sin\left(\frac{H_0(t) + H'_m(t) \cdot \sin(\omega t + \phi_h)}{H_m} \cdot \frac{\pi}{2}\right). \quad (13)$$

(12) and (13) are suitable for transient and quasi-stationary regimes of the oscillating mechatronic device and so the amplitudes  $H_0(t)$  and  $H'_m(t)$  are time variables, but when analyzing quasi-stationary these parameters are constant. The oscillation amplitude  $H_m$  – is the maximum limited oscillation value, which is constant in any process and  $H_0$  part only exist due the constant external force, if not present the part  $H_0$  is neglected. The oscillation amplitude  $H'_m$  – is real oscillation amplitude, which depends on the firing angle of the thyristors, supply voltage value and might be equal or less then  $H_m$ .

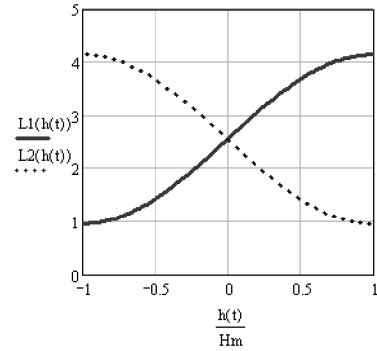

a)

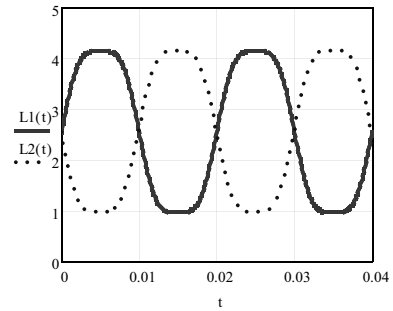

b)

**Fig. 4.** The graphics of motor winding inductance dependence on: a) oscillation coordinate; b) time

The other part of equation (3), which is nonlinear, is the derivative of the inductances of the windings, which equal to:

$$\begin{aligned} \frac{dL_1(t)}{dt} &= \frac{K\pi}{2H_m} \cos\left(\frac{H_0(t) + H'_m(t) \sin(\omega t + \varphi_h)}{H_m} \cdot \frac{\pi}{2}\right) \times \\ &\times \left( \frac{dH_0(t)}{dt} + \frac{dH'_m(t)}{dt} \sin(\omega t + \varphi_h) + \right. \\ &\left. + \omega H'_m(t) \cos(\omega t + \varphi_h) \right), \end{aligned} \quad (14)$$

$$\frac{dL_2(t)}{dt} = -\frac{dL_1(t)}{dt}. \quad (15)$$

Analyzing the quasi-stationary process the equations (12)-(15) could be rewritten:

$$L_1(t) = L_0 + K \sin\left(\left(k(H_0) + k(H'_m) \sin(\omega t + \varphi_h)\right) \cdot \frac{\pi}{2}\right), \quad (16)$$

$$L_2(t) = L_0 - K \sin\left(\left(k(H_0) + k(H'_m) \sin(\omega t + \varphi_h)\right) \cdot \frac{\pi}{2}\right), \quad (17)$$

$$\frac{dL_1(t)}{dt} = \frac{K\pi\omega k(H'_m)}{2} \times \cos\left(\left(k(H_0) + k(H'_m) \sin(\omega t + \varphi_h)\right) \cdot \frac{\pi}{2}\right) \cdot \cos(\omega t + \varphi_h), \quad (18)$$

$$\frac{dL_2(t)}{dt} = -\frac{K\pi\omega k(H'_m)}{2} \times \cos\left(\left(k(H_0) + k(H'_m) \sin(\omega t + \varphi_h)\right) \cdot \frac{\pi}{2}\right) \cdot \cos(\omega t + \varphi_h). \quad (19)$$

The coefficients  $k(H_0)$  and  $k(H'_m)$  represent the relative constant part of oscillations  $H_0$  and oscillating amplitude  $H'_m$  of the oscillating mechatronic device

$$k(H'_m) = \frac{H'_m}{H_m}, \quad k(H_0) = \frac{H_0}{H_m}. \quad (20)$$

These coefficients (20) must obey the rules, which estimate the limitation of oscillation of the moving part of oscillating mechatronic device

$$|k(H_0) + k(H'_m)| \leq 1 \text{ or } |k(H'_m)| \leq 1, \text{ if } k(H_0) = 0. \quad (21)$$

The dependencies (18) and (19) are presented in Fig. 5 b, where in Fig. 5 a) the inductance derivatives dependent from the relative oscillating amplitude are represented. The coefficients (20) in Fig. 5 are assumed:  $k(H_0) = 0$  and  $k(H'_m) = 1$ . The reduction of  $k(H'_m)$  or  $k(H_0) + k(H'_m)$  leads to more linear electrical system in the accordance to the inductance variations of the windings.

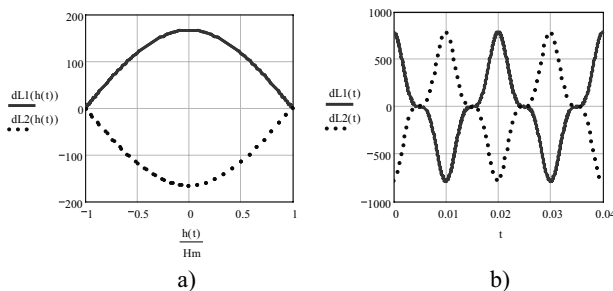

**Fig. 5.** The dependence of motor winding inductance derivative on: a) oscillation coordinate; b) time

The mutual inductance and its derivative which are presented in the equations (2), (3), (6) and (7) are not detailed in this paper because of the variety of the constructions of the magnetic system of oscillating mechatronic, it would require more investigation in the future. As it was shown above in the equations (16)-(17) the time dependent equations are nonlinear and their

Laplace transformation could be produced only by changing the equations the equivalent, which could be transformed. The parts of mentioned equations should be replaced are:

$$k_{\sin}(t) = \sin\left(\left(k(H_0) + k(H'_m) \sin(\omega t + \varphi_h)\right) \cdot \frac{\pi}{2}\right), \quad (22)$$

$$k_{\cos}(t) = \cos\left(\left(k(H_0) + k(H'_m) \sin(\omega t + \varphi_h)\right) \cdot \frac{\pi}{2}\right). \quad (23)$$

The equations (22) and (23) values according (21) varies in range [-1; 1]. The equations could be replaced using known trigonometric functions expansion to series:

$$\sin(z) = z \cdot \prod_{k=1}^{\infty} \left[1 - \left(\frac{z}{k\pi}\right)^2\right], \quad (24)$$

$$\cos(z) = \prod_{k=0}^{\infty} \left[1 - \left(\frac{2z}{\pi(2k+1)}\right)^2\right], \quad (25)$$

here  $z$  the angle or its equation;  $k$  – number of series members. The equations (22) and (23) after the analysis and selection of how many members of the equations (24) and (25) to take into account will take the shape:

$$k_{\sin}(t) = \left(\left(k(H_0) + k(H'_m) \sin(\omega t + \varphi_h)\right) \cdot \frac{\pi}{2}\right) \times \prod_{k=1}^3 \left[1 - \left(\frac{\left(k(H_0) + k(H'_m) \sin(\omega t + \varphi_h)\right)}{2k}\right)^2\right], \quad (26)$$

$$k_{\cos}(t) = \prod_{k=0}^1 \left[1 - \left(\frac{\left(k(H_0) + k(H'_m) \sin(\omega t + \varphi_h)\right)}{2k+1}\right)^2\right]. \quad (27)$$

After the composing of the equations (16)-(19) and equations (26) and (27), the new formulas of inductance and derivatives of inductances become linear and the Laplace transformation could be realized.

The nonlinearity of thyristors depends on the firing angle  $\alpha$  of the thyristors and the dissipation of the magnetic field of the analyzed branch, which could be represented by currents  $i_{1i}(t)$ . If the resistors  $r_{2i}$  would not be taken into account, the representative currents would be  $i_{Li}(t)$ . After the linearization of the thyristor nonlinearity, all the system (3) equations transformed using Laplace transformation.

### The aspects of control subsystem

The control subsystem content was mentioned above and more detailed signal distribution in the feedback is presented in Fig. 6.

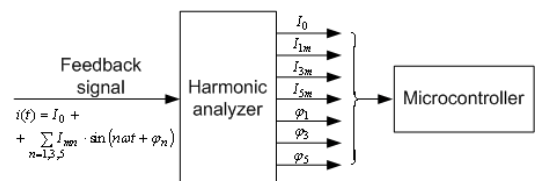

**Fig. 6.** Feedback signal distribution of control system

The microcontroller realizes the control algorithm of oscillation amplitude by using the total current  $i(t)$  first five odd harmonics amplitudes and phases, and also the DC part if present (28)

$$i(t) = I_0 + \sum_{n=1,3,5} I_{mn} \cdot \sin(n\omega t + \varphi_{in}), \quad (28)$$

here  $I_0$  – DC of total current;  $I_{mn}$  –  $n^{\text{th}}$  total current harmonics amplitude;  $n$  – harmonics order;  $\varphi_{in}$  –  $n^{\text{th}}$  total current harmonics phase. The 5<sup>th</sup> order of the harmonics is analyzed assuming the higher harmonics are very small [13]. The harmonic analyzer would work using FFT and algorithm for the current phase extraction.

### The analysis mathematical model of mechanical subsystem

The analysis of the mechanical linear two-mass system is simpler task, than electrical. The Fig. 7 represents the linear mechanical system.

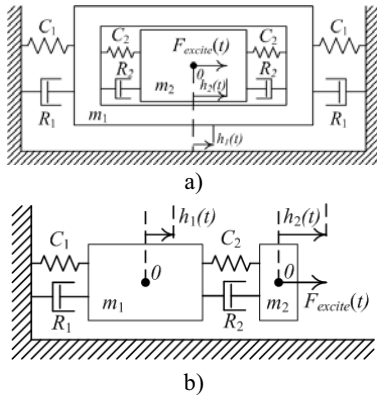

Fig. 7. Equivalent mechanical scheme of double-mass mechatronic device: a – detailed, b – simplified

The two masses system represent: 1 – “stator”, 2 – moving part. Mechanical subsystem parameters are: masses  $m_1$  and  $m_2$ , damper properties - stiffness  $C_1$  and damping coefficient  $R_1$ , equivalent air spring stiffness  $C_2$  and damping properties of friction estimated by damping coefficient  $R_2$ . Analyzing the simplified equivalent mechanical system (Fig. 7 b) the time-dependent differential equation system would be:

$$\begin{cases} m_1 a_1(t) + (R_1 + R_2)v_1(t) - R_2 v_2(t) + \\ + (C_1 + C_2)h_1(t) - C_2 h_2(t) = 0, \\ m_2 a_2(t) - R_2 v_1(t) + R_2 v_2(t) - \\ - C_2 h_1(t) + C_2 h_2(t) = F_{excite}(t), \end{cases} \quad (29)$$

here  $a_1(t)$ ,  $a_2(t)$  – accelerations of oscillations of “stator” and moving part respectively,  $m/s^2$ ;  $v_1(t)$ ,  $v_2(t)$  – velocities of oscillations of “stator” and moving part respectively,  $m/s$ ;  $h_1(t)$ ,  $h_2(t)$  – oscillation coordinates of “stator” and moving part respectively,  $m$ ;  $F_{excite}(t)$  – exciting force of the moving part of mechatronic device,  $N$ .

The exciting force in general form consists of constant external force  $F_0$  and electromagnetic force  $F_{elm}(t)$  of the oscillating mechatronic device. The electromagnetic force also consists of constant part, main and higher odd

harmonics. The estimated higher harmonics are 3<sup>rd</sup> and 5<sup>th</sup>, because the total current (28) equation the highest order of the harmonics are also 5<sup>th</sup>

$$F_{excite}(t) = \pm F_0 + F_{elm}(t) = \pm F_0 + F_{elm.0} + \sum_{n=1,3,5} F_{elm.mn} \cdot \sin(n\omega t + \varphi_{F_{elm.n}}), \quad (30)$$

here  $F_{elm.0}$  – constant part of electromagnetic force;  $F_{elm.mn}$  –  $n^{\text{th}}$  electromagnetic force harmonics amplitude;  $n$  – harmonics order;  $\varphi_{F_{elm.n}}$  –  $n^{\text{th}}$  electromagnetic force harmonics phase.

The (29) system equation could be rewritten only respectively to the oscillation coordinates  $h_1(t)$  and  $h_2(t)$  Due to the linearity of the mechanical system differential equation system could be replaced with one using Laplace transformation:

$$\begin{cases} m_1 p^2 H_1(p) + (R_1 + R_2)pH_1(p) - R_2 pH_2(p) + \\ + (C_1 + C_2)H_1(p) - C_2 H_2(p) = 0, \\ m_2 p^2 H_2(p) - R_2 pH_1(p) + R_2 pH_2(p) - \\ - C_2 H_1(p) + C_2 H_2(p) = F_{excite}(p). \end{cases} \quad (31)$$

After analysis of the system such transfer functions could be extracted:

$$W_{H1,H2}(p) = \frac{H_1(p)}{H_2(p)} = \frac{(R_2 p + C_2)}{m_1 p^2 + (R_1 + R_2)p + (C_1 + C_2)}, \quad (32)$$

$$W_{H1}(p) = \frac{H_1(p)}{F_{excite}(p)} = \frac{b'_1 p + b'_0}{a_4 p^4 + a_3 p^3 + a_2 p^2 + a_1 p + a_0}, \quad (33)$$

$$W_{H2}(p) = \frac{H_2(p)}{F_{excite}(p)} = \frac{b_2 p^2 + b_1 p + b_0}{a_4 p^4 + a_3 p^3 + a_2 p^2 + a_1 p + a_0}, \quad (34)$$

$$W_{V1}(p) = pW_{H1}(p), \quad W_{A1}(p) = p^2 W_{H1}(p), \quad (35)$$

here the coefficients are:  $a_0=C_1 \cdot C_2$ ,  $a_1=C_1 \cdot R_2 + R_1 \cdot C_2$ ,  $a_2=C_1 \cdot m_2 + C_2 \cdot (m_1 + m_2) + R_1 \cdot R_2$ ,  $a_3=R_1 \cdot m_2 + R_2 \cdot (m_1 + m_2)$ ,  $a_4=m_1 \cdot m_2$ ,  $b'_0=C_2$ ,  $b'_1=R_2$ ,  $b_0=C_1 + C_2$ ,  $b_1=R_1 + R_2$ ,  $b_2=m_1$ .

The other transfer functions can also be extracted and analyzed in search of amplitude and phase response of oscillation amplitude of oscillating mechatronic device.

### Conclusions

The conclusions of this mathematical investigation of the mathematical model of linear oscillating mechatronic devices are:

- The mathematical model of oscillating mechatronic device could be split in three subsystems to analyze electrical, control and mechanical behavior of mechatronic device;

- The presented linearization of nonlinear motor winding inductances  $L(t)$  and their derivatives  $dL(t)/dt$  allows usage of Laplace transformation for electrical subsystem behavior analysis of mechatronic device;

- The control is based on using total current feedback with harmonic analyzer, which extracts values of the amplitudes and phases of the first five odd harmonics and as well as define the microcontroller based control algorithm of the system;

- The mechanical subsystem is being assumed linear two mass system and the assumption allows to analyze transfer functions of mechanical subsystem, and simplifies modeling of the mechatronic system;

- The linearization of thyristor nonlinearity is a further research task.

## References

1. **Rinkevičienė R., Petrovas A.** Dynamic Models of Controlled Linear Induction Drives // *Electronics and Electrical Engineering*. – Kaunas: Technologija, 2005. – No. 5(61). – P. 23–27.
2. **Wang J., Howe D., Lin Z.** Design Optimization of Short-Stroke Single-Phase Tubular Permanent-Magnet Motor for Refrigeration // *Applications*, IEEE Transactions on Industrial Electronics, 2010. – Vol. 57. – No. 1. – P. 327–334.
3. **Brazaitis A., Guseinoviene E., Jankūnas V.** Control of Oscillation Amplitude of Oscillating Motors // *Electronics and Electrical Engineering*. – Kaunas: Technologija, 2010. – No. 3(99). – P. 77–82.
4. **Jankūnas V., Eidukas D., Guseinoviene E., Cirtautas V.** Investigation of Supply Possibilities of Mechatronic Actuator // *Electronics and Electrical Engineering*. – Kaunas: Technologija, 2009. – No. 5(93). – P. 25–28.
5. **Geleževičius V. A., Grigaitis A.** Research of Adaptive Force Control Loop of Electropneumatic Acting System // *Electronics and Electrical Engineering*. – Kaunas: Technologija, 2007. – No. 7(79). – P. 7–10.
6. **Kudarauskas S., Senulis A., Simanygienė L.** Oscillation centre control of the oscillating motor-compressor // *Electronics and Electrical Engineering*. – Kaunas: Technologija, 2004. – No. 7(56). – P. 66–69.
7. **Jankūnas V., Guseinoviene E., Urmonienė L.** Adequacy of Mathematical and Physical Model of Oscillating Mechatronic Device // *Electronics and Electrical Engineering*. – Kaunas: Technologija, 2008. – No. 7(87). – P. 69–72.
8. **Kudarauskas S.** Introduction to Oscillating Electrical Machines. – 2004. – P. 183.
9. **Heo K. B., Lee H. K., Lee C. W., Hwang M. G., Yoo J. Y., Jeon Y. H.** Control of a linear compressor // *Proc. of Intern. Conference on Compressors and their Systems*. – UK, London, 2003. – P. 493–500.
10. **Gu F., Shao Y., Hu N., Naid A., Ball A.D.** Electrical motor current signal analysis using a modified bispectrum for fault diagnosis of downstream mechanical equipment // *Mechanical Systems and Signal Processing*, 2011. – No. 25. – P. 360–372.
11. **Senulis A., Guseinoviene E., Jankūnas V., Urmonienė L., Andziulis A., Didžiokas R.** Experimental Investigation of Oscillation Center Displacement of Oscillating Pulsating Current Motor and Springless Compressor Drive // *Electronics and Electrical Engineering*. – Kaunas: Technologija, 2007. – No. 7(79). – P. 63–66.
12. **Brazaitis A., Guseinoviene E.** Computer Aided Design on Oscillating Drives // *Electronics and Electrical Engineering*. – Kaunas: Technologija, 2006. – No. 6(70). – P. 19–22.
13. **Senulis A., Guseinoviene E., Urmonienė L.** Control Possibilities of Oscillating Electrical Motor Using FFT Analysis Data // *JVE Journal of Vibroengineering*. Kaunas: Vibromechanika, 2010. – No. 1(12). – P. 82–88.

Received 2010 12 12

**A. Senulis, D. Eidukas, E. Guseinoviene. Generalized Mathematical Model of Controlled Linear Oscillating Mechatronic Device // Electronics and Electrical Engineering. – Kaunas: Technologija, 2011. – No. 2(108). – P. 55–60.**

This paper presents the general mathematical model of double-sided springless linear oscillating mechatronic device – oscillating motor-compressor which is supplied by thyristor voltage converter. The model presents possibilities to evaluate losses of the windings and losses in the magnetic circuit, nonlinear inductances, mutual inductances, special current feedback using harmonic analysis for the control, oscillations not only of the moving part, but also the “stator” oscillations. Also using this model such parameters can be calculated – oscillation centre drift, oscillating coordinates and velocities of mover and stator, all currents and voltages, electromagnetic force, harmonics of each time-dependent parameter. Ill. 7, bibl. 13 (in English; abstracts in English and Lithuanian).

**A. Senulis, D. Eidukas, E. Guseinoviene. Apibendrintasis valdomo tiesiaieigio švytuojamojo mechatroninio įtaiso matematinis modelis // Elektronika ir elektrotechnika. – Kaunas: Technologija, 2011. – Nr. 2(108). – P. 55–60.**

Straipsnyje aptariamas apibendrintasis dvipusio bespyruoklio švytuojamojo tiesiaieigio mechatroninio įtaiso – švytuojamojo kompresorinio variklio, maitinamo iš tiristorinio įtampos keitiklio, matematinis modelis. Šis modelis leidžia įvertinti nuostolius apvijose ir magnetinėje grandinėje, netiesinius induktyvumus, abipusį induktyvumą, naudojamą specialų srovės grįžtamąjį ryšį, kurio veikimo principas yra pagrįstas harmonine analize, o rezultatai naudojami valdymui. Šiame modelyje taip pat įvertinami ne tik judžiosios dalies, bet ir „statoriaus“ švytavimai. Naudojant tokį modelį galima apskaičiuoti šiuos parametrus: švytavimų centro poslinkį, švytavimų koordinatas, tiek judžiosios dalies, tiek „statoriaus“ greičius ir pagreičius, elektros grandinės srovės ir įtampas, elektromagnetinę jėgą, taip pat kiekvieno parametro harmonikas. Il. 7, bibl. 13 (anglų kalba; santraukos anglų ir lietuvių k.).