

## Investigation of the characteristics of the low frequency broadband contact transducers

A. Vladiškauskas, R. Raišutis, R. Šlitteris, G. Seniūnas, A. Jankauskas

*Prof. K. Baršauskas Ultrasound Institute,  
Kaunas University of Technology,  
Studentu 50, LT-51368 Kaunas, Lithuania*

### Abstract

In this paper experimental investigation of the characteristics of low frequency ultrasonic broadband contact type transducers is presented. The low frequency transducers are widely used for non-destructive testing and material characterisation, ultrasonic testing and in acoustic emission applications. One of the most important requirements to the low frequency transducers is that their characteristics during long-term contact scanning should not change. In order to measure the beam pattern of the low frequency transducers the special experimental set-up was created. The experimental set-up enables to carry out the measurements of the beam pattern of the contact type transducers which is impossible to perform by other (air-coupled, immersion) methods. The characteristics of the beam pattern of investigated different diameter transducers are presented. In the case of using contact type transducers possessing diameter of the contact surface 0.1 mm, the angle of the beam pattern divergence is about  $116^\circ$ . It shows possibility to excite the shear and the Lamb waves in the layered structures. It was determined experimentally, that the most noticeable differences between the beam patterns of the different diameter transducers are at small angles.

**Keywords:** contact type transducer, wide band ultrasonic transducer, transducer beam patterns, scanning, low frequency

### Introduction

In recent years the low frequency ultrasonic methods are widely applied for investigation of composites materials and their structures, non-destructive testing of tubes, concrete and wood, the measurement of distance and in acoustic emission. Therefore, the field of the ultrasonic investigations can be divided into three groups:

- air-coupled methods;
- immersion methods;
- contact methods.

When the transmitter and the receiver are used separately, the methods can be mixed. For example, one transducer acts as the transmitter in direct contact with the test sample and the receiver could be placed over the test sample in air or in water.

The main advantage of the air-coupled methods compared to the immersion and the contact methods is that it avoids the disadvantages of immersion in water or use of the coupling gel and the time-consuming cleaning after the inspection. Most of the air-coupled methods are based on through-transmission and pitch-catch configurations of transducers [1-5]. They allow getting the best advantage of results in comparison with the pulse-echo method. In the case of air-coupled investigations the difference in a signal amplitude between the transmitter and the receiver can be from -120 dB down to -140 dB due to high difference in the acoustic impedances between the piezoelectric material and air. To overcome high losses of ultrasonic waves at the interface between the transmitter and air, the special construction of the high sensitivity transducers is used [4]. The frequencies in the range of 50-500 kHz are available for examinations of many objects.

The immersion methods are very attractive because the transduction losses are substantially lower. They allow to use higher frequencies in investigations and to get a better resolution. Two ultrasonic through-transmission techniques

were used for investigation of composites: immersion and air-coupled techniques [5]. The immersion systems were used for frequencies from 1 MHz up to 10 MHz and the air-coupled systems were used from 120 kHz up to 400 kHz. The results obtained using both through-transmission techniques shows that the best resolution and sensitivity was obtained by the immersion technique.

The useful way to get more information is to use the environment with the acoustic impedance close to the acoustic impedance of the investigated object as much as possible. It was achieved by fixing one transducer on the edge of the object under investigation (plate) and the receiving transducer was scanned over the plate [6]. It allowed to get the mode transformation from the  $S_0$  mode to the  $A_0$  mode on the welded seams effectively. The scanning of the receiver was performed in water over the surface of the steel plate having thickness of 8 mm.

In another method [7] the contact type transmitting transducer was permanently fixed by epoxy glue on the surface of one side of the aluminium plate. The receiver was placed at the distance of 10 mm over the opposite surface of the plate and scanned along two perpendicular directions.

The immersion methods are very attractive for ultrasonic scanning systems due to low losses. However, water is not compatible with some industrial processes and, for example, may cause permanent damage for many materials used in the aerospace industry. Therefore, the most promising methods for investigation of such materials are contact type methods.

The low frequency contact transducers are widely used for a non-destructive testing and material characterisation, ultrasonic testing of the aerospace materials and in acoustic emission application [8-12]. The ultrasonic testing methods are well developed and presented by a wide variety of tools and instrumentations. However, there are some restrictions

of application of low frequency broadband contact type transducers used for the scanning systems of the multi-layered composite materials and metallic products. During long-term scanning the characteristics of the low frequency contact transducers should not change. The weight of a transducer should be as small as possible because the small weight will not load an assembly of the mechanical scanner. The lateral dimensions also must be small enough in order to achieve a high spatial resolution, to increase the scanning area and separate the waves from the scanning object.

The first experimental investigation of the application of the low frequency broadband contact scanning transducers showed good results for GFRP plate having thickness of 6 mm and for CFRP plate having thickness of 8.4 mm [13]. In this paper further investigation continues the research of the properties of contact broadband transducer in the time, frequency and space domains.

### Investigation of the wavelength and the beam pattern of transducer

The possibilities of application of the low frequency transducers depend on the sensitivity, dimensions, bandwidth of the transducer, transmission angle and on the type of contact between the surface of the transducer and the object under investigation. The frequency response of the reference contact type transducer is presented in Fig. 1 [13]. The frequency band over -6 dB is from 50 kHz up to 350 kHz, which allows to use this transducer for investigation of many multi-layered structures made of composites. The thickness of the protector layer (made of glass fibre material) should not be more than  $\lambda/2$ , where  $\lambda$  is wavelength.

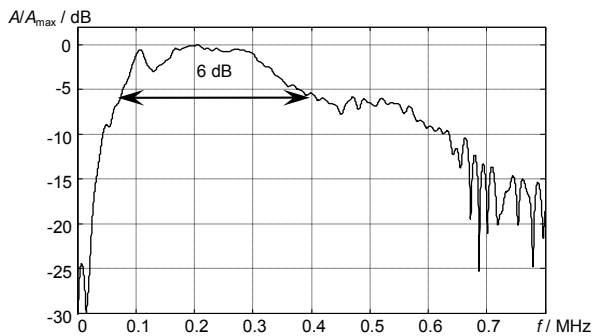

Fig. 1. The frequency response of the reference transducer

The dependence of the wavelength on a frequency in the glass fibre plastics is shown in Fig. 2. The measured ultrasound velocity in the glass fibre was 2800 m/s. From here the wavelength for 50 kHz frequency signal was 56 mm and for 350 kHz was 8 mm. The diameter of the planar protector of the low frequency broadband transducer [14, Fig. 1] was 2 mm and the diameter of the replaceable protector was 3 mm with the plane part on the top of the protector – 0.1 mm.

Investigation of the layered structure needs the transducers which can excite wide spectrum and multi-

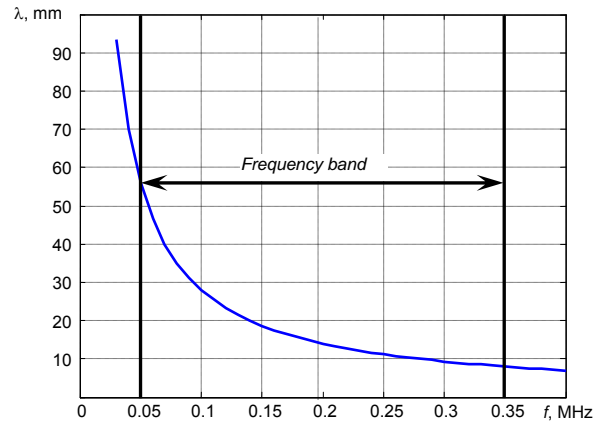

Fig. 2. Dependence of the wavelength on the frequency

mode waves. Besides, in this case, a wide beam pattern of multi-mode waves is desired, as it is achieved for acoustic emission transducers [10]. At low frequencies the small diameter of the transducer enables to get enough wide beam pattern. For measurement of the transducer beam patterns the special experimental set-up was developed (Fig. 3 a, b). It consists of the plexiglass body 1 which was

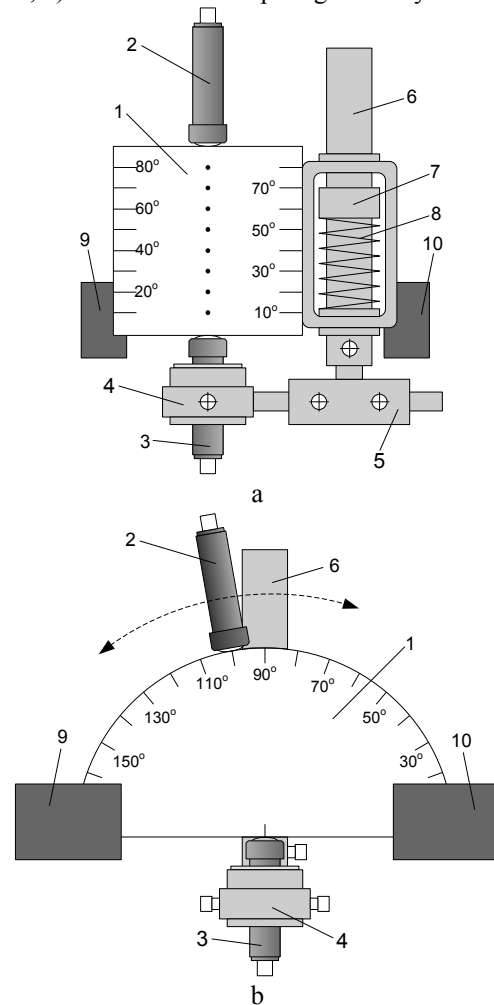

Fig. 3. The experimental set-up ( a – side view, b – front view): 1 – plexiglass body, 2 – receiver, 3 – transmitter, 4 – holder, 5 – adjuster support, 6 – slipper, 7 – drive bushing, 8 – spring, 9, 10 – holders

a semi - cylinder with a diameter of 100 mm and a thickness of 50 mm. The cylindrical surface was marked at each 10<sup>th</sup> degree for set-up the receiver 2, which was the broadband low frequency contact transducer (the diameter of the contact area was 0.1 mm). The transmitter 3 was placed in the center under the experimental set-up in the holder 4 which was connected with the adjuster support 5. The slipper 6 moved in the drive bushing 7 and pressed the transducer to the surface of the plexiglass body. The necessary force for pressing is provided by a screw spring 8. This spring was necessary in order to achieve the uniform force to press the transmitter 3 to the surface of the plexiglass body from below. This set-up was fastened in the two holders 9 and 10.

In the measurement of the beam pattern the transmitter 3 was fastened in the holder 4, which was located in the middle of the plane surface of plexiglass body (Fig. 3 a, b). The receiver was mounted on the cylindrical surface and scanned counter clockwise. The measurements of the received signal amplitude at each 10<sup>th</sup> degrees were carried out.

The results of measurement in the time domain representing signals registered at angle of 90° are shown in Fig. 4 and 5. In Fig. 4 both low frequency broadband transducers were used with point-type contact protectors (0.1 mm) and the glycerine as a contact liquid between transducers and plexiglass body was used. The transmitter was excited by a single pulse possessing duration of which was 3.33 μs and the amplitude 200 V. The amplification of the receiving circuit was 27 dB. Due to finite dimensions of the used plexiglass body there exists not only the direct signal, but many reflections from the edges of the sample also.

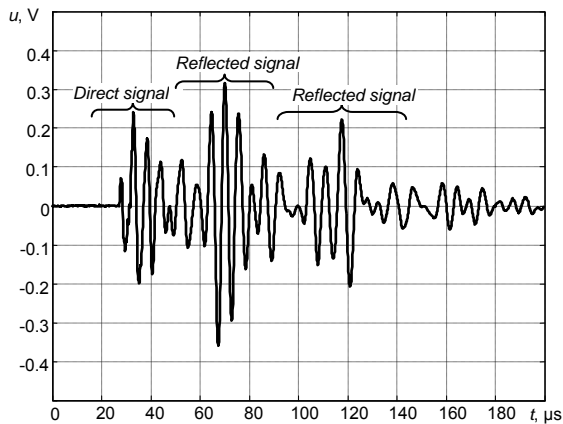

Fig.4. The ultrasonic signal measured at angle of 90°: transmitter – 0.1 mm, receiver – 0.1 mm

The beam pattern of the contact type low frequency broadband transducer (the diameter of the contact area was 0.1 mm) is shown in Fig. 6. The angle of the beam divergence is about 116°. It shows the possibility to excite the shear and the Lamb waves in the layered structure.

The beam pattern of the transducers possessing different diameters of the contact surfaces is shown in Fig. 7. The diameter of the contact area of the transmitter was 5.0 mm, the diameter of the contact area of the receiver protector was 0.1 mm. The most noticeable

difference between the both beam patterns is at small angles.

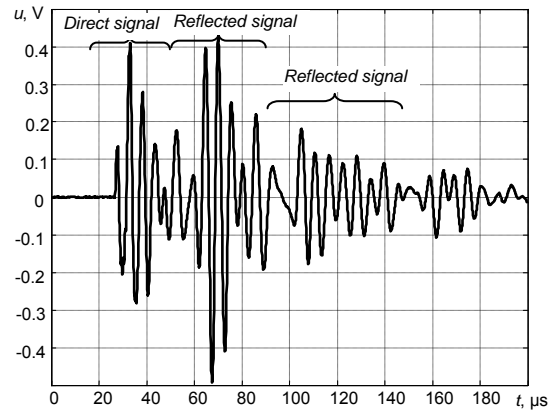

Fig.5. The ultrasonic signal measured at angle of 90°: transmitter – 5.0 mm, receiver – 0.1 mm

It was observed the small amplitude deviations at angles between 80° and 110° in the case when the transmitter having the diameter of the contact surface 5 mm was used. It shows that the ultrasonic beam is more concentrated about the axis of transmitter.

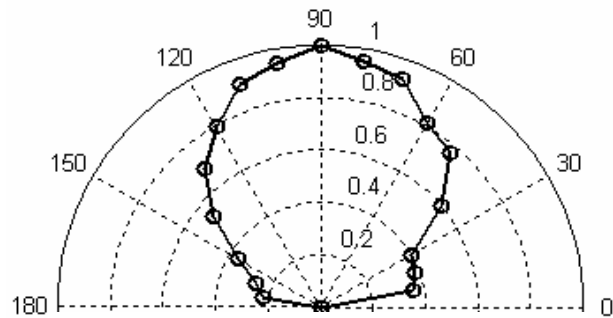

Fig.6. The beam pattern of the transducers: transmitter – 0.1 mm, receiver – 0.1 mm

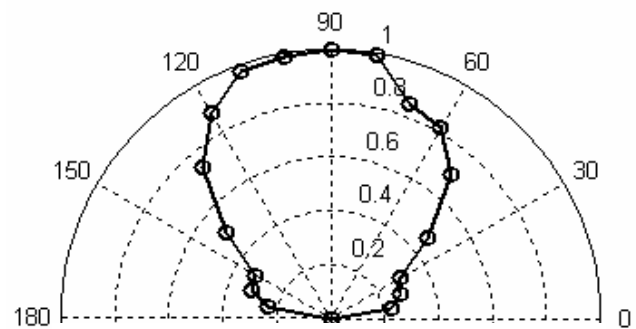

Fig.7. The beam pattern of the transducers: transmitter – 5.0 mm, receiver – 0.1 mm.

The beam patterns of the contact type low frequency broadband transducers shows the normalized amplitudes of the ultrasonic signals. Therefore, the beam pattern of the transducer doesn't show the real amplitudes of the ultrasonic signals, obtained in the cases when various diameter transducers were used. The beam pattern in the Cartesian coordinate system is presented in Fig. 8.

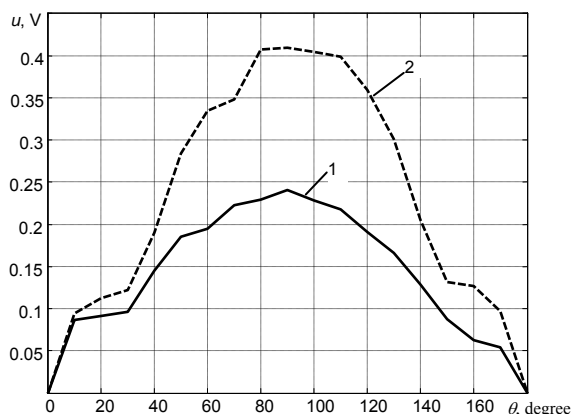

Fig.8. The beam pattern in the Cartesian coordinate system: 1 – transmitter 0.1 mm, receiver 0.1 mm; 2 – transmitter 5.0 mm, receiver 0.1 mm

The solid curve 1 corresponds to the case when both the transmitting and the receiving transducers are point type (0.1 mm) and the dashed curve 2 corresponds to the case when the diameter of the transmitter was 5.0 mm and the diameter of receiver – 0.1 mm. The amplitude of the received ultrasonic signal has been increased by 4.4 dB in the case the transmitter possessing diameter of 5.0 mm was used. It means that using two transducers having diameter of 5.0 mm, the amplitude of the ultrasonic signal could be higher by 8.8 dB. The noticeable difference of amplitude values was obtained from 50° up to 130°.

## Conclusions

The special experimental set-up for investigation of the beam patterns of low frequency wideband contact type transducers was developed. Two types of ultrasonic transducers possessing the frequency band from 50 kHz up to 350 kHz (at -6 dB) were experimentally investigated.

The experimental investigation of beam patterns showed that in the case of using transducers of the same size of the contact surfaces (protectors), the beam pattern is about 116° and it shows the possibility to excite the shear and Lamb waves in the layered structures.

It was experimentally determined that the most noticeable differences between the beam patterns of the transducers possessing different diameters of the contact surfaces are at the small angles.

## References

1. **Kažys R., Demčenko A., Mažeika L., Šlīteris R.** Air-coupled ultrasonic non-destructive testing of aerospace components. *Insight*. Vol. 49. o. 4. P. 1-5.

2. **Demčenko A., Žukauskas E., Mažeika L.** Air-coupled ultrasonic investigation of multi-layered composite materials. *Ultrasonics*. 2006. Vol. 44. Supp. 1. P. e819-e822.
3. **Stoessel R., Krohn N., Pfeleiderer K., Busse G.** Air-coupled ultrasound inspection of various materials. *Ultrasonics*. 2002. Vol. 40. P. 159-163.
4. **Raišutis R., Kažys R., Žukauskas E., Mažeika L., Vladišauskas A.** Application of ultrasonic guided n for non-destructive testing of detective CFRP rods with multiple delaminations. *NDT&E international*. 2010. No.43. P.614-424.
5. **Borum K. K.** Evaluation of the quality of this fibre composites using immersion and air-coupled ultrasonic techniques. *ECNDT*. 2006. We.1.64. P.1-8.
6. **Kažys R., Mažeika L., Barauskas R., Raišutis R., Cicėnas V., Demčenko A.** The analysis of interaction of Lamb waves with defects in loaded steel plates. *Ultrasonics*. 2006. Vol. 44. P. ell 127-ell 130.
7. **Mažeika L., Raišutis R., Maciulevičius A., Žukauskas E., Kažys R., Seniūnas G., Vladišauskas A.** Comparison of several techniques of ultrasonic Lamb waves velocities measurements. *Ultragarsas (Ultrasound)*. 2009. Vol. 64. No. 1. P. 11-17.
8. **Allin J. M., Cowley P.** Design and construction of a low frequency wide band non-resonant transducer. *Ultrasonics*. 2003. Vol. 41. P.147-155.
9. **Nesvijski E. G.** Dry point contact transducers: Design for New Applications. *NDT. Et 2003*. Vol. 9. No.09.
10. **Shevaldykin V. G., Samokrutov A. A., Kozlov V. N.** Ultrasonic low-frequency short-pulse transducers with dry point contact. Development and application. *International symposium NDT-CE 2003*. P. 1-3.
11. **Greenspan M.** The NBS conical transducer. *Analysis. J. Acoust. Soc. Am.* 1987. Vol. 81. No.1. P. 173-182.
12. **Proctor T. M.** An improved piezoelectric acoustic emission transducer. *J. Acoust. Soc. Am.* 1982. Vol. 71. No. 5. P. 1163-1168.
13. **Vladišauskas A., Šlīteris R., Raišutis R., Seniūnas G., Žukauskas E., Mažeika L.** Application of ultrasonic transducers for investigation of composite materials. *Ultragarsas (Ultrasound)*. 2009. Vol. 64. No. 4. P. 36-43.
14. **Vladišauskas A., Šlīteris R., Raišutis R., Seniūnas G.** Contact ultrasonic transducers for mechanical scanning systems. *Ultragarsas (Ultrasound)*. 2010. Vol. 65. No. 2. P. 30-35.

A. Vladišauskas, R. Raišutis, R. Šlīteris, G. Seniūnas, A. Jankauskas

## Plačiajuosčių ultragarsinių žemojo dažnio keitiklių charakteristikų tyrimas

### Reziumė

Atlikti eksperimentiniai žemojo dažnio plačiajuosčių kontaktinių ultragarsinių pjezokeitiklių tyrimai. Gautasios pjezokeitiklių signalų dažninės charakteristikos parodė, kad šių keitiklių dažnio juostos -6 dB lygyje yra nuo 50 kHz iki 400 Hz. Šių dažnių ultragarso bangų ilgis stiklo pluošto audiniuose būna nuo 55 mm iki 8 m. Ultragarsinių pjezokeitiklių kryptingumo charakteristikų matavimai atlikti taikant tam tikslui iš organinio stiklo pagamintą kryptingumo charakteristikų matavimo įrenginį. Matavimo rezultatai parodė, kad dviejų skirtingų aktyvaus ploto 0,1 mm ir 5 mm pjezosiųstuvų kryptingumo charakteristikos skiriasi nedaug, tačiau 5 mm pjezosiųstuvo ultragarso signalo amplitudė beveik du kartus didesnė.

Pateikta spaudai 2010 09 29