

Position Control of an Object Coupled with Motor via Elastic Joint

V. A. Geleževičius

*Department of Control Technology, Kaunas University of Technology,
 Studentų str. 48, LT-51367 Kaunas, Lithuania, phone: +370 37 451610, e-mail: vilnius.gelezevicius@ktu.lt*

Introduction

Traditionally design of drives for position control of objects are to be transported from one defined position to another is based on hierarchical multi-loop structure, consisting of process state coordinates – motor torque, speed and position – control subsystems, integrated into united positioning system. The individual state coordinate controllers adjusted independently under the quantitative or symmetrical optimum conditions are used in this instance. Setting parameters of state coordinate controllers are strictly predefined by control object input data; correspondingly the system could be properly adjusted only having exact information about the control object.

Due to elasticity of mechanical coupling between motor of the drive and object to be positioned, definition of parameters necessary for the main (position) controller setting, conditioned by stiffness and dissipative function of coupling and moment of inertia of moving part, becomes problematic. This circumstance leads to more sophisticated control methods searching and application. The possibilities of acting load observer application [1], and predictive control [2] methods implementation are demonstrated in the following articles.

The reference model based signal adaptive control method enable to compensate an influence of certain mismatch between estimated and real parameters of controlled object consisting of elastic coupling and the transported object itself is presented and investigated in this paper. The modelling results confirming proposed control method are given and discussed.

Control object of position control system with elastic coupling discussion

The electromagnetic torque developed by motor of electric drive can be considered as a control action applied to the control object of whatever positioning system. Taking into account that inner control contour of hierarchical position control system plays the role of actuator motor torque regulation and is designed under the quantitative optimum condition the control object of the system can be described by following equations:

$$\begin{cases} \Omega_M = \frac{1}{J_M} \int (M_M - M_{EC}) dt; \\ \Delta\theta_C = \int (\Omega_M - \Omega_{CO}) dt; \\ M_{EC} = F(c, d, \xi); \\ \Omega_{CO} = \frac{1}{J_{CO}} \int (M_{EC} - M_L) dt; \\ \theta_{CO} = \int \Omega_{CO} dt; \end{cases} \quad (1)$$

where M_M – electromagnetic torque developed by the motor; M_{EC} – torque transmitted to controlled object via elastic joint; M_L – torque of a charging load; J_M – moment of inertia of the motor; J_{CO} – moment of inertia of controlled object; Ω_M and Ω_{CO} – the angular velocities of motor shaft and control object correspondingly; $\Delta\theta_C$ – angular deformation of an elastic shaft; $F(c, d)$ – transfer function of an elastic joint with parameters c – stiffness of the joint, d – dissipative function; θ_{CO} – current position of control object.

On the base of given equations the structural diagram of the control object is built up and presented in Fig. 1.

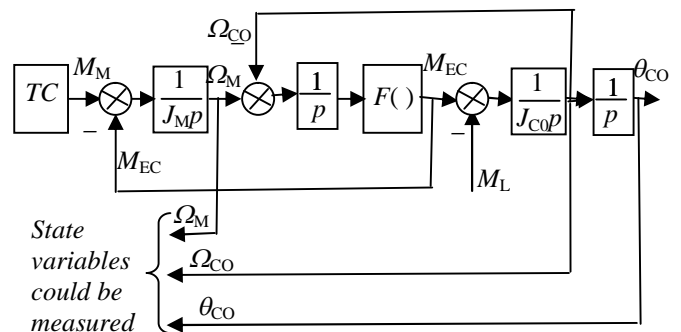

Fig. 1. Structural diagram of a control object of positioning system with elastic coupling

There in this diagram the block TC represents the motor torque control contour, p denotes variable of the

Laplace transformation. Function $F(\cdot) = F(c, d)$ expresses relationship between deformation of the coupling $\Delta\varphi$ and torque M_{EC} applied to the transported control object:

$$M_{EC} = c \cdot \Delta\varphi + d \cdot \frac{d\Delta\varphi}{dt}, \quad (2)$$

Because definition of exact values of parameters c , d is problematic and inertia moment J_{CO} can change during the time, traditional design method of position controller, based on desirable transfer function of position control contour in open state forming can not give acceptable results. Considering this situation the new strategy of position control based on additional transported object speed regulation contour introduction has been proposed and investigated.

Structure of position control system with elastic coupling

The structure of proposed position control system with two speed regulation contours is presented in Fig. 2. System consists of following subsystems: the motor torque control subsystem, the first (motor shaft) speed control subsystem, the second (positioned object) signal adaptive speed control subsystem and the control object position control system.

Supposing the motor torque control subsystem TC being realized under quantitative optimum condition, this subsystem is represented as the first order lag with transfer coefficient k_{TC} and time constant T_{TC} , depending on parameters of electronic power converter and current feedback only.

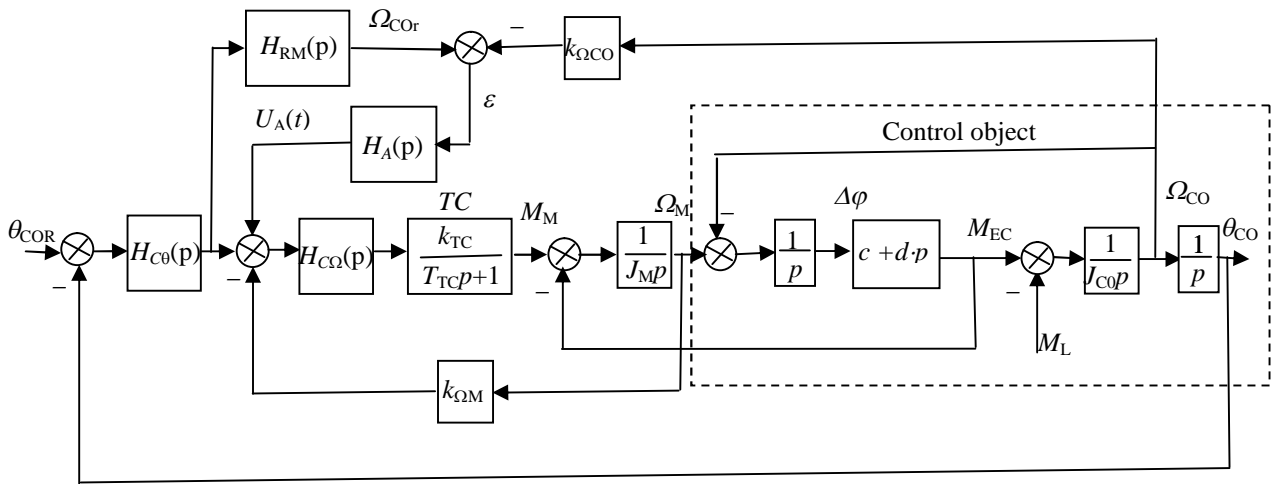

Fig. 2. Structural diagram of position control system with elastic coupling between motor and transported object

Application of two speed control loops is the main feature of proposed control system. The first speed control loop, consisting of conventional speed controller $H_{C\Omega}(p)$, inner motor torque control subsystem TC , mechanical part of the drive motor with transfer function $1/J_M p$ and motor shaft speed feedback k_{Ω_M} , is used for motor shaft speed reaction rapidity on reference signals, generated by position controller $H_{C0}(p)$ and adaptive object velocity controller $H_A(p)$ increasing. In the other hand, due to this motor speed regulation contour an influence of torque M_{EC} on motor shaft speed control quality is diminished. The quantitative optimum condition leads to the velocity controller $H_{C\Omega}(p)$ with proportional control law.

The second speed regulation contour is used for moving object velocity control. This contour includes the first (motor) speed regulation contour, transported object, transported object velocity feedback $k_{\Omega_{CO}}$ and signal adaptive controller $H_A(p)$. The reference signal Ω_{COR} for this control contour is formed with help of reference model $H_{RM}(p)$. Dynamical features of reference model correspond to desirable dynamics of the moving object velocity control contour and match to the transfer function of the system designed under the quantitative optimum condition:

$$H_{RM}(p) = \frac{k_{RM}}{2T_{ES}^2 p^2 + 2T_{ES} p + 1}, \quad (3)$$

where k_{RM} – desirable transfer coefficient of the second speed regulation contour; T_{ES} – equivalent time constant, defining dynamical features of the object velocity control contour.

In order to obtain maximum possible rapidity of measured velocity Ω_{CO} adaptation to the signal Ω_{COR} generated by reference model, it is recommended to design the controller $H_A(p)$ using the Liapunov function method [3]. The Liapunov function of following form

$$V = \gamma_{11} \varepsilon^2(t) + 2\gamma_{12} \varepsilon(t) \cdot \frac{d\varepsilon(t)}{dt} + \gamma_{22} \left(\frac{d\varepsilon(t)}{dt} \right)^2 \quad (4)$$

could be chosen for this purpose:

Maximum rapidity and stability of an adaptive speed regulation contour can be ensured by using relay mode controller $H_A(p)$ forming adaptation signal according to following relationship (5)

$$U_A(t) = -h \cdot \text{sign} \left(\gamma_{12} \varepsilon(t) + \gamma_{11} \frac{d\varepsilon(t)}{dt} \right), \quad (5)$$

where h – amplitude of relay mode adaptation controller output signal.

Supposing that the second adaptive speed control contour is perfectly functioning, the position controller $H_{C0}(p)$ has been developed. This supposition allows considering that transfer function of closed speed control contour is adequate to the reference model transfer function (3). Owing to this the position controller can be designed using conventional series correction principle streaming ensuring the quantitative optimum condition. This leads to proportional position controller use.

System modeling results

The model of the system was developed supposing that initially the position control system has been designed using conventional hierarchical three loop structure consisting of independently adjusted motor torque, speed and transported object position controllers.

The motor torque control loop is presented by approximate resultant transfer function of closed loop adjusted under the optimum rapidity condition $H_{TC}(p) = 10 / (0.002p + 1)$. Parameters of the speed regulation contour: $J_M = 0.33 \text{ kgm}^2$; $k_{\Omega M} = 0,6$; $H_{C\Omega}(p) = 100$. Parameters of the controlled object and elastic joint: $c = 20000$; $d = 20$; moment of inertia of transported object is changing in the interval $J_{CO} = 5 \div 100 \text{ kgm}^2$. The position controller $H_{C0}(p)$ has been adjusted supposing that moment of inertia of object is equal 25 kgm^2 , satisfactory dynamical quality of the positioning process has been reached with $H_{C0}(p) = 5.25$ (Fig.3).

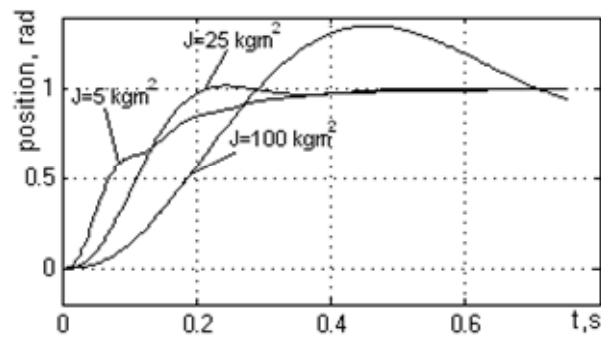

Fig. 3. Influence of control object changing inertia moment on the response of positioning system

In order to avoid influence of changing or uncertain parameters of a control object on dynamical behavior of positioning system with elastic joint the additional speed correction contour is introduced into system. This contour consists of reference model $H_{RM}(p)$, control object speed feedback $k_{\Omega CO}$ and signal adaptive controller $H_A(p)$.

Reference model has been designed in accordance with transfer function (3). The parameters $k_{RM} = 1$ and $T_{ES} = 0.02 \text{ s}$ are chosen on purpose to fit the process as well as possible to the slowest case of positioning ($J_{CO} = 100 \text{ kgm}^2$). The speed feedback gain being equal to $k_{\Omega CO} = 1$, the parameters of signal adaptive controller (5) were selected as follows: $h = 5$; $\gamma_{12} = 10$; $\gamma_{11} = 0.01$.

The modeling results of signal adaptive position control system with elastic joint and changing control object inertia moment are presented in the figures below.

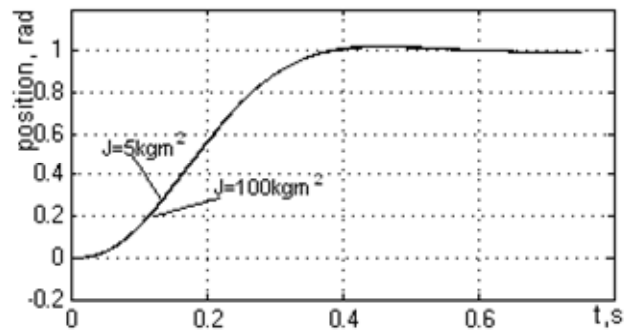

Fig. 4. Responses of control object position to the step mode position reference signal

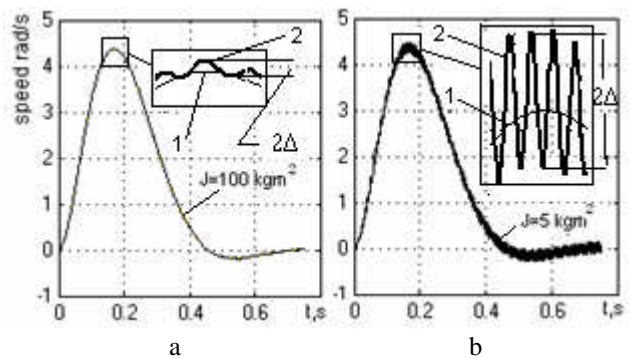

Fig. 5. Responses of control object speed to step the mode position reference signal in the boundary inertia moment cases: 1) speed reference signal; 2) transported object speed

Modeling results presented in Fig. 4 demonstrate theoretical possibility of invariance of positioning quality on elastic joint and transported object parameters ensuring. Control object position responses are practically identical in the large range ($5 \text{ kgm}^2 \div 100 \text{ kgm}^2$) of object inertia change. Nevertheless practical implementation of such control mode with relay mode $H_A(p)$ controller is hardly possible. Owing to relay mode adaptation controller speed correction takes place in the sliding mode with oscillations around the current value of reference signal, Ω_{Cor} . When deviation of parameters of control object enlarges, magnitude of oscillations dramatically increases. This is illustrated by modeling results presented in Fig. 5: speed oscillations are insignificant when object closely correspond to the reference model parameters (Fig. 5a - $J = 100 \text{ kgm}^2$, double magnitude of speed oscillations $2\Delta = 0.007 \text{ rad/s}$) and they strongly increase when declination of object parameters becomes large (Fig. 5b: $J = 5 \text{ kgm}^2$, double magnitude of speed oscillations $2\Delta = 0.2 \text{ rad/s}$).

In order to suppress or diminish speed oscillations the simplified adaptation proportional controller with maximum output values limitation has been applied. Investigation of the system has been carried out with following adaptation controller parameters: $H_A(p) = 25$; and $-10 \leq U_A(t) \leq 10$.

Modeling results of adaptation contour are presented in Fig. 6. Diagrams for the worst case with $J = 5 \text{ kgm}^2$ are given in these diagrams

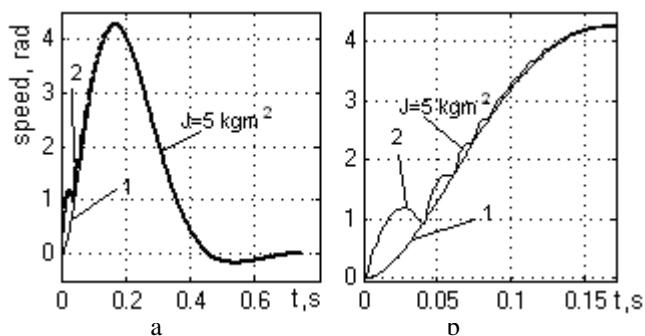

Fig. 6. Control object speed response to step mode positioning reference signal with proportional adaptation contour controller: 1) speed reference signal; 2) transported object speed

As it is seen in the enlarged diagram (Fig 6b), the transported object speed oscillations emerging in the acceleration phase of positioning process are readily suppressed. In the Fig 7 the diagrams illustrating positioning process quality with linear adaptation controller are given.

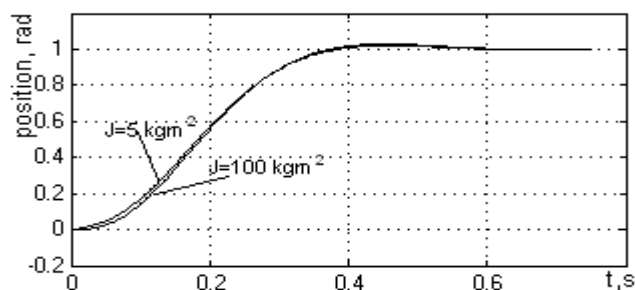

Fig. 7. Responses of control object position to the step mode positioning reference signal

The response curves are practically identical in the all range of object inertia moment change ($J_{CO}=5\div 100 \text{ kgm}^2$).

Conclusions

1. The position control system of an object linked with actuator motor via elastic joint, consisting of two speed regulation loops is presented and investigated in this article.
2. Due to introduced additional signal adaptive transported object speed regulation contour influence of transported object and joint parameters change on dynamical positioning quality was considerably diminished.
3. Proportional signal adaptive controller ensures good compromise between dynamical quality of positioning and transported object speed oscillations in the changing parameters of the object conditions.

References

1. Vittek J., Briš., Makyš P., Štulrajter M., Vavruš V. Control of Flexible Drive with PMSM employing Forced Dynamics. Proceedings of 13th International Power Electronics and Motion Control Conference (EPE-PEMC 2008). Poznan, Poland. 2008. p.p. 2242-2249.
2. Vašak M., Peri N. Protective Predictive Control of Electrical Drives with Elastic Transmission. Proceedings of 13th International Power Electronics and Motion Control Conference (EPE-PEMC 2008). Poznan, Poland. 2008. p.p. 2258-2263.
3. Борцов Ю. А., Поляков Н. Д., Путов В. В. Электромеханические системы с адаптивным и модальным управлением. Энергоатомиздат. Л. 1984. 215 с.

Received 2008 12 12

V. A. Geleževičius. Position Control of an Object Coupled with Motor via Elastic Joint // Electronics and Electrical Engineering. – Kaunas: Technologija, 2009. – No. 2(90). – P. 47–50.

The control method enabling compensating of influence of certain mismatch between estimated and real parameters of elastic coupling and transported object on dynamical quality of positioning is presented and investigated. An additional speed regulation contour ensuring object speed compensation in accordance of signal generated by reference model is applied for this purpose. The two types of speed correction controllers are investigated. The system modeling results are presented. Ill. 7, bibl. 3 (in English; summaries in English, Russian and Lithuanian).

V. A. Gяляжявичус. Система управления положением объекта, соединенного с двигателем при помощи гибкой связи // Электроника и электротехника. – Каунас: Технология, 2009. – No. 2(90). – С. 47–50.

Исследован способ управления, обеспечивающий компенсацию влияния несоответствия реальных параметров гибкой связи и самого объекта на качество позиционирования. Дополнительный контур регулирования скорости, корректирующий скорость объекта согласно сигналу эталонной модели, использован для этой цели. Исследованы два типа корректирующих регуляторов. Представлены результаты моделирования системы. Ил. 7, библи. 3 (на английском языке; рефераты на английском, русском и литовском яз).

V. A. Geleževičius. Tampria jungtimi su varikliu sujungto objekto padėties valdymas // Elektronika ir elektrotechnika. – Kaunas: Technologija, 2009. – No. 2(90). – P. 47–50.

Nagrinėjamas tampria grandimi su pavaros varikliu sujungto objekto padėties valdymo būdas, įgalinantis kompensuoti netikslumą, atsiradusių nustatant tampriosios grandies ar paties objekto parametrus, įtaką pozicionavimo kokybei. Šiam tikslui panaudotas papildomas greičio reguliavimo kontūras, skirtas pozicionuojamo objekto greičiui koreguoti pagal etaloninio modelio suformuotą signalą. Ištirti dviejų tipų greičio koregavimo reguliatoriai. Pateikti sistemos modeliavimo rezultatai. Il. 7, bibl. 3 (anglų kalba, santraukos anglų, rusų ir lietuvių k.).