

Performance Analysis of an Unreliable Queuing System with Buffer Threshold Control and a Reserved Channel

R. Rindzevičius, P. Tervydis

Department of Telecommunications, Kaunas University of Technology

Studentų str. 50-423, LT-51368 Kaunas, Lithuania, e-mail: Ramutis.Rindzevicius@ktu.lt

Introduction

In this article we propose an exact analysis of a queuing system with threshold control and a reserved transmission channel. Our main goal in this paper is to develop an efficient method for computing the steady state probabilities of a queuing system with threshold control, which will allow computation of system performance measures. Two types of the queuing system with a reliable and unreliable main transmission channel are analyzed. Analysis of the systems is based on Markov birth and death processes. Our proposed analytical models are used for analysis of processes in a queuing system which uses main and reserved channels and serves data packets arriving in Poisson flows. We proposed the buffer threshold control method to improve the data packet delay parameter. Much research efforts has been and remains devoted to improving the performance measures of data packet transmission networks [1]. A queuing system with batch Markovian arrival processes and several operation modes, which are controlled by means of threshold strategy, is investigated by Kim C.S. [2]. Asymptotic optimality of a threshold policy is applied for dynamic scheduling of a queuing system with two parallel servers in [4]. A dynamic control policy of threshold queuing and Markov chain analysis is employed in [5] by Larsen R.L.

Most research to date has focused on supporting quality of service (*QoS*) within a single network node, and analysis of such a queuing data network node is currently an active area of research.

Accurate modeling of the offered traffic and its transmission via an unreliable system with reservation and buffer threshold control is the first step in analysis of such system quality of service parameters [3,6]. *QoS* parameters in our models are expressed in the following parameters: data packet losses, channel utilization parameters, probabilities of channel and system failures, mean value of waiting time, average number of data packets in the buffer.

Unfortunately, most queuing problems are not available in analytic form. Therefore, we propose the simulation model of the $G/G/2/(N)K$ system to evaluate the performance parameters of an unreliable system with buffer threshold control and a reserved channel.

Analytical model of an $M/M/2/(N)K$ system with threshold control.

We will investigate a queuing system with finite buffer K capacity and threshold control at the level $N < K$. First we present the analytical model of the Markov birth-death system when the main transmission channel is without failures. Data packet length l_p is exponentially distributed and packets arrive to the system in accordance with a Poisson process. Data packet buffer capacity $K=4$, and threshold control level $N=2$. Main transmission and reserve channel data packet transmission intensities are respectively equal to μ_1, μ_2 , main channel failure rate is γ , mean time between failures is exponentially distributed, main channel repair intensity r , and repair time is exponentially distributed. The structure of such a system is shown in Fig. 1.

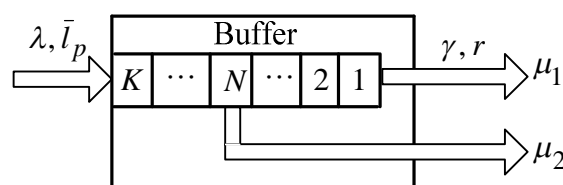

Fig. 1. The structure of queuing system $M/M/2/(N)K$

Data packets are transmitted only via the main transmission channel until the buffer achieves threshold level N . The reserve channel is used in two cases: when the number of packets in the buffer is equal to the threshold N , and when the main channel has failed. When the main channel has failed all arriving packets are served by the reserve channel without considering the number of data packets placed in the buffer. A birth-death Markov model of such a system when the main channel is without failures is shown in Fig. 2.

Each system steady state is described by the vector of three parameters XYZ . Main channel state parameter $X=0$ when the main channel is free, and $X=1$ when the channel is busy. Reserve channel state parameter $Y=0$ when the reserve channel is free, and $Y=1$ when the channel is occupied. System buffer state parameter Z indicates the

number of data packets placed in the buffer and may vary from 0 to full buffer capacity K .

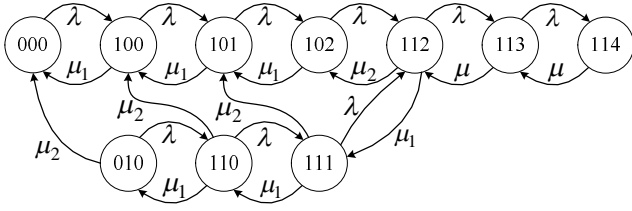

Fig. 2. Continuous time and discrete state Markov birth and death process of queuing system $M/M/2/(N)K$ when the main transmission channel is without failures, in case $N=2, K=4$

Data packet transmission intensity for each channel is given by $\mu_1 = C_1 / \bar{l}_p$; $\mu_2 = C_2 / \bar{l}_p$, where C_1, C_2 is the transmission bit rate of each channel, \bar{l}_p is the mean value of data packet length in bits. Let $\mu_1 + \mu_2 = \mu$.

In this case, using the global balance concept, we can easily write down the following equations:

$$\begin{cases} \lambda P_{000} - \mu_1 P_{100} - \mu_2 P_{010} = 0; \\ (\lambda + \mu_1) P_{100} - \lambda P_{000} - \mu_1 P_{101} - \mu_2 P_{110} = 0; \\ (\lambda + \mu_1) P_{101} - \lambda P_{100} - \mu_1 P_{102} - \mu_2 P_{111} = 0; \\ (\lambda + \mu_1) P_{102} - \lambda P_{101} - \mu_2 P_{112} = 0; \\ (\lambda + \mu) P_{112} - \lambda P_{102} - \lambda P_{111} - \mu P_{113} = 0; \\ (\lambda + \mu) P_{113} - \lambda P_{112} - \mu P_{114} = 0; \\ \mu P_{114} - \lambda P_{113} = 0; \\ (\lambda + \mu_2) P_{010} - \mu_1 P_{110} = 0; \\ (\lambda + \mu) P_{110} - \lambda P_{010} - \mu_1 P_{111} = 0; \\ (\lambda + \mu) P_{111} - \lambda P_{110} - \mu_1 P_{112} = 0; \\ P_{000} + P_{100} + P_{101} + P_{102} + P_{112} + P_{113} + P_{114} + P_{010} + \\ P_{110} + P_{111} = 1. \end{cases} \quad (1)$$

By solving (1) equations we obtain the system state probabilities P_{XYZ} . This can be used to find such queuing system performance measures as:

1) Channel utilization:

$$Y_1 = 1 - P_{000}; \quad (2)$$

$$Y_2 = P_{010} + P_{110} + P_{111} + P_{112} + P_{113} + P_{114}. \quad (3)$$

2) Mean number of data packets in a buffer \bar{N}_q :

$$\bar{N}_q = P_{101} + P_{111} + 2(P_{102} + P_{112}) + 3P_{113} + 4P_{114}. \quad (4)$$

3) Data packet loss probability:

$$P_l = P_{114}. \quad (5)$$

4) The average time spent by data packets in a buffer (delay) in accordance with Little's law:

$$\bar{W} = \frac{\bar{N}_q}{\lambda(1 - P_l)} = \frac{\bar{N}_q}{\lambda(1 - P_{114})}. \quad (6)$$

5) The probability that a data packet arriving to the system must wait:

$$\Pr\{W > 0\} = P_{101} + P_{102} + P_{111} + P_{112} + P_{113} + P_{114}. \quad (7)$$

Continuous time and discrete state Markov process for the system processes when the main transmission channel is subject to failure and repair is shown in Fig. 3. In this case each system steady state is described by the vector of three parameters XYZ . Main channel state parameter $X=0$ when the main channel is free, $X=1$ when the channel is busy, and $X=x$ when the main channel has failed. Reserve channel state parameter $Y=0$ when the reserve channel is free, and $Y=1$ when the channel is occupied. System buffer state parameter Z indicates the number of data packets placed in the buffer and may vary from 0 to full buffer capacity $K=4$.

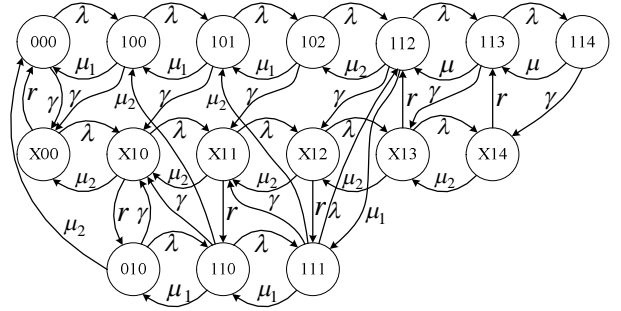

Fig. 3. Continuous time and discrete state Markov birth and death process of queuing system $M/M/2/(N)K$ when the main channel is subject to failure and repair, in case $N=2, K=4$

When the main channel has failed all arriving packets are served by the reserve channel without considering the number of data packets placed in the buffer. Data packet transmission intensity when both channels are operating properly is $\mu = \mu_1 + \mu_2$.

Using the global balance concept, we can easily write down the following equations:

$$\begin{cases} P_{000}(\lambda + \gamma) - \mu_1 P_{100} - \mu_2 P_{010} - r P_{X01} = 0; \\ P_{100}(\lambda + \mu_1 + \gamma) - \lambda P_{000} - \mu_1 P_{101} - \mu_2 P_{110} = 0; \\ P_{101}(\lambda + \mu_1 + \gamma) - \lambda P_{100} - \mu_1 P_{102} - \mu_2 P_{111} = 0; \\ P_{102}(\lambda + \mu_1 + \gamma) - \lambda P_{101} - \mu_2 P_{112} = 0; \\ P_{112}(\lambda + \mu + \gamma) - \lambda P_{102} - \mu P_{113} - \lambda P_{111} - r P_{X13} = 0; \\ P_{113}(\lambda + \mu + \gamma) - \lambda P_{112} - \mu P_{114} - r P_{X14} = 0; \\ P_{114}(\mu + \gamma) - \lambda P_{113} = 0; \\ P_{010}(\lambda + \mu_2 + \gamma) - \mu_1 P_{110} - r P_{X10} = 0; \\ P_{110}(\lambda + \mu + \gamma) - \lambda P_{010} - \mu_1 P_{111} - r P_{X11} = 0; \\ P_{111}(\lambda + \mu + \gamma) - \lambda P_{110} - \mu_1 P_{112} - r P_{X12} = 0; \\ P_{X00}(\lambda + r) - \mu_2 P_{X10} - \gamma P_{000} - \gamma P_{100} = 0; \\ P_{X10}(\lambda + \mu_2 + r) - \lambda P_{X00} - \mu_2 P_{X11} - \gamma(P_{101} + P_{010} + P_{110}) = 0; \\ P_{X11}(\lambda + \mu_2 + r) - \lambda P_{X10} - \mu_2 P_{X12} - \gamma(P_{111} + P_{102}) = 0; \\ P_{X12}(\lambda + \mu_2 + r) - \lambda P_{X11} - \mu_2 P_{X13} - \gamma P_{112} = 0; \\ P_{X13}(\lambda + \mu_2 + r) - \lambda P_{X12} - \mu_2 P_{X14} - \gamma P_{113} = 0; \\ P_{X14}(\mu_2 + r) - \lambda P_{X13} - \gamma P_{114} = 0; \\ P_{000} + P_{100} + P_{101} + P_{102} + P_{112} + P_{113} + P_{114} + P_{X00} + P_{X10} + \\ P_{X11} + P_{X12} + P_{X13} + P_{X14} + P_{010} + P_{110} + P_{111} = 1. \end{cases} \quad (8)$$

Queuing system performance measures are calculated by solving the underlying system of linear equations and some results of these performance measures are obtained:

1) Data packet loss probability in the system:

$$P_l = P_{114} + P_{X14}. \quad (9)$$

2) Channel utilization:

$$Y_1 = P_{100} + P_{101} + P_{102} + P_{112} + P_{113} + P_{114} + P_{110} + P_{111}, \quad (10)$$

$$Y_2 = P_{112} + P_{113} + P_{114} + P_{X10} + P_{X11} + P_{X12} + P_{X13} + P_{X14} + P_{010} + P_{110} + P_{111}. \quad (11)$$

3) Mean value of the number of data packets in the buffer:

$$\bar{N}_q = P_{101} + P_{X11} + P_{111} + 2(P_{102} + P_{112} + P_{X12}) + 3(P_{113} + P_{X13}) + 4(P_{114} + P_{X14}) \quad (12)$$

or according to Little's law

$$\bar{N}_q = \lambda(1 - P_l) \cdot \bar{W}. \quad (13)$$

4) Mean waiting time in the buffer for data packets:

$$\bar{W} = \frac{\bar{N}_q}{\lambda(1 - P_l)} = \frac{\bar{N}_q}{\lambda(1 - P_{114} - P_{X14})}. \quad (14)$$

5) Mean number of data packets in the system:

$$\bar{N}_s = \bar{N}_q + Y_1 + Y_2. \quad (15)$$

6) Main channel fault probability:

$$P_{1f} = P_{X00} + P_{X10} + P_{X11} + P_{X12} + P_{X13} + P_{X14}. \quad (16)$$

7) Mean time spent in the system by each data packet:

$$\bar{T}_s = \bar{W} + \left[\frac{Y_1}{(Y_1 + Y_2)\mu_1} + \frac{Y_2}{(Y_1 + Y_2)\mu_2} \right] \quad (17)$$

or in accordance with Little's law

$$\bar{T}_s = \frac{\bar{N}_s}{\lambda(1 - P_l)}. \quad (18)$$

8) The probability that a data packet arriving in the system must wait:

$$\Pr\{W > 0\} = P_{101} + P_{102} + P_{111} + P_{112} + P_{113} + P_{114} + P_{X11} + P_{X12} + P_{X13} + P_{X14}. \quad (19)$$

The numerical evaluation of a queuing system performance measures as a function of traffic intensity using the analytical model (17, 9, 14, 10, 11, 12) is shown in Fig. 4-7. Calculation results show how \bar{T}_s , \bar{N}_q , Y_1 , Y_2 and P_l values depend on ρ ($\rho = \lambda/\mu$) and how it is related to the μ_1/μ_2 ratio.

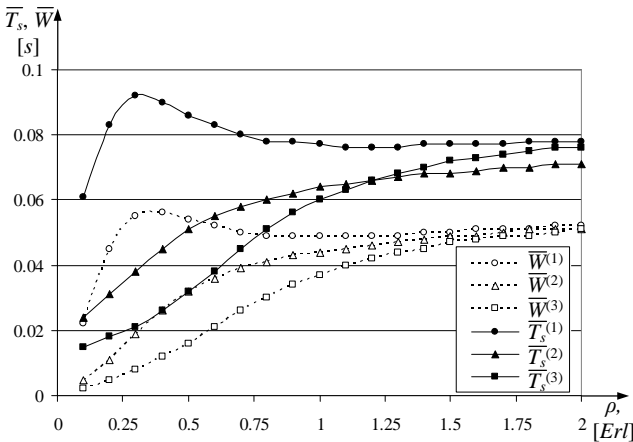

Fig. 4. \bar{T}_s and \bar{W} as a function of ρ , when: $N=2, K=4$,
1) $\mu_1/\mu_2=1/3$, 2) $\mu_1/\mu_2=1$, 3) $\mu_1/\mu_2=3$

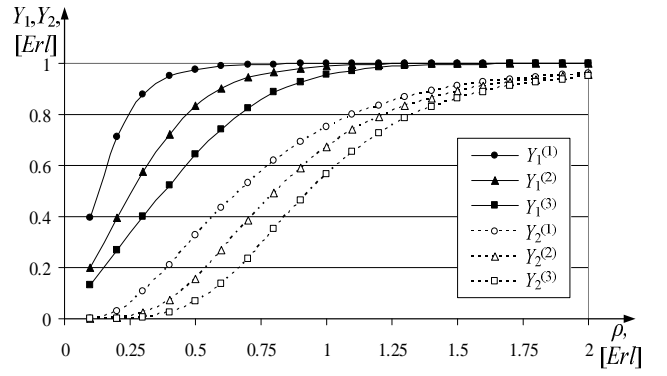

Fig. 5. Y_1 and Y_2 as a function of ρ , when: $N=2, K=4$,
1) $\mu_1/\mu_2=1/3$, 2) $\mu_1/\mu_2=1$, 3) $\mu_1/\mu_2=3$

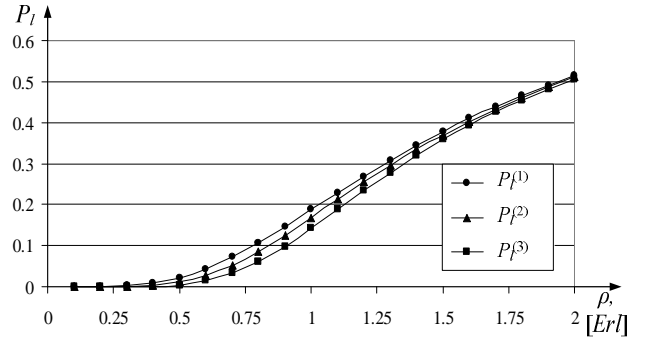

Fig. 6. P_l as a function of ρ , when: $N=2, K=4$, 1) $\mu_1/\mu_2=1/3$,
2) $\mu_1/\mu_2=1$, 3) $\mu_1/\mu_2=3$

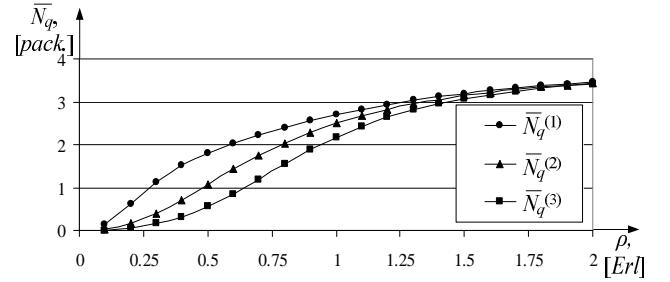

Fig. 7. \bar{N}_q as a function of ρ , when: $N=2, K=4$, 1) $\mu_1/\mu_2=1/3$,
2) $\mu_1/\mu_2=1$, 3) $\mu_1/\mu_2=3$

Simulation model of a $G/G/2/(N)K$ system with buffer threshold control

It is clear from the material above, that the analytical model of $M/M/2/(N)K$ will be very complicated for bigger K and N values. Another problem is that the given model is suitable only if data packet arrival and service processes are Poisson. Therefore, in this chapter we present the simulation model of a $G/G/2/(N)K$ system with buffer's threshold control, which doesn't have these mentioned shortcomings.

The long-term reliability of the system's channels can be described by their availability coefficients [6]:

$$A_j = \frac{r_j}{\gamma_j + r_j}; \quad (20)$$

here j – channel number. Then the 1-st and 2-nd channel states (1 – working state, 0 – failure state) over the i -th time moment can be modeled by

$$p_{j_i} \leftarrow \text{if}(\alpha_{j_i} - A_j < 0, 1, 0), j = 1, 2; \quad (21)$$

here: “ \leftarrow ” – value assignment symbol, $\text{if}(a, b, c)$ – conditional operator (a – condition statement, b – result if $a = \text{TRUE}$, c – result if $a = \text{FALSE}$), α_{1_i} and α_{2_i} are random uniformly distributed values over $(0, 1)$ interval ($\alpha_{1_i} \sim U(0, 1), \alpha_{2_i} \sim U(0, 1)$).

The number of data packets (λ_i), which arrive in the system over the i -th time moment, can be constant or random.

Many mathematical calculation programs have built-in random number generation functions. For example, in MathSoft’s MathCad package the set of n random λ_i values (here $i \in 1, 2, \dots, n$), which are Poisson distributed, can be generated by $\text{rpois}(n, \lambda)$. It is clear, that using the programs it is very easy to model the system with desired λ, μ_1 and μ_2 distributions.

Having the sets $\{\lambda\}, \{\mu_1\}, \{\mu_2\}, \{p_1\}, \{p_2\}$ of random $\lambda_i, \mu_{1i}, \mu_{2i}, p_{1i}$ and p_{2i} values, it is possible to continue the simulation process.

In case of a Bernoulli channel failure process, the $\{\mu_1\}$ and $\{\mu_2\}$ values are recalculated by

$$\mu_{j_i} \leftarrow \mu_{j_i} \cdot p_{j_i}, j = 1, 2. \quad (22)$$

Therefore, if the 1-st or 2-nd channel is in a state of failure then its packet transmission intensity is equal to zero.

The maximum possible number of packets which can be transmitted over the i -th time moment is given by

$$N_{m_i} \leftarrow N_{q_{i-1}} + \lambda_i; \quad (23)$$

here $N_{q_{i-1}}$ – the number of packets in the queue at the beginning of the i -th time moment (or at the end of the $(i-1)$ -th time moment).

Then the number of data packets transmitted over the 1-st channel during the i -th time moment is given by

$$\lambda_{s1_i} \leftarrow \text{if}(N_{m_i} < \mu_{1_i}, N_{m_i}, \mu_{1_i}). \quad (24)$$

The number of data packets transmitted over the 2-nd channel during i -th time moment is given by

$$\lambda_{s2_i} \leftarrow \text{if}(\mu_{1_i} > 0, [\text{if}(N > N_{m_i} - \lambda_{s1_i}, 0, \text{if}(N_{m_i} - \lambda_{s1_i} < \mu_{2_i}, N_{m_i} - \lambda_{s1_i}, \mu_{2_i})]), \text{if}(N_{m_i} < \mu_{2_i}, N_{m_i}, \mu_{2_i})). \quad (25)$$

Therefore, the total number of data packets transmitted over the system during the i -th time moment is

$$\lambda_{s_i} \leftarrow \lambda_{s1_i} + \lambda_{s2_i}. \quad (26)$$

Then the number of data packets in the queue at the end of i -th time moment is

$$N_{q_i} \leftarrow \text{if}(N_{m_i} \leq \lambda_{s1_i}, 0, \text{if}(N_{m_i} - \lambda_{s_i} < K, N_{m_i} - \lambda_{s_i}, K)). \quad (27)$$

Then the number of lost data packets at the end of i -th time moment is given by

$$\lambda_{l_i} \leftarrow \text{if}(N_{m_i} - K > \lambda_{s1_i}, N_{m_i} - K - \lambda_{s1_i}, 0). \quad (28)$$

The system simulation consists of the cycle of n calculations. Therefore, it can be written by

$$X(\{\lambda\}, \{\mu_1\}, \{\mu_2\}, N_{q_0}) :=$$

$$\begin{array}{l} \text{for } i \in 1..n \\ N_{m_i} \leftarrow N_{q_{i-1}} + \lambda_i; \\ \lambda_{s1_i} \leftarrow \text{if}(N_{m_i} < \mu_{1_i}, N_{m_i}, \mu_{1_i}); \\ \lambda_{s2_i} \leftarrow \text{if}(\mu_{1_i} > 0, [\text{if}(N > N_{m_i} - \lambda_{s1_i}, 0, \\ \text{if}(N_{m_i} - \lambda_{s1_i} < \mu_{2_i}, N_{m_i} - \lambda_{s1_i}, \\ \mu_{2_i})], \text{if}(N_{m_i} < \mu_{2_i}, N_{m_i}, \mu_{2_i})); \\ \lambda_{s_i} \leftarrow \lambda_{s1_i} + \lambda_{s2_i}; \\ N_{q_i} \leftarrow \text{if}(N_{m_i} \leq \lambda_{s1_i}, 0, \\ \text{if}(N_{m_i} - \lambda_{s_i} < K, N_{m_i} - \lambda_{s_i}, K)); \\ \lambda_{l_i} \leftarrow \text{if}(N_{m_i} - K > \lambda_{s1_i}, \\ N_{m_i} - K - \lambda_{s1_i}, 0); \\ \text{result: } \{\lambda_{s1}\}, \{\lambda_{s2}\}, \{N_{q_i}\}, \{\lambda_{l_i}\}. \end{array} \quad (29)$$

Having the values of $\{\lambda_{s1}\}, \{\lambda_{s2}\}, \{N_{q_i}\}$ and $\{\lambda_{l_i}\}$ sets, it is possible to calculate the following parameters:

1) Probability of data packet loss in the system:

$$P_l = \frac{\sum_{i=1}^n \lambda_{l_i}}{n \cdot \lambda}; \quad (30)$$

2) Channel utilization:

$$Y_j = \frac{\sum_{i=1}^n \lambda_{sj_i}}{n \cdot \mu_j}; j = 1, 2. \quad (31)$$

3) Mean value of the number of data packets in the buffer ($\overline{N_q}$) can be calculated by (13).

4) Mean waiting time in the buffer for data packets (\overline{W}) can be calculated by (14).

5) Mean number of data packets in the system ($\overline{N_s}$) is given by (15).

6) Mean time spent in the system by each data packet ($\overline{T_s}$) is given by (18).

Parameter evaluation using the simulation model

In this chapter we illustrate how the proposed model could be used for practical applications. For that purpose, let’s take an example of the network connection used for VoIP transmission services (Fig. 8). Here the proposed model of buffer threshold control is implemented in the router, which is in the disposition of calls originating VoIP operator. Two internet service providers (ISP1 and ISP2) for appropriate 1-st and 2-nd channels are used to ensure the better availability and quality parameters of VoIP transmission services. The 2-nd channel is used in case of the 1-st channel’s failure, or if the number of VoIP packets in the buffer is equal to or greater than N . The VoIP transmission quality parameters (such as data packet loss (P), delay (T_s)) and the level of 1-st and 2-nd channel utilization (Y_1 and Y_2) also depend on the selected N value. Therefore, the selection of the optimal N value and the

estimation of VoIP transmission quality parameters are very important.

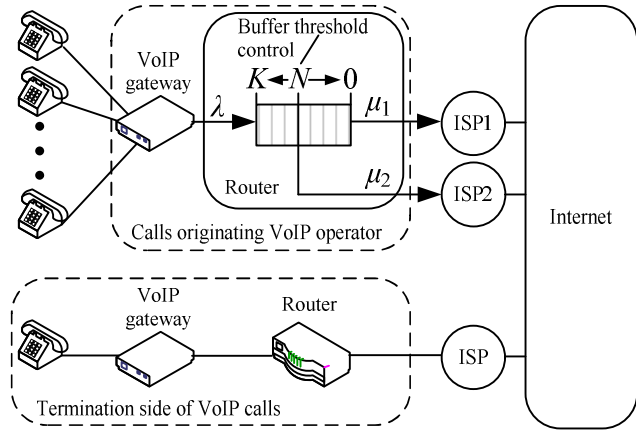

Fig. 8. VoIP transmission system with buffer threshold control mechanism

Due to paper size limitations it is not possible to present the whole complex of calculations that can be made using the given model. We have already presented the methods of VoIP system reliability estimation in [6]. Therefore, to evaluate the buffer threshold control mechanism, we took case when the channels are reliable.

Let's take case when VoIP packet arrival and transmission processes are Poisson. Other initial parameters are given in the Table 1.

Table 1. VoIP transmission system parameters

VoIP packet size	74 B (G.729 codec with 20 ms payload)	
Data transmission rate over ISP1 channel	1)	256Kb/s → $\mu_1^{(1)} = 442.8 \text{ pack./s}$
	2)	512 Kb/s → $\mu_1^{(2)} = 855.6 \text{ pack./s}$
	3)	768 Kb/s → $\mu_1^{(3)} = 1328.4 \text{ pack./s}$
Data transmission rate over ISP2 channel	1)	768 Kb/s → $\mu_2^{(1)} = 1328.4 \text{ pack./s}$
	2)	512 Kb/s → $\mu_2^{(2)} = 855.6 \text{ pack./s}$
	3)	256 Kb/s → $\mu_2^{(3)} = 442.8 \text{ pack./s}$
Buffer size	4 KB → $K = 55 \text{ pack.}$	

In the given case, the channels are reliable. Therefore, packet losses are caused only by buffer overflow (when $\lambda > \mu_1 + \mu_2$). It is shown in Fig. 9.

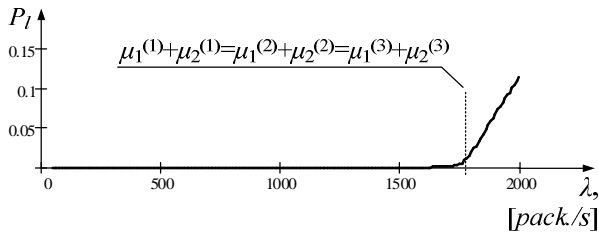

Fig. 9. P_l as a function of λ (other parameters are in the Table 1)

Simulation results, which show how the \bar{N}_q , \bar{T}_s , Y_1 and Y_2 values depend on λ and how it is related to the selected buffer threshold values, are presented in Fig. 10-12.

It is shown in the Fig. 10 that the mean number of VoIP packets in the buffer (\bar{N}_q) is related to the selected buffer threshold (N) values: $\bar{N}_q = N$ when $\mu_1 < \lambda < \mu_1 + \mu_2$. It is obvious that it also affects the \bar{T}_s values (Fig. 11).

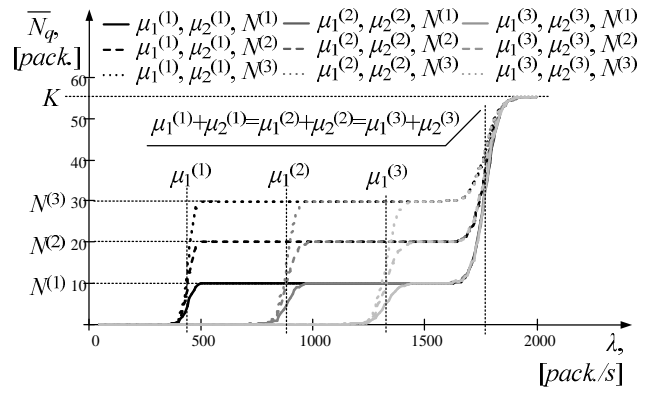

Fig. 10. \bar{N}_q as a function of λ , when: $N^{(1)} = 10 \text{ pack.}$, $N^{(2)} = 20 \text{ pack.}$, $N^{(3)} = 30 \text{ pack.}$ (other parameters are in the Table 1)

It is shown in the Fig. 11 that it is possible to determine the \bar{T}_s values by selecting the appropriate μ_1 , μ_2 and N values.

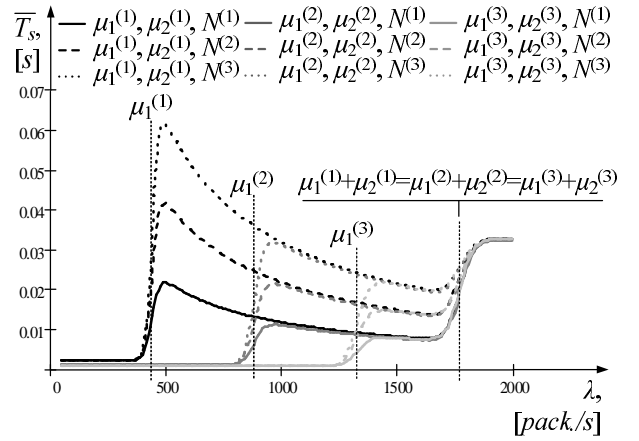

Fig. 11. \bar{T}_s as a function of λ , when: $N^{(1)}=10 \text{ pack.}$, $N^{(2)} = 20 \text{ pack.}$, $N^{(3)} = 30 \text{ pack.}$ (other parameters are in the Table 1)

It may be applied in the practical VoIP systems to ensure the non-critical VoIP packet transmission delay and to optimize the channel bandwidth usage. It is very important if the VoIP operator wants to minimize the reserve channel usage expenses.

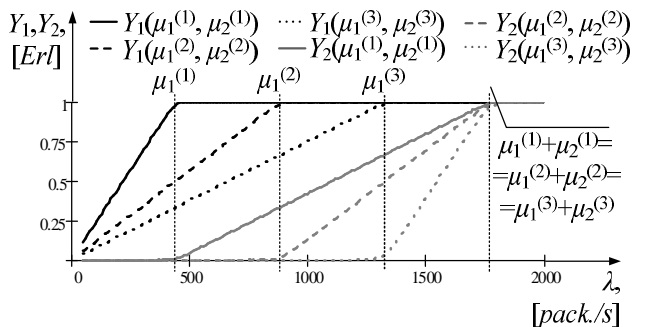

Fig. 12. Y_1 and Y_2 as a function of λ , when: $N^{(1)}=10 \text{ pack.}$, $N^{(2)} = 20 \text{ pack.}$, $N^{(3)} = 30 \text{ pack.}$ (other parameters are in the Table 1)

For example, the simulation results show (Fig. 11-12) that it is necessary to choose 512 Kb/s bandwidth for both channels and $N=10 \text{ pack.}$ to ensure the $\bar{T}_s < 30 \text{ ms}$ and $Y_2 \leq 0.1$ for 20 simultaneous VoIP calls ($\lambda = 1000 \text{ pack./s}$ if 20 ms of voice is placed in a packet).

Conclusions

The system analytical models are accurate only in case of Poisson traffic and exponential data packet transmission time in channel. An exact analytical model becomes complicated when the system has an unreliable main transmission channel and size of buffer is large. More general study of system performance measures may be achieved by means of simulation.

Data packet loss probability can be substantially decreased by increasing system's queue length, when the losses happen due to queue's overflow. It is possible to calculate optimal queue length (K) for a given performance values.

The buffer threshold control mechanism may be applied in the practical real-time data transmission systems to ensure the non-critical packet transmission delay and to optimize the data transmission channel bandwidth usage.

By increasing the number of independent working channels for a network node it is possible to increase its availability and traffic serving possibilities. For maximum efficiency the optimal number of network channels should be selected for required (demanded) system performance values.

References

1. **Rykov V., Efrosinin D.** Optimal Control of Queuing System with Heterogeneous Servers. *Queuing Systems*, vol.46, No3-4, 2004, – P.389–407.
2. **Kim C. S., Konechny A., Dudin A.** Threshold Control by a Single-Server Retrial Queue with Batch Arrivals and Group Services. *Operations Research Letters*, vol.34, issue5, September 2006, P. 548–556.
3. **Rindzevičius R., Adlys G.** Performance Measures of Data Network Node with Buffer Threshold Control // *Electronics and Electrical Engineering*. – Kaunas: Technologija, 2007. – No. 8(80). – P. 29–34.
4. **Bell S. L., Williams R. J.** Dynamic Scheduling of a System with Two Parallel Servers in Heavy Traffic with Resource Polling: Asymptotic Optimality of a Threshold Policy. *Annals of Applied Probability*, vol.11, No.3, 2001, – P.608–649.
5. **Larsen R. L., Agrawala A. K.** Control of a Heterogeneous Two-Server Exponential Queuing System. *IEEE Transactions on Software Engineering*, vol.9, No.4, 1983, P.522–526.
6. **Rindzevičius R., Tervydis P., Narbutaitė L., Pilkauskas V.** Performance Analysis of Data Packet Transmission Network with the Unreliable Channels. *Electronics and Electrical Engineering*. – Kaunas: Technologija, 2008.– No. 4(84). – P. 53–58.

Received 2008 10 17

R. Rindzevičius, P. Tervydis. Performance Analysis of an Unreliable Queuing System with Buffer Threshold Control and a Reserved Channel // *Electronics and Electrical Engineering*. – Kaunas: Technologija, 2009. – No. 2(90). – P. 15–20.

We propose analysis of a data network node, which uses main and reserve transmission channels. Analytical analysis of a queuing system $M/M/2(N)K$ with unreliable main transmission channel and buffer threshold control is based on the Markov chains. The system has operation mode which is controlled by means of buffer threshold control strategy. Exact analysis of queues for finite system buffer with threshold control is implemented. The data packets loss probabilities and other main performance measures of queuing system are derived. Numerical results are presented to demonstrate the feasibility of the presented data packets transmission algorithms. Optimization problem is considered and numerical examples are presented. By tuning the buffer threshold, a compromise can be achieved between quality of data packet transmission and used channels throughput. Using proposed simulation of $G/G/2(N)K$ queuing system model and analytical $M/M/2(N)K$ system model it is possible to evaluate the system's performance measures. Ill. 12, bibl. 6 (in English; summaries in English, Russian and Lithuanian).

P. Риндзявичюс, П. Тервидис. Анализ производительности ненадёжной системы с очередью, с управляемым порогом буфера и резервным каналом // *Электроника и электротехника*. – Каунас: Технология, 2009. – № 2(90). – С. 15–20.

Предложена модель исследования узла сети передачи данных, использующего ненадёжный основной и резервный канал передачи пакетов данных. Анализ $M/M/2(N)K$ системы с очередью при ненадёжном основном канале основан на Марковских процессах. Система функционирует на основе регулирования порога заполнения буфера. Представлена точная аналитическая модель системы с конечной ёмкостью буфера. Вероятность потери пакетов данных и другие важные характеристики работы системы с очередью представлены в явном виде. Численные значения характеристик показывают возможности предлагаемого алгоритма для управления качеством передачи пакетов данных. Затронута проблема оптимизации системы. Управляя порогом заполнения буфера можно найти компромисс между качеством передачи пакетов данных и пропускной способностью каналов. На основе аналитической модели предложенной $M/M/2(N)K$ системы и имитационной модели $G/G/2(N)K$ системы легко оценить параметры передачи пакетов данных в системе. Ил. 12, библи. 6 (на английском языке; рефераты на английском, русском и литовском яз.).

R. Rindzevičius, P. Tervydis. Nepatikimos eiliavimo sistemos su valdomu buferio slenksčiu ir rezerviniu kanalu našumo analizė // *Elektronika ir elektrotechnika*. – Kaunas: Technologija, 2009. – Nr. 2(90). – P. 15–20.

Analizuojamas duomenų perdavimo tinklo mazgas, naudojantis nepatikimą pagrindinį ir rezervinį duomenų perdavimo kanalus. Eiliavimo sistemos su nepatikimu pagrindiniu kanalu ir valdomu baigtinio buferio užpildymo slenksčiu analitinis modelis $M/M/2(N)K$ paremtas Markovo procesais. Sistema funkcionuoja valdant buferio slenksčio lygį. Pateiktas tikslus baigtinės buferio talpos funkcionavimo analitinis modelis. Išvestos duomenų paketų praradimo tikimybės ir kitų sistemos darbą nusakančių charakteristikų tikslios matematinės išraiškos. Skaitiniai sistemos našumo rodikliai atspindi panaudoto duomenų perdavimo algoritmo galimybes. Keičiant sistemos buferio užpildymo slenksčio dydį, galima pasiekti kompromisą tarp duomenų paketų perdavimo kokybės ir perdavimo kanalų pralaidumo. Pasiūlytais $G/G/2(N)K$ sistemos imitaciniu ir $M/M/2(N)K$ sistemos analitiniu modeliais nesunku įvertinti tiriamosios eiliavimo sistemos našumo rodiklius. Il. 12, bibl. 6 (anglų kalba; santraukos anglų, rusų ir lietuvių k.).