

Strobology for the analysis of vibration modes of mechanical systems

R. Vasiliauskas*, **A. Palevicius****, **A. Busilas*****, **K. Pilkauskas******

**Mykolas Romeris University, Kaunas Faculty of Public Security, V. Putvinskio 70, 44211 Kaunas, Lithuania, E-mail: r.vasiliauskas@mruni.lt*

***Kaunas University of Technology, Mickevičiaus 37, 44244 Kaunas, Lithuania, E-mail: arvydas.palevicius@ktu.lt*

****Vilnius Gediminas Technical University, Saulėtekio al. 11, 10223 Vilnius, Lithuania,*

E-mail: alfredas.busilas@gama.vtu.lt

*****Kaunas University of Technology, Mickevičiaus 37, 44244 Kaunas, Lithuania, E-mail: kestutis.pilkauskas@ktu.lt*

crossref <http://dx.doi.org/10.5755/j01.mech.17.1.207>

1. Introduction

The holographic interferometry is used in vibration and modal analysis, structural analysis, composite materials and adhesive testing, stress and strain evaluation, and flow, volume/shape, and thermal analysis. All these applications derive from one or more of the four basic methods of the applied holographic interferometry: real-time, double exposure, time-average holography and strobology.

The first three holographic methods for investigating static and dynamic processes in various mechanical, electromechanical and microelectromechanical systems, the methodologies of the analysis of obtained interferograms are widely described in the literature, including [1 - 10]. Effectiveness of one or another method in solving specific problems is preconditioned by several factors - the form of analysed dynamic process (harmonic vibrations, multicomponent vibrations, random vibration processes, impact processes, etc.) the type of the desired information (qualitative or quantitative), conditions of the carried out experiment. In Fig. 1 the examples of interferograms, that are obtained using the methods of holographic interferometry - real-time, double exposure, time-average holography - for analysing and improving operation of the above systems and design solutions are presented.

In Fig. 1, a, b the interferograms of piezoelectric motion transducers obtained by the average-time method for various regimes of operation are presented. The transducers are excited by harmonic signals of different frequencies, so it is important to visualize the nature of the vibrations at different time moments of the vibration period.

The reliability of computer operation largely depends on hard disc housing deformations at different temperature regimes. The visualization of hard disc housing deformations, qualitative and quantitative assessment of the deformations is actual problem at development and design phases. The presented in Fig. 1, c interferogram of hard disc is obtained by the method of double exposure, under the changing temperature regime.

The object shown in Fig. 1, d presents the advances in the design of vibromotors using holographic interference methodologies [1]. The vibromotor itself is interpreted as a mechatronic system consisting of a piezoelectrical actuator and the driven object. The principle of design covers the areas of the application of standing deformation wave energy and propagating wave energy. The

specifics of vibromotors are achieving high precision levels in the motion of the driven object [11]. The only way for increasing the accuracy levels of vibromotors is exploiting specific geometric shapes of materials for the actuator and especially in the contacting zones. The method of laser holographic interference is used for determination and control of working characteristics of vibromotors (eigenshapes at appropriate resonance frequencies transfer of waves in the contact zones, etc.). The experimental data is later used as source data for numerical optimization of the design methods of vibromotors. The methods of holography interferometry are used for the extraction of objective experimental characteristics of the working regimes, what later gives the guidelines for optimisation of vibromotors' design. The applied methods of laser holography have to be different for the two working regimes. In the first case, when the output (driven) part is motionlessly fixed, it is possible to use the laser with continuous beam. In that case the method of realtime data processing is used, the motion of objects is averaged in time and time modulation is used (real-time strobology). That method can be applied, as the driven part is motionless, and the processes taking place in the contact zone between input and output links do not give rise to longitudinal motion, and do not affect the optical transformation. In case when the driven part is performing longitudinal motion (each of them can differ by its character) the holography method must use the following procedures - impulse holography with compensation of motion of the analysed object

Vibrational dispergator (holographic interferogram of actuator is presented in Fig. 1, e) consists of concentrically located cylinder shaped ultrasound processing chambers [1]. The cylindrical walls of the chambers are formed of piezoelectric actuators fed by the power sources. When the liquid is fed into the ultrasound processing chambers and the piezo-actuators start vibrating at their resonance frequencies, radial standing waves are generated around each actuator. The resonance frequency for the actuators is different and depends on radii of the actuators. Thus the flowing liquid is processed with higher frequency ultrasound every time it passes through the next processing ring. At the same time the high peak constant current actuators radiate high energy impulses to the processed liquid. Thus the whole process of dispergation turns to be more effective. The quality regulation of the dispergation may be performed by control of the level of constant voltage peak. It was proven experimentally that the effectiveness of the process is increased 3 times.

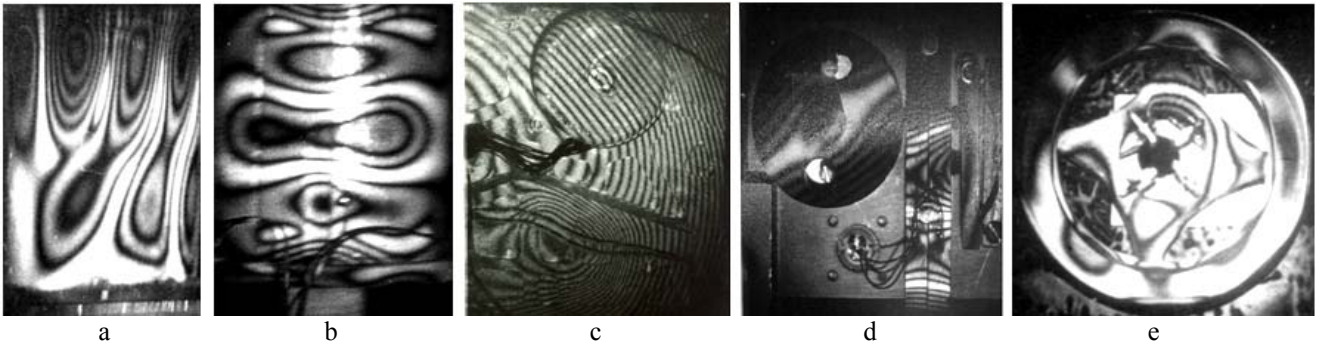

Fig. 1 Interferograms of piezoelectric motion transducers

Holographic interferometry is a powerful tool for the analysis dynamic of microelectromechanical systems [5, 8, 12 - 14]. It is a nondestructive whole field technique capable of registering microoscillations of MEMS components. There exist numerous methods used for the interpretation of patterns of fringes in the holograms of analyzed objects [15 - 17]. Unfortunately, sometimes straightforward application of these motion reconstruction methods (fringe counting technique, etc.) does not produce acceptable results. A typical example is holographic analysis of a micro-electromechanical switch which is described in [5].

The cantilever vibrations of microelectromechanical switch produce nonlinear effects in microstructure. Holographic interferogram of vibrating surface of such cantilever can not be evaluated straightforward using characteristic function for distribution interference fringes in case when time-average method for recording hologram is used. The characteristic function of the distribution of interference fringes of the vibrating surface should be chosen respectively to the nature of nonlinearities taking place in working regimes of microelectromechanical system.

A direct method to reduce the recording time during the pulsed illumination in stroboscopic holographic interferometry is suggested. The technique involves increasing the recording time while the object is in static position and decreasing the recording time during the pulsed illumination accordingly while the object is vibrating. The approach is applied to double-exposure and triple-exposure cases of stroboscopic holographic interferometry, where it is found that considerable reduction in the recording time is possible.

An experimental evaluation of a stroboscopic technique as applied to holographic interferometry is described. This technique is applicable in the analysis of vibrations with high amplitudes and complex wave forms and in the investigation of phase-dependent and nonsymmetrical effects.

2. Theoretical background of the methodology

For the analysis of vibrational processes of the objects, which are excited by harmonic and nonharmonic signals it is very important to carry out the qualitative and quantitative analysis of vibrations distribution on the surface within a single period [18, 19]. In this case, it is reasonable to use the strobography method. The paper presents the methodology of strobo pulse formation and synchronization with the corresponding vibration phase, allowing to increase the information generated by holographic interferograms and accuracy of the analysis. In

order to ensure optimal hologram exposure time (not more than 1 to 1.5 min) and information in the obtained interferograms it is necessary to select vibrations period filling by strobo pulses of the lowest possible duration given by the expression of T_1/k , where T_1 is period of excitation signal, which depends on the analysed object, and the value of which can be practically from 0.1 to 5 μs k is the number of strobo pulses.

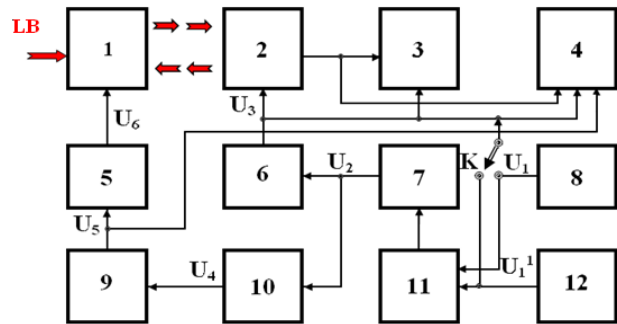

Fig. 2 Structural scheme of stroboscopic block: 1 - optical scheme with electro - optical modulator for obtaining holograms; 2 - analysed object; 3 - frequency meter; 4 - two-ray oscilloscope; 5 - strobo pulse amplifier; 6 - the scheme of excitation signal forming; 7 - the scheme of rectangular pulse forming and splitting (division factor 5, 2, 2); 8 - harmonic signal generator; 9 - the scheme of strobo signal front forming; 10 - the scheme of strobo pulse separation; 11 - the forming scheme of rectangular pulses with the period T_1 ; 12 - generator of non harmonic signals; Lb-laser beam; K - commutator of excitation signal of analysed object

In Fig. 2 the structural scheme of excitation signal formation, strobo pulse generation and synchronization with the desired vibration phase is presented. The signal from the generator of harmonic signals 8 or nonharmonic signal generator 12, through commutator K is transferred to the rectangular pulse forming scheme 11. The formed rectangular pulse signal the period of which corresponds the period T_1 of the excitation of signal of the analysed object is fed into the pulse splitting, counting and strobo pulse forming block 7. From this block, the signal is input into strobo pulse commutation and separation block 10 and the excitation signal forming block 6. The separated pulse, the duration of which may vary from 0.1 to 5 μs , is formed with the transfer characteristics ensuring the period of pulse fronts not higher than 10-15% of the minimum

strobo pulse duration by strobo pulse forming scheme 9. Strobo pulse amplifier 5 amplifies the strobo pulse up to the voltage needed to control electro – optical modulator.

Strobo pulse synchronization with the corresponding phase of excitation signal is illustrated by the diagram in Fig. 3

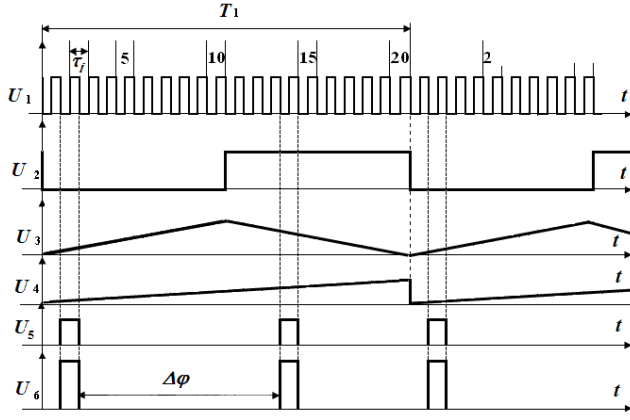

Fig. 3 Stobo pulse synchronization with the phase of corresponding excitation signal. T_1 - the period of the excitation signal of analysed object; τ_i - minimum duration of strobo pulse - $\Delta\varphi$ - phase shift between two strobo pulses during one period

The diagram shows the selection possibility of two strobo pulses: the first strobo pulse corresponds the start time of excitation signal; the second one is shifted in phase with reference to the first one. This methodology of strobo pulse formation has a number of advantages:

- the synchronization between strobo light pulse and the vibration phase of the analysed object is achieved throughout all the hologram exposure time;
- several strobo pulses of the necessary duration can be used for vibration analysis during one period of vibrations;
- strobo light pulse duration can be changed from T_1/k up to T_1/k .

$$\bar{I}(x, y) = \left| J_0(KA) + 2 \sum_{n=1}^{\infty} J_n(KA) i^n \right|^2 = \left| J_0(KA) + 2 \sum_{p=1}^n J_{2p}(KA) (-1)^p + 2 \sum_{p=1}^n J_{2p-1}(KA) \frac{(-1)^p}{i} \right|^2 \quad (3)$$

Taking into account $(-1)^p = \cos p\pi = \cos 2p \frac{\pi}{2}$

and $(-1)^p / i = i \sin \left[(2p-1) \frac{\pi}{2} \right]$ and using the features of

Bessel function [17]: $J_0(z) + 2 \sum_{p=1}^{\infty} J_{2p}(z) \cos 2p \frac{\pi}{2} = \cos(z)$

and $2i \sum_{p=1}^{\infty} J_{2p-1}(z) \sin \left[(2p-1) \frac{\pi}{2} \right] = i \sin z$, finally the

Eq. (3) can be expressed as:

3. Analysis of the obtained interferograms

The case is analysed where an object, any point of the surface of which in the direction of normal component vibrates in accordance with the law as described by the equation:

$$W(x, y, t) = A(x, y) \sin \omega t \quad (1)$$

and holographic interferogram is recorded with the help of short laser light pulses, which are synchronized with the maximum amplitude of the vibrating surface position.

The frequency of laser beam pulses, illuminating the object and the hologram at these moments in time is equal to the frequency of the object vibration $f_1 = \frac{\omega_1}{2\pi}$, while their minimum duration is $\tau_i = T_1/k_1$, where T_1 is the period of vibrations of the object under investigation; k_1 is the number of rectangular pulses forming the excitation signal (filling in the vibration period). Each of these pulses can be electrically selected as the strobo pulse. Then the center of strobing pulse will at the time instant $T_1/4 + m T_1$, where $m = 0, 1, 2, 3$ and the light intensity distribution in the obtained hologram can be described by the following equation [17]

$$\bar{I}(x, y) = \left| J_0(KA) + 2 \sum_{n=1}^{\infty} J_n(KA) \frac{\sin n\pi / k_1}{n\pi / k_1} i^n \right|^2 \quad (2)$$

where $\bar{I}(x, y)$ is intensity of recovered image of point (x, y) against the intensity at the point that during all the period of vibrations was in zero position; J_0, J_n are Bessel function of the first type of order 0 and n accordingly; K is sensitivity vector of holographic interferometer at the point (x, y) [2]; A is amplitude of the object surface vibration at the point (x, y) .

With this method of the object and hologram illumination, the reduction of strobo pulse duration significantly reduces the influence of the object displacements on the recovered image quality, but significantly prolongs the duration of the hologram exposure. Assuming $k_1 = \infty$, and then $\frac{\sin n\pi / k_1}{n\pi / k_1} = 1$, light intensity distribution is:

$$\bar{I} = |\cos(KA) + i \sin(KA)|^2 = 1 \quad (4)$$

Thus, recording the hologram with the help of very short light pulses, which are synchronized with the phase of harmonic vibrations the influence of the object's vibrations on the intensity distribution field of the reconstructed image is eliminated. However, with the very short strobo pulse duration, the exposure time of the hologram significantly increases. In order to determine the possibilities to eliminate these shortcomings the calculation of intensity distribution $\bar{I} = f(A/\lambda)$, at different values of k_1 is made according to formula (2), when illumination and ob-

servation directions are perpendicular (normal) to the object's surface.

In Fig. 4 the intensity distribution graph of the function $\bar{I} = f(A/\lambda)$ for various strobo pulse values is presented. It is known that human eye does not distinguish between light-intensity fluctuations, which are equal to or greater than 0.82. Taking this fact into account, it is possible to set such strobo pulse duration that for surface points of the object, vibrating with maximum amplitude the intensity \bar{I} value is not less than 0.82. In this case, visualizing

the reconstructed hologram of vibrating object, it will not be different from the hologram of nonvibrating object. From Fig. 3 it can be concluded that for low amplitudes of the tested object vibrations, which are usually investigated by the methods of holographic interferometry the above conditions are fulfilled at very short duration strobo pulses. Considering optimal exposure time of the hologram, informativeness of the interferograms, parameters of electronic part the number of strobo pulses k_1 is selected to be 20.

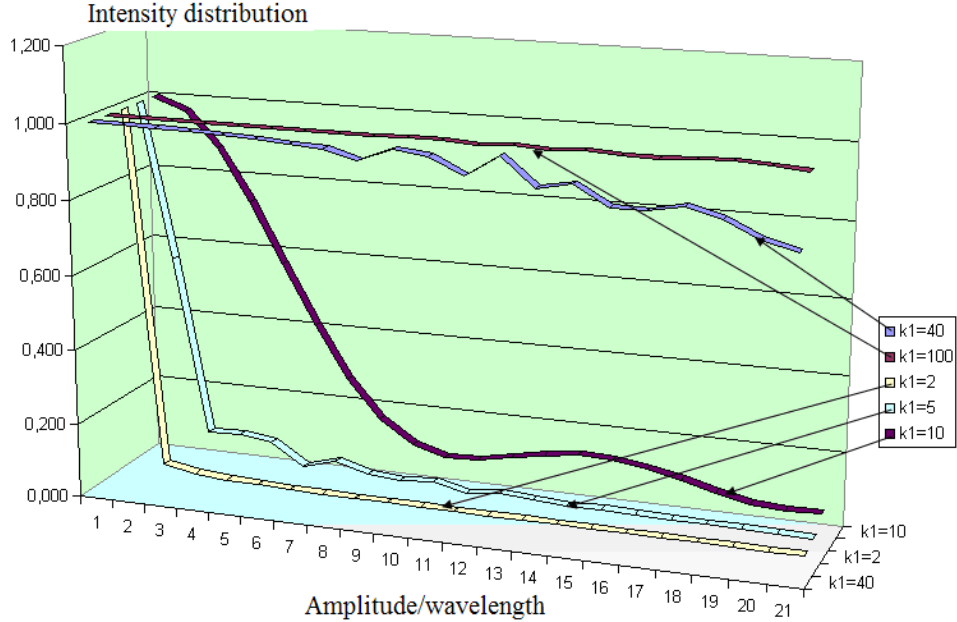

Fig. 4 Intensity distribution $\bar{I} = f(A/\lambda)$ graph of the reconstructed interferogram's image at different values of strobo pulses k_1 synchronized with the corresponding phase of the object's vibrations

When surface of the object at the same time is excited by several harmonic components, using the method of strobology makes it possible to investigate the influence of separate harmonic components of vibrations on the analysis of surface vibrations. By selecting the duration of strobo pulses in such a way that for surface points vibrating with a maximum amplitude $\bar{I} = f(A/\lambda)$ the value would be not less than 0.82, the image of reconstructed hologram practically will be not different from the image of nonvibrating object.

Under this conclusion the case where surface of the object at the same time vibrates by several harmonic components [8], each corresponding to its three-dimensional form of vibrations will be examined. In this case, position of each surface point of the object during the period can be described by the equation:

$$W(x, y, t) = A_1(x, y) \sin \omega_1 t + A_2(x, y) \sin(\omega_2 t + \theta) \quad (5)$$

where $A_1(x, y) \sin \omega_1 t$ and $A_2(x, y) \sin(\omega_2 t + \theta)$ are amplitude of vibration components of the point (x, y) the corresponding frequencies of which are $f_1 = \omega_1/2\pi$ or $f_2 = \omega_2/2\pi$; θ is phase shift of the component.

If interferogram of such a surface is recorded by strobo pulses with the duration of $\tau_i = T_1/k_1$ and the frequency f_1 , and synchronized with the vibrations amplitude position of the selected component $A_1(x, y) \sin \omega_1 t$ so taking into account the information in Fig. 4 always the strobing pulse duration can be chosen such a one that the indicated

vibration component practically will have no influence on the image of reconstructed interferogram. Then the approximate expression of characteristic function, describing the intensity distribution in the reconstructed interferogram will be conditioned only by the vibration component $A_2 \sin(\omega_2 t + \theta)$:

$$M\{A_2(t)\} \approx \frac{1}{T_e} \int_0^{T_e} \exp(i\varphi) dt \quad (6)$$

T_e is exposure time of the hologram, φ is phase of the light wave dissipated by the object's point (x, y) at the hologram's plane. As the sensitivity vector K of holographic interferometer at the point (x, y) is not a function of time the phase of light wave can be expressed as $\varphi = \varphi_0 + KA_2 \sin(\omega_2 t + \theta)$, where θ is phase shift of the second harmonic component and substituting in to Eq. (6) the following is obtained

$$M\{A_2(t)\} \approx \frac{e^{i\varphi_0}}{T_e} \int_0^{T_e} \exp[iKA_2 \sin(\omega_2 t + \theta)] dt \quad (7)$$

Expansion of the integrand expression (7) by Bessel function gives:

$$M\{A_2(t)\} \approx e^{i\varphi_0} / T_e \sum_{n=-\infty}^{\infty} J_n(A_2 K) e^{in\theta} \int_0^{T_e} e^{in\omega_2 t} dt \quad (8)$$

For the component $A_2 \sin(\omega_2 t + \theta)$ the phase of strobo pulse will be shifted by the value δ , where $0 < \delta < 1$ is a part of the period T_2 in which the strobo pulse is located. In this case, integral limits at the hologram exposure will be from $\delta T_2 - \tau_i/2$ up to $\delta T_2 + \tau_i/2$ and taking into account that the midpoint of strobo pulse in case of the component $A_2 \sin(\omega_2 t + \theta)$ will correspond the random phase of vibration $\omega_2 \delta T_2$ and assuming the strobo pulse duration equivalent to the hologram exposure duration during a single period $\tau_i = T_c$ the following expression is obtained:

$$M \{A_2(t)\} \approx e^{i\phi_0} \sum_{n=-\infty}^{\infty} J_n(A_2 K) e^{in\theta} \frac{\sin(n\pi/k_1)}{n\pi/k_1} e^{in2\pi\delta} \quad (9)$$

It is worth mentioning that the period of strobo pulses is T_s and in general case $T_s \neq \eta T_2$ and the fact is that in dependence on the frequency ratio the value $0 < \delta < 1$

$$M \{A_2(t)\} = e^{i\phi_0} \left[J_0(KA_2) + 4 \sum_{p=1}^{\infty} J_{2p}(KA_2) \frac{\sin \frac{2p\pi}{k_1}}{2p\pi/k_1} \cos 2p\theta \times \right. \\ \left. \times \sum_{j=0}^{\infty} \cos 2\pi 2p\delta_j + 4i \sum_{p=1}^{\infty} J_{2p-1}(KA_2) \frac{\sin \frac{(2p-1)\pi}{k_1}}{(2p-1)\pi/k_1} \cos(2p-1)\theta \sum_{j=0}^m \sin 2\pi(2p-1)\delta_j \right] \quad (11)$$

From the expression of characteristic function a conclusion can be made that applying the proposed method of strobo pulse formation and synchronization with the necessary vibration phase, the intensity of the reconstructed image described by this function depends on duration of the strobo light pulse and on the ratio of parameters of different vibration components.

Let us analyse Eq. (12) when frequency ratio of vibration components is irrational number. Recalling the fact – if $f_2 > f_1$ and $f_2/f_1 = q + \delta$, where $q = 1, 2, 3, \dots$, $0 < \delta < 1$ the strobo pulses during exposure time will be repeated with the period $T_1 = T_2(q + \delta)$. Evaluating all the

facts above and changing summation with respect to δ in expression (11) by integration will give:

$$M \{A_2(t)\} \approx e^{i\phi_0} J_0(KA_2) \quad (12)$$

Thus when frequency ratio of the vibration components is irrational number the proposed methodology ensures visualization of time averaged interferogram of vibration form for one of the vibration components of the tested object. Fig. 5 presents an example of the obtained result for a tested plate natural frequencies of which are equal to 379 Hz and 2381.3 Hz.

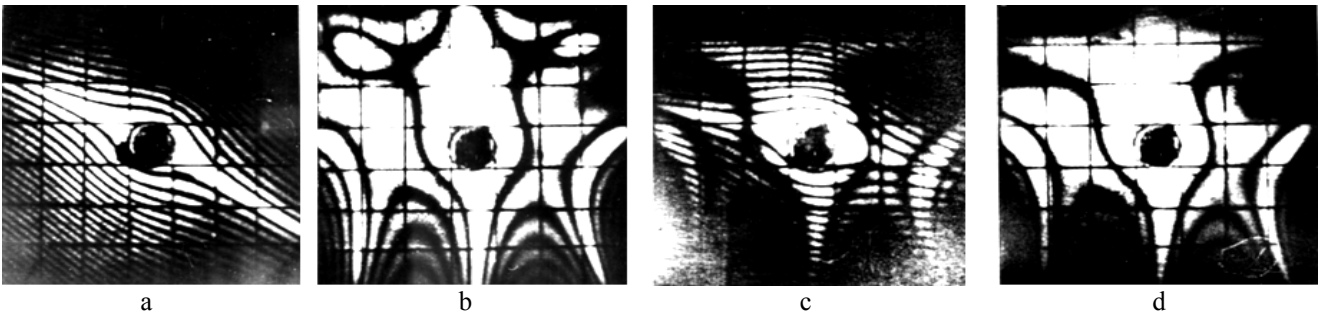

Fig. 5 Separation of the plate's vibration forms: a - $f_1 = 379.0$ Hz; b - $f_2 = 2381.3$ Hz; c - time average hologram; d - strobo pulse frequency $f_1 = 379.0$ Hz

Fig. 5 presents separation of the plate's vibration forms which correspond two vibration components of different frequencies when the ratio of vibration frequencies is irrational number: a, b - interferograms obtained by time average method representing vibration forms of the plate at $f_1 = 379.0$ Hz and $f_2 = 2381.3$ Hz; c - interferogram of vibration form of the plate obtained by time average method when the plate simultaneously vibrates at the two frequencies $f_1 = 379.0$ Hz and $f_2 = 2381.3$ Hz; d - interferogram of the plate's vibration form corresponding the vibration

component the frequency of which is f_2 when the plate simultaneously vibrates at the two frequencies $f_1 = 379.0$ Hz and $f_2 = 2381.3$ Hz obtained by the method of strobo holography.

Let us analyse equation (12) when frequency ratio of vibration components is rational number. It is assumed that $f_2 > f_1$ and $f_2/f_1 = q$, where $q = 2, 3, \dots$. In this case period T_2 of the component with the frequency f_2 will be covered within the period T_1 so that $T_1/T_2 = q$ is a whole number and in this case strobo pulse duration for the compo-

nent with the frequency f_2 per period will be $\tau_{12} = T_2/k_1 = T_1/qk_1$. Total time of hologram expose in this case will be $n\tau_{12}$. Intensity distribution of the recovered hologram in such a case is described by Eq. (8) which after evaluation of strobo pulse duration, total exposure time of the hologram and making the necessary rearrangements will take the same form as Eq. (12). It is obvious that this

expression will be correct only I case when the number of strobo pulses during hologram exposure time is significantly greater than the frequency ratio q of the vibration components. Fig. 6 presents an example of the obtained result when a plate natural frequencies of which are equal to 379 Hz and 2381.3 Hz was tested.

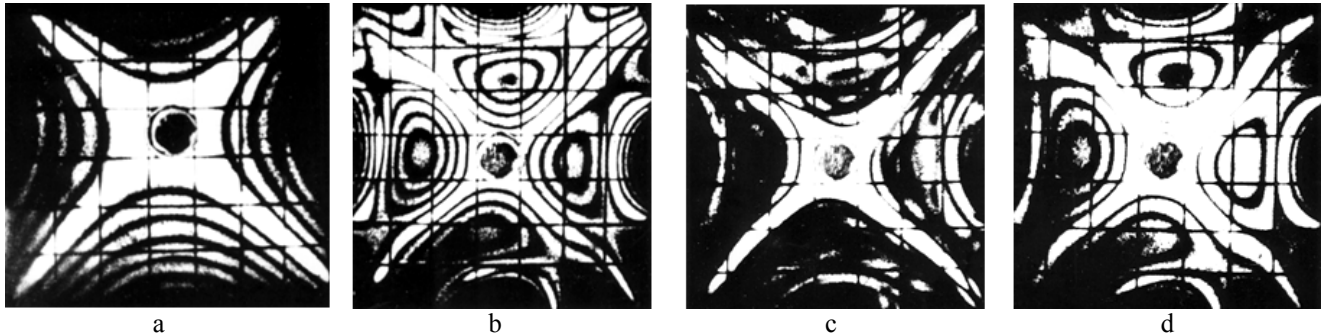

Fig. 6 Separation of the plate's vibration forms which correspond two vibration components of different frequencies: a - $f_1 = 764.0$ Hz; b - $f_2 = 7640.0$ Hz; c - time average hologram; d - strobo pulse frequency $f_1 = 764.0$ Hz

Fig. 6 presents separation of the plate's vibration forms which correspond two vibration components of different frequencies when the ratio of vibration frequencies ($f_2/f_1 = 10$) is rational number. a, b - Interferograms obtained by time average method representing the plate's vibration forms at $f_1 = 764$ Hz and $f_2 = 7640$ Hz; c - interferogram of vibration form of the plate obtained by time average method when the plate simultaneously vibrates at the two frequencies $f_1 = 764$ Hz and $f_2 = 7640$ Hz; d - interferogram of the plate's vibration form corresponding the vibration component the frequency of which is f_2 when the plate simultaneously vibrates at the two frequencies $f_1 = 764$ Hz and $f_2 = 7640$ Hz obtained by the method of strobo holography.

4. Concluding remarks

1. The methodology of strobo light pulses formation allowing one or several light pulses to separate and synchronize with the phase of excitation signal of the tested object in one period of its vibration during the whole duration of the hologram exposure is presented.

2. For the analysis of vibrations several strobo pulses during one period of the vibration can be used and duration of the strobo light pulse can be practically changed from $T_1/2$ up to T_1/k_1 .

3. The methodology of component separation of 3D vibration with two different frequency components is theoretically proven for the cases of various frequency ratios of the components.

References

1. **Palevičius, A.; Ragulskis, K.; Vasiliauskas, R.; Bulbulis, A.** 2008. Historical aspects and future perspective of holography in Lithuania. The Society for Experimental Mechanics. Proceedings of the International Symposium to Commemorate the 60th Anniversary of the Invention of Holography. Sheraton Springfield Monach Place Hotel, Springfield, Massachusetts USA, October 27 – 29: 368-377.
2. **Palevičius, A.; Vasiliauskas, R.** 1998. Application of laser interferometry and holographic methods for analysis and design of vibrational systems. *Virpesių mechanika ir technika. Vibroengineering: monografija.* Lietuvos Mokslų akademija. -Vilnius: Lietuvos mokslas, kn. 19: 358-381.
3. **Vasiliauskas, R.; Palevičius, A.; Ragulskis, K.** 1988. Analysis of holographic interferograms by ultrasonic piezoelectric transducers in the investigation of three-dimensional vibrations, *Acoustical Physics* 34(6): 573-575.
4. **Patašienė, L.; Vasiliauskas, R.; Fedaravičius, A.** 2005. Application of holographic interferometry methods for analysis piezodrives with ring actuators, *Ultragarsas* 3(56): 17-21.
5. **Ostasevičius, V.; Palevičius, A.; Daugela, A.; Ragulskis, M.; Palevičius, R.** 2004. Holographic imaging technique for characterization of MEMS switch dynamics. *Proc. SPIE Vol. 5389, Smart Structures and Materials 2004: Smart Electronics, MEMS, BioMEMS, and Nanotechnology*; Vijay K. Varadan; Ed.: 73-84.
6. **Patašienė, L.; Vasiliauskas, R.; Fedaravičius, A.** 2007. Holographic interferometry method for determination of layer piezostack parameters, *Ultragarsas* 1(6)2: 23-25.
7. **Palevičius, A.; Busilas, A.; Vasiliauskas, R.** 2008. Analysis holographic interferogram of links of vibrating systems, *Journal of Vibroengineering (Vibromechanika)*, 2008 June. -Vilnius, Lithuania, volume 10, ISSUE 2, numbers of publications from 348 to 370: 245-250.
8. **Vasiliauskas, R.; Palevičius, A.** 2008. Analysis of holographic interferometry of microelectromechanical system with non harmonic cycles excitation, *Journal of Vibroengineering (Vibromechanika)*, January/March. Vilnius, Lithuania, vol. 10 ISSUE 1, numbers of publications from 326 to 347: 42-46.
9. **Patašienė, L.; Fedaravičius, A.; Vasiliauskas, R.** 2008. Holographic interferometry methods for analysis and design of rotary converter, *Journal of Vibroengineering (Vibromechanika)*, January/March. -Vilnius,

- Lithuania, vol. 10, ISSUE 1, numbers of publications from 326 to 347: 33-36.
10. **Ragulskis, K.; Dabkevičius, A.; Kibirkštis, E.; Bivainis, V.; Miliūnas, V.; Ragulskis, L.** 2009. Investigation of vibrations of a multilayered polymeric film, *Mechanika* 6(80): 30-36.
 11. **Mažeika, D.; Bansevicius, R.** 2009. Study of resonant vibrations shapes of the beam type piezoelectric actuator with preloaded mass, *Mechanika* 2(76): 33-37.
 12. **Tonin, R.; Bies, D.A.** 1978. Time-average holography for the study of three-dimensional vibrations, *Journal of sound and vibrations* 52: 315.
 13. **Vikram, C.S.** 1974. Stroboscopic holographic interferometry of vibration simultaneously in two sinusoidal modes, *Optics communications*, v.II, Nr.4: 360-364.
 14. **Shajenko, P.; Johnson, C.D.** 1968. Stroboscopic holographic interferometry, *Appl. Phys. Lett.* 13(1): 44-46.
 15. **Harris, J.S.; Fusek, R.L.; Marcheski, J.S.** 1979. Stroboscopic interferometer, *Appl. Opt.* 18: 2368-2371.
 16. **Zarucki, MA.; Gurevich, V.S.** 1986. On research of vibration characteristics of the parts with stress concentrators by the method of stroboscology. In textbook: *Stress Concentration in the Elements of Aviation Engines*. Inter university research materials. Ufa aviation Institute of S. Ordzonikidze: 97-100 (in Russian).
 17. **Vest, Ch.** 1982. Holographic interferometry. Editor in chief J.S. Ostrovski. Moscow: Mir. 504p. (in Russian)
 18. **Lee, Y-S.; Kim, S-H.; Skibniewaki, M.J.** 2009. Analytical and experimental approach for assessing vibration serviceability of highway bridges due to heavy vehicle traffic, *The Baltic Journal of Road and Bridge Engineering* 4(3): 123-133.
 19. **Bayraktar, A.; Birinci, F.; Altunışık, A.C.; Türker, T.; Sevim, B.** 2009. Finite element model updating of Senyuva historical arch bridge using ambient vibration tests, *The Baltic Journal of Road and Bridge Engineering* 4(4): 177-185.

R. Vasiliauskas, A. Palevičius, A. Busilas, K. Pilkauskas

MECHANINIŲ SISTEMŲ VIRPESIŲ KOMPONENČIŲ ANALIZĖ STROBO HOLOGRAFIJOS METODU

Re z i u m ė

Straipsnyje pateikiama interferogramų gavimo ir analizės metodika, pagrįsta strobolografinių objektų erdviųjų virpesių, kurių forma yra sąlygojama vieno ar dviejų dažnių harmoninio ar neharmoninio virpesių sužadinančio signalo, tyrimu. Pateikiamas šviesos strobavimo impulso formavimo ir sinchronizavimo su pasirinkta tiriamojo objekto virpesio fazė būdas, užtikrinantis sinchronizavimo stabilumą. Pateikiama gautų interferogramų analizės metodika, įvertinanti strobavimo impulsų ir visos hologramos ekspozicijos trukmę. Analizuojami objekto virpesio komponentų išskyrimo atvejai, pateikiami rezultatai, gauti esant racionaliam ir iracionaliam virpesio komponentų dažnių santykiui.

R. Vasiliauskas, A. Palevičius, A. Busilas, K. Pilkauskas

STROBOHOLOGRAPHY FOR THE ANALYSIS OF VIBRATION MODES OF MECHANICAL SYSTEMS

S u m m a r y

The paper presents the methodology for obtaining holograms by the methods of stroboscology and techniques for their analysis when three-dimensional vibrations of an object are conditioned by the signal of one or two harmonic frequencies or non harmonic signal. A method of strobo light pulse formation and synchronization with the selected phase of oscillations to ensure a robust and stable synchronization is presented. The methodology for analysis of the obtained holograms evaluating the duration of strobo pulses and the hologram exposure time is presented. The cases of the separation of vibration components of the object are analyzed, the results obtained with the rational and irrational ratios of the oscillation frequencies are presented.

Р. Василяускас, А. Палявичюс, А. Бусилас, К. Пилкаускас

ИСПОЛЬЗОВАНИЕ МЕТОДА СТРОБО ГОЛОГРАФИИ ПРИ АНАЛИЗЕ КОМПОНЕНТ КОЛЕБАНИЙ МЕХАНИЧЕСКОЙ СИСТЕМЫ

Р е з ю м е

В статье представлена методика получения и анализа интерферограмм, использующая метод стробо голографии при исследовании объектов, пространственная форма колебаний которых обусловлена одночастотным или двухчастотным гармоническим или негармоническим сигналом, возбуждающим колебания объекта. Представлен способ формирования и синхронизации стробирующего светового импульса с определенной фазой колебания исследуемого объекта, обеспечивающий жесткую и стабильную синхронизацию. Описана методика анализа полученных интерферограмм, оценивающая длительность стробирующего светового импульса и длительность экспонирования интерферограммы. Проведен анализ частных случаев выделения отдельных компонент колебаний исследуемого объекта, представлены полученные результаты при рациональном и иррациональном соотношении частот компонент колебаний исследуемого объекта.

Received October 06, 2010

Accepted January 28, 2011