

Facility for catalysts testing, research of CuO / γ - Al₂O₃ coatings

A. Babilius*, K. Babilius**, R. Melkūnas***, K. Buinevičius****

*Kaunas University of Technology, Kęstučio 27, 44312 Kaunas, Lithuania, E-mail: arturasbabilius@gmail.com

**Kaunas University of Technology, Kęstučio 27, 44312 Kaunas, Lithuania, E-mail: kazys@topolis.ktu.lt

***Kaunas University of Technology, Donelaičio 20, 44239 Kaunas, Lithuania, E-mail: regiman.melk@gmail.com

****Kaunas University of Technology, Donelaičio 20, 44239 Kaunas, Lithuania, E-mail: kestutis.buinevicius@ktu.lt

1. Introduction

Emission control regulations have been introduced in all industrialized countries in order to reduce the emissions of vehicles powered by internal combustion engines. The pollutants that are limited today are carbon monoxide (CO), hydrocarbons (HC), oxide of nitrogen (NO_x) and particulate matter (PM) [1].

Atmospheric NO_x, which primary consist of NO and NO₂, results in air pollution and the production of acid rain. NO₂ has been linked to bronchitis, pneumonia, and alteration of the immune system. It is also responsible for acid rain and urban smog. NO_x also participates in the formation of ground-level ozone in the presence of sunlight. Industrial and others combustion processes (e.g. automobiles) produce large amounts of NO_x, which is a severe treat to the environment [2].

The requirements of Europe Union directive 2001/80/EC and the limitations of emissions of certain pollutants into the air from stationary combusting plants witch take effect in Lithuania, also the requirements of "Best Available Technologies"(BAT) lead us to seek for effective ways of pollutants reducing [3].

Toxic nitrogen oxides (NO_x) are generated during a combustion process. Almost all industrial boilers in Lithuania do not meet the requirements of BAT. Technological implements of combustion can reduce the formation of NO_x; however, in many cases these implements are insufficient or can not be applied with the boilers currently used. Another method for removing NO_x from combustion products is to use selective catalysts. Processing of flue gas from industrial boilers in catalysts is one of the ways for decreasing the pollution level of NO_x and CO. Such a method is usual in automobiles and is based on the conversion of NO and CO in a chemical reaction such as $\text{NO} + \text{CO} + \text{catalyst} \Rightarrow 0.5\text{N}_2 + \text{CO}_2$.

Classical TWCs were constituted by a mechanically resistant honeycomb monolith of cordierite with a low thermal expansion coefficient; however they had a low specific surface area and for this reason monolith surfaces are covered with a washcoat which is composed classically of alumina. The most widely aluminas used as carriers are γ - Al₂O₃ or η - Al₂O₃, which have high specific surface areas and are relatively stable. Finally noble metal and additives are impregnated in to washcoat surface. Common noble metals are platinum and rhodium because of their high selectivity and conversion in carbon monoxide and hydrocarbon oxidation, and in nitrogen oxides reduction, respectively [4].

Since the temperature in exhaust gases may be as low as 200°C for small engines, and can exceed 600°C at full load for heavy engines, a useful catalysts has to oper-

ate efficiency at low temperatures and be thermally stable [5].

However, the use of automobile catalysts may not be perspective deal due to the high price of catalysts, made of precious metals.

Copper catalysts have been extensively used in several processes related to nitrogen oxides elimination, mainly due to the low cost compared with noble metals and the good performance of these systems with different reducing agents such as CO, hydrocarbons and ammonia. The photocatalytic decomposition of NO, DeNO_x - DeSO_x process, decomposition of N₂O and NO, and the oxidation of NO to NO₂, are some other processes where these systems have shown excellent results [6].

Catalytic coatings supported on ceramic monoliths can be obtained by using various methods. CuO/ γ - Al₂O₃ oxide coatings, excluding other possible methods, can be formed on steel plates at low temperatures, without formation of an under layer, using activated thermochemical condensate deposition method (AT - CCD) which provides the layout coatings with new features [7].

Together with the basic testing conditions, catalytic coatings can be tested in specific facilities for catalyst testing, which exclude the usual methods applied for testing of coatings [8, 9].

The main goal of the research work was to investigate the possibility of applying catalysts made of cheap material for industrial boilers. Such catalysts should satisfy the following requirements: proper mechanical resistance, low price and adjustable technologies. The usage of catalysts, made of copper oxides, could satisfy most of such requirements.

The aim of this research work:

1. to investigate the adhesion, resistance for long-term chemical effect in acids, phase composition, crystallite dimensions, surface morphology and chemical composition of CuO/ γ - Al₂O₃ coatings, obtained applying the method of activated thermochemical condensate deposition and thermally processed at the temperature of 650°C;
2. to design a test facility for catalyst testing and investigate its main parameters;
3. to analyze CuO/ γ - Al₂O₃ catalysts monoliths thermally processed at the temperature of 650°C and compare it with Pt/cordierite catalysts monoliths by determining the conversion of carbon and nitrogen oxides under conditions of different oxygen concentrations at the inlet to the catalytic converter.

2. Materials and experimental procedure

CuO/ γ - Al₂O₃ oxide coatings were obtained on

the steel OC-404 plates of 50 μm thickness by the activated thermo-chemical condensate deposition method, without formation of an under layer, at the temperature of 250°C.

The samples of $\text{CuO}/\gamma\text{-Al}_2\text{O}_3$ coatings were thermally treated at the temperature of 650°C. The heating rate was 10°C/min up to the defined temperature. The samples were kept at this temperature for 4 hours and were cooled together with the furnace.

For the coated and thermally processed specimens the adhesion measurements were done using “scratch” method [10].

Investigations for the long-term resistance in 20% solutions of acid HCl and HNO_3 mixture (ratio 3:1) were done as well.

Determination of the materials phase composition (XRD) was done by using device DRON - 6 and applying PDF - 2 data base [11].

By using SEM - EVO 50 (method of energy dispersion spectrometry and analysis of elements) the surface morphology and composition of elements were investigated. The results of analysis were received by detector INCA_x - sight, EDS (energy dispersion spectrometer).

Determination of chemical elements composition the ceramics catalyst was done using massspectrometer Perkin-Elmer 403 (atomic absorption method). Determinations of crystallites size in the system “coating - substrate” were performed using X - fit program [12].

Catalytic experiments were done using made-up catalysts experiments device. There were tested two different catalytic converters embedded in the catalytic reactor. The first converter: is a strip of metal, coated from the both sides, rolled in the form of cylinder (catalytic blocks) and having gas channels. The diameter of catalytic block – 40 mm, the length – 50 mm. The converter consist of two blocks. The second converter – for the comparison: two blocks with the same dimensions Pt/cardierite type TWC classical ceramics catalytic blocks.

The dimensions, volume, and general geometric area of the catalytic wall of the two catalysts monoliths

forming the converter are such:

$$D = 40 \times L \quad [50 + 50] \text{ (mm)}, \quad V = 125.0 \text{ cm}^3, \\ S = 0.40 \text{ m}^2;$$

Heating of catalysts monoliths were performed up to 600°C.

The parameters of gas flow at inlet to the catalysts monoliths are: $\text{CO} = 4000 \text{ ppm}$, $\text{NO}_x = 40 \text{ ppm}$, $\text{CO}_2 \sim 13.6\%$, $\text{O}_2 = 1.2\%$, 0.6% and 0.2% respectively, gas flow rate - $Q_g = 2.75 \text{ l/min}$. The analysis of fume was made by gas analyzers Ecoline 6000 and Gazochrom 3101.

3. Results and discussions

Coatings, obtained by the activated thermo-chemical condensate deposition method and thermally processed at temperature of 650°C, have a good adhesion-28 N. This result is good for the catalysts due to ceramic coating was formed on steel substrate without underlayer, which properties must satisfy not only thermo mechanical but also catalysts requirements. The coated samples (in comparison with the samples without coatings) decompose during a longer period of time. Samples (metal plates without coatings) are destructed in 20% solution of acids HCl and HNO_3 (relation 3:1) in rather short time (4 hours) even in the case of thermal processing (metal plates with coatings) at the temperature of 650°C (26 hours). This result is good for the catalysts because they must work not only in thermal cyclical conditions but also in thermo chemically aggressive environment without a possibility to change their functional – exploitation properties in time.

In addition to this, XRD tests of the “substrate-coating system” (Fig. 1) and the determination of crystallite size were made (Fig. 2). Three phases exist at 650°C temperature: metal phase of substrate Fe - Cr (crystallites 170 nm) and phases of oxides: high specific surface area containing $\gamma\text{-Al}_2\text{O}_3$ (crystallites 7 nm) and catalytic - CuO (crystallites 21 nm). There are no other types of phase in the system “coating – substrate”.

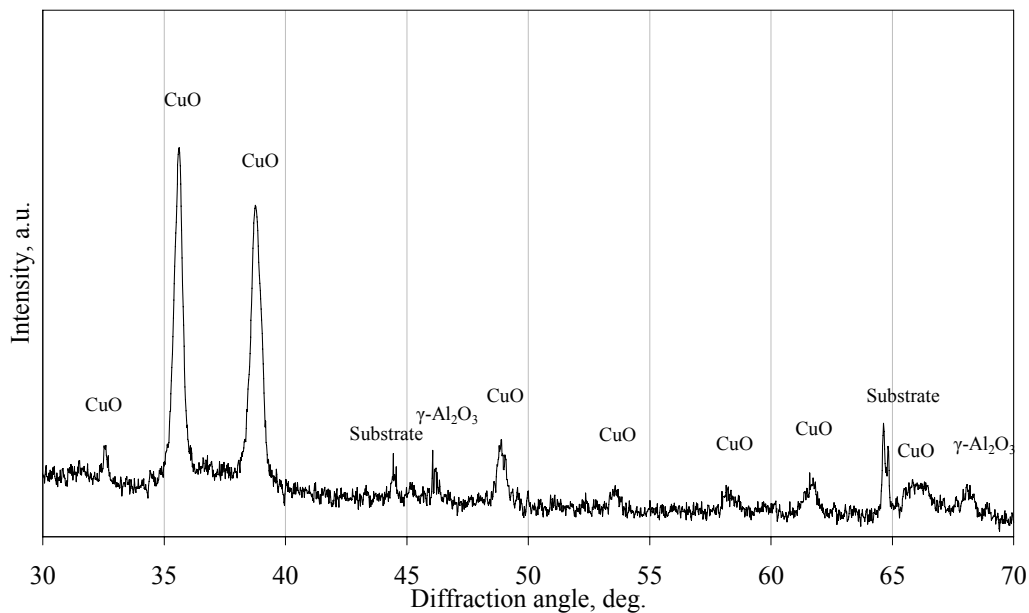

Fig. 1 XRD patterns of a system “ $\text{CuO}/\gamma\text{-Al}_2\text{O}_3$ coating - substrate”

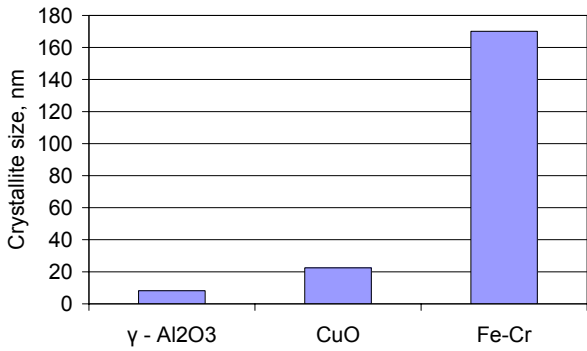

Fig. 2 Crystallite size in the system "CuO/γ-Al₂O₃-substrate"

The SEM topographic picture presents CuO/γ - Al₂O₃ coating obtained applying the method of the activated thermo-chemical condensate deposition and thermally processed at the temperature of 650°C (Fig. 3).

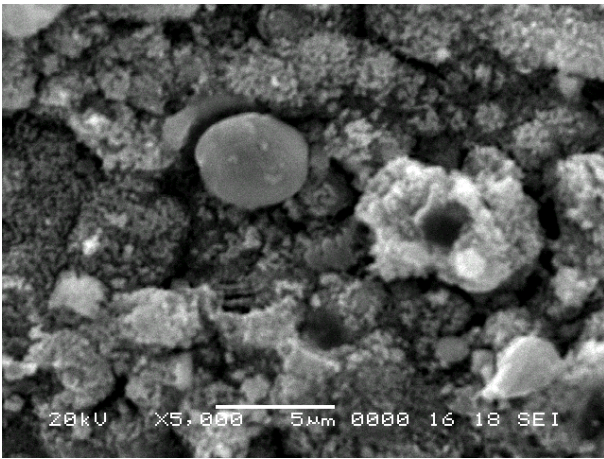

Fig. 3 Typical surface of CuO/γ - Al₂O₃ coating

The coating possesses a microrelief, where CuO

and γ-Al₂O₃ phases are well observed together with their relative sizes, amounts, shapes and interposition.

Testing chemical composition of the coating surfaces and using SEM - EDS method chemical composition was determined the 59% amount of Cu (Fig. 4) was noticed.

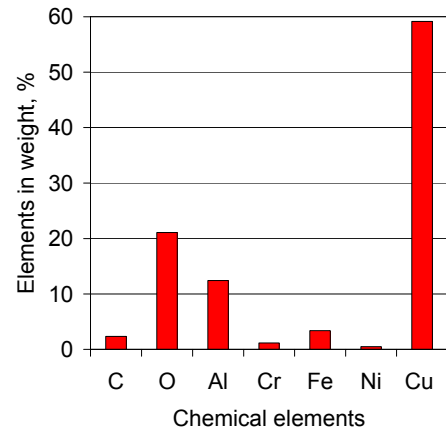

Fig. 4 Distribution of chemical elements in the system "CuO/γ-Al₂O₃-substrate"

Seeking to compare CuO/γ - Al₂O₃ catalysts and Pt/cordierite catalysts (Pt/Mg₂Al₄Si₅O₁₈) two catalysts monoliths from second catalyst converter were chosen. This ceramic was soaked with additional elements (Table).

Table
Amounts chemical elements additionally soaked in ceramic cordierite (Mg₂Al₄Si₅O₁₈)

Chemical elem.	Pt	Rh	Sn	Zn
%	0.18	0.008	0.21	0.005

Aiming to conduct comparative tests of NO_x and CO conversion, a special facility for catalyst testing was designed and its principle diagram is displayed in Fig. 5.

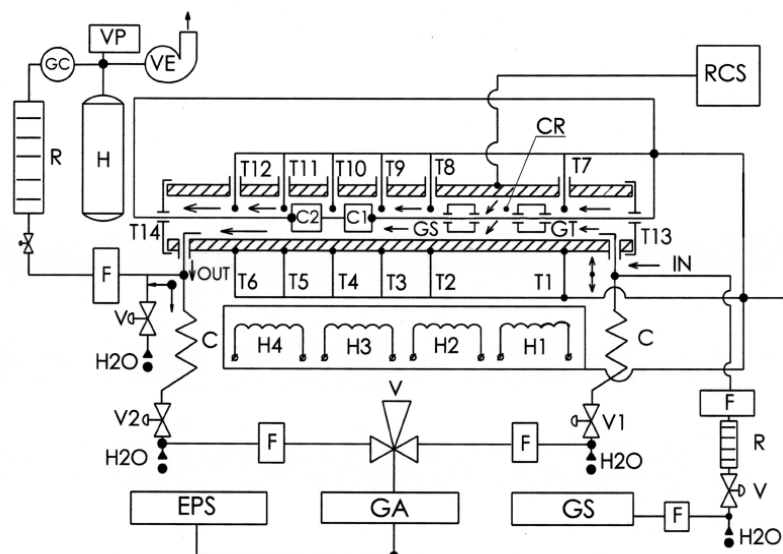

Fig. 5 Basic diagram of catalysts testing facility: GS – gas source, F - filter, C – gas cooler, R - rotameter, CR – catalytic reactor, GT – gas flow turbulizer, GS – gas flow stabilizer, C1 and C2 – catalysts monoliths, GC- gas flow counter, VP – vacuum pump, GA – gas analyzer, V - valve, EPS – electric control system of parameters, H - heater, T – thermocouple, RCS – reactor cooling system, H – vacuum chamber, P – gas pressure meter, VE - blower

Two types of catalysts monoliths were investigated in the testing facility: a) $\text{CuO}/\gamma\text{-Al}_2\text{O}_3$ and b) $\text{Pt}/\text{Mg}_2\text{Al}_4\text{Si}_5\text{O}_{18}$ (Pt/cardierite, TWC classical catalysts monolith) (Fig. 6).

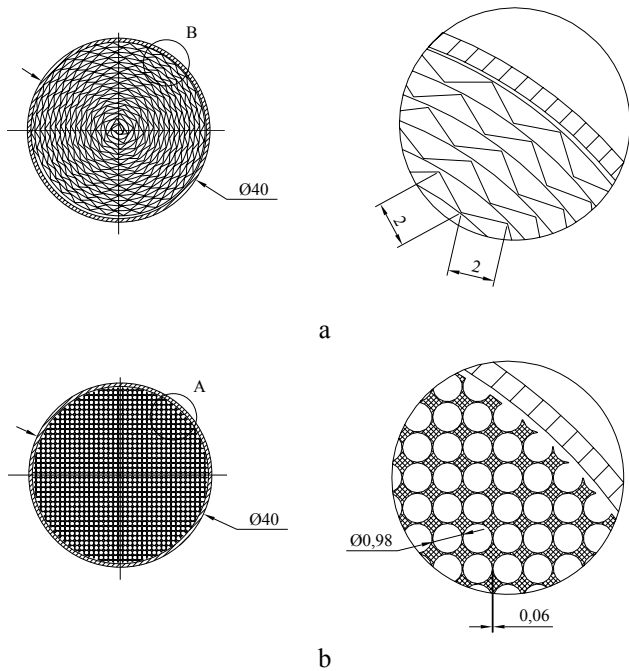

Fig. 6 Cross-section of: a - $\text{CuO}/\gamma\text{-Al}_2\text{O}_3$ and b - $\text{Pt}/\text{Mg}_2\text{Al}_4\text{Si}_5\text{O}_{18}$ catalysts monoliths

Applying the testing facility it is possible:

1. to make catalytic tests by heating gas flow up to 650°C ;
2. to investigate the gas flow passing through catalysts monoliths from 1.5 to 15.0 l/min;
3. to retain a steady temperature in all the sector where catalysts monoliths are placed;
4. to change heating speed in separate parts of heated sector of the catalytic reactor;
5. to change the composition of the flue gas incoming into the testing sector also to inject extra gas to any part of the heated sector of the catalytic reactor;
6. to perform gas analytic measurements at any part of heated sector of the catalytic reactor.

Structural peculiarities of the facility for catalyst testing and the principle of functioning.

The gas flow of fixed and controlled composition from combustion chamber (GS) goes into the catalytic reactor (CR), passes the gas flow turbulizer (GT) and the gas flow stabilizer (GS). Then the flue gas moves through the tested catalysts monoliths (C1 and C2) which are mounted in the reactor and after changing its chemical composition is sucked out through the catalytic reactor chamber outlet using the vacuum pump (VP). The gas flow is controlled to ensure the designed flow rate counted by the gas flow counter (GC). The analysis of chemical gas composition at the inlet to the catalytic monoliths and the outlet from the catalytic monoliths is performed at discrete intervals of time, applying the gas analyzer (GA) and commuting the valves (V1 and V2) respectively. Results were captured three times within the periods of 30s when the temperature was constant. The temperature field along all the tracts was controlled by the heaters (H1 - H4) of the electric control system (EPS), and the temperature was measured by ther-

mocouples (T1- T14). Using the thermosondes there was a possibility to inject additional gas or to pump the gas for the analysis of the different parts of the reactor.

Fig. 7 clearly presents the influence of the current heating value on the heating speed within the interval of 10 hours when the maximum temperature is reached in the outlet from the catalytic monolith and is characteristic to the stationary cooling of the catalytic reactor without gas flow. Fig. 8 shows that the temperature field of reactor depends on the heating current (4 A, 5 A and 6 A). The optimum heating current of 6 A was selected.

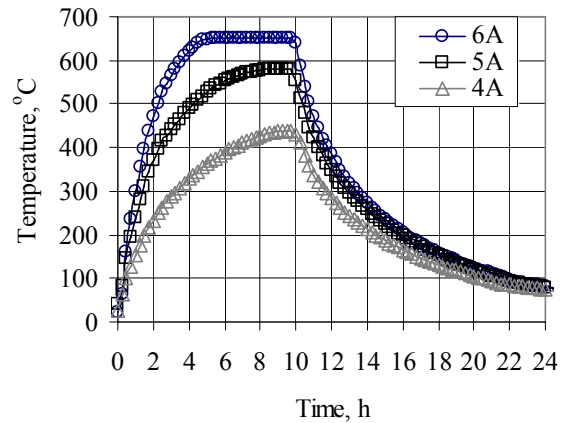

Fig. 7 Heating current dependency on point T11 temperature

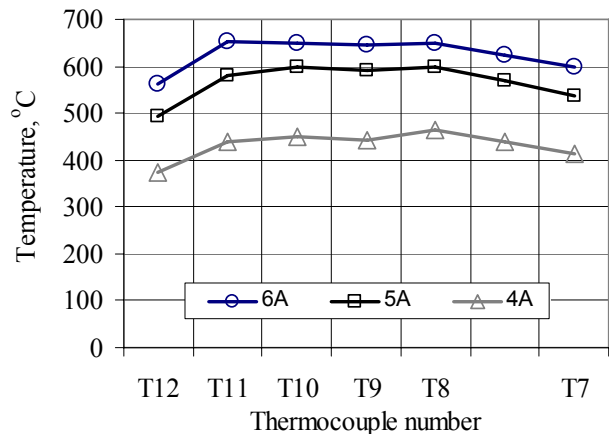

Fig. 8 Reactor's temperature dependency on heating current

Catalytic tests of monoliths.

The catalytic investigation of NO_x and CO conversion was conducted while making comparison of $\text{CuO}/\gamma\text{-Al}_2\text{O}_3$ types of two catalytic monoliths with two Pt/cardierite type TWC classical catalysts monoliths of the same dimensions. The tests were performed with 1.2, 0.6 and 0.2% oxygen concentrations at the inlet to the converter.

It was observed:

1. Having $\text{O}_2 = 1.2\%$ concentration at the inlet to the catalytic converter – in the case of nitrogen oxides conversion Pt/cardierite type catalysts have a narrow functional temperature interval $200^\circ\text{C} - 250^\circ\text{C}$ where the maximum conversion of 95% is reached (Fig. 9, a). While $\text{CuO}/\gamma\text{-Al}_2\text{O}_3$ type catalysts are inactive at such conditions. In the case of carbon monoxide conversion Pt/cardierite type

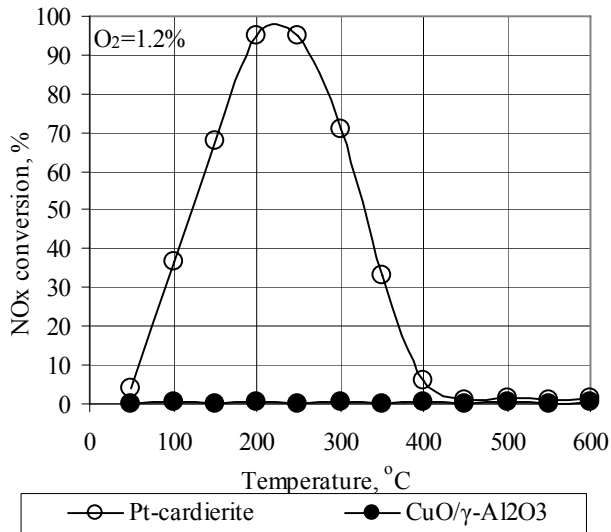

a

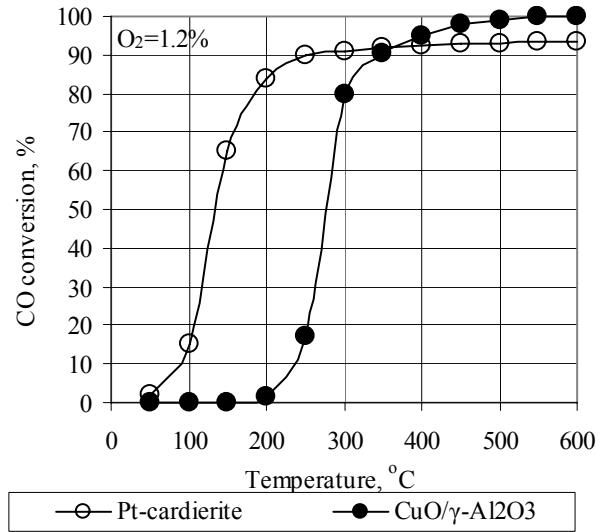

b

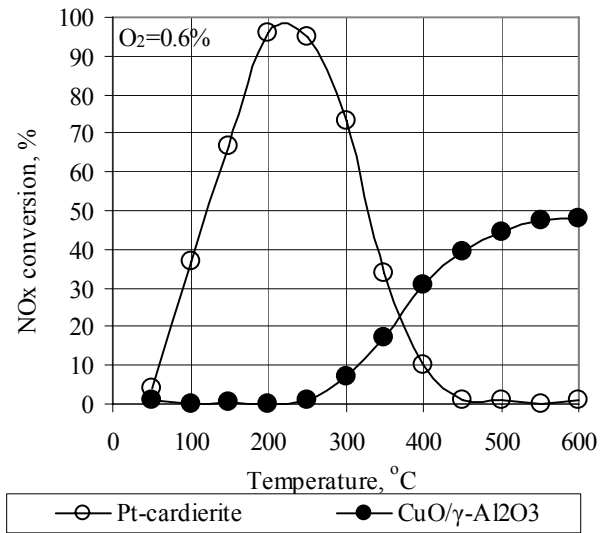

c

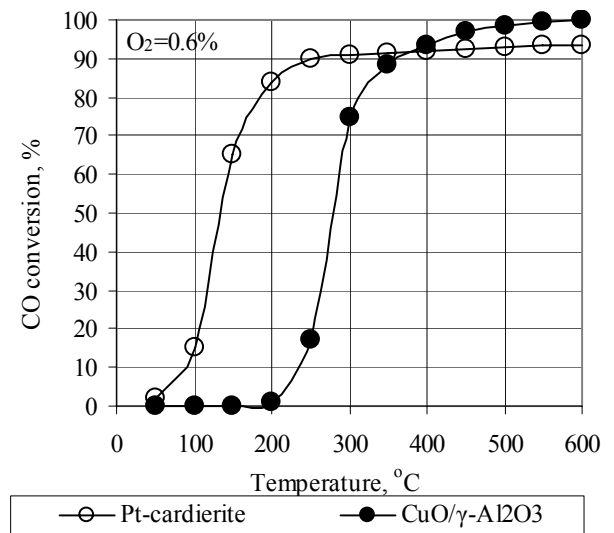

d

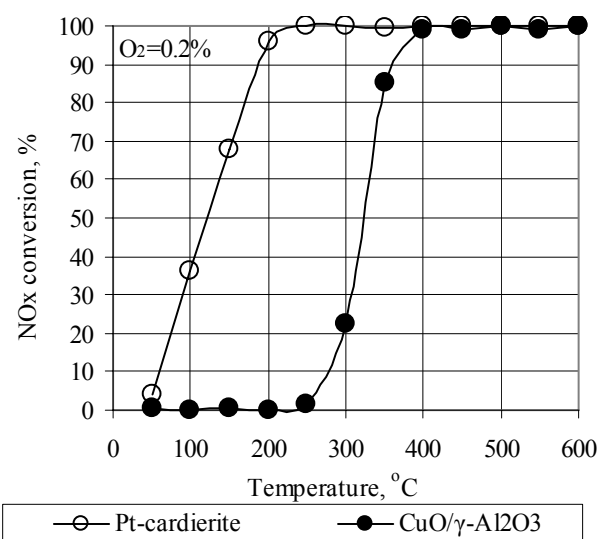

e

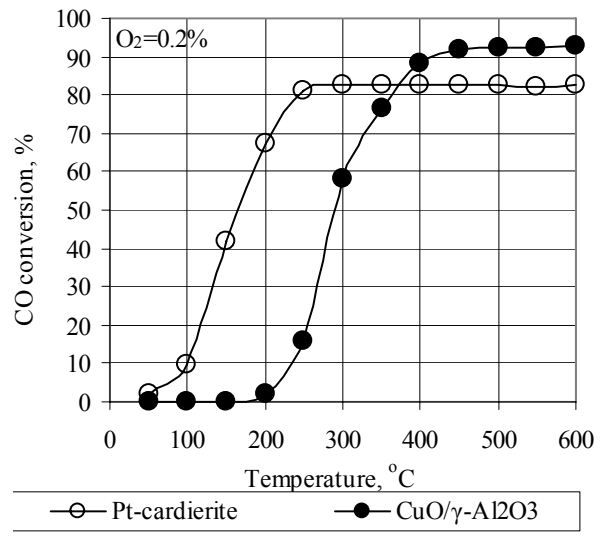

f

Fig. 9 NO_x and CO conversion dependency on heating temperature (point T 11) of catalysts monoliths

catalysts start to function earlier at lower temperatures but reach just 92% CO. While CuO/ γ -Al₂O₃ type catalysts reach 100% conversion (Fig. 9, b).

2. Having O₂ = 0.6% concentration at the inlet to the catalytic converter in the case of nitrogen oxides conversion Pt/cordierite type catalysts are functioning similarly as when O₂ = 1.2% (Fig. 9, c), T₅₀ reaches at 320°C and ends to operate at the temperature of 450°C. While CuO/ γ -Al₂O₃ type catalysts start to operate later at the temperature of 250°C, but operate at higher temperatures reaching the conversion of 48% at temperatures of 550°C – 600°C. In the case of carbon monoxide conversion both catalysts operate in the same way as under the conditions of O₂ = 1.2% (Fig. 9, d).

3. Having O₂ = 0.2% concentration at the inlet to the catalytic converter – in the case of nitrogen oxides conversion Pt/cordierite type catalysts function similarly as CuO/ γ -Al₂O₃, reach 100% conversion but start to operate earlier at lower temperatures (Fig. 9, e). In the case of carbon monoxide conversion both catalysts operate similarly as under the conditions of O₂ = 0.6%. Still Pt/cordierite type catalyst reaches a lower conversion of 82%, while CuO/ γ -Al₂O₃ type catalyst possess a higher conversion of 92% (Fig. 9, f).

4. Conclusions

1. The catalytic coating CuO/ γ -Al₂O₃ was obtained on the steel plates without the formation of the under layer at the temperature of 250°C, using the method of the activated thermo-chemical condensate deposition (AT-CCD). The adhesion of CuO/ γ -Al₂O₃ coatings, processed at the temperature of 650°C, reaches 28 N. The coating is steady in 20% solution of HCl and HNO₃ (relation 3:1) acids and is completely decomposed just after 26 hours.

2. CuO/ γ -Al₂O₃ coating at the temperature of 650°C contains two oxide phases: γ -Al₂O₃ and CuO where crystallite dimensions reach 7 nm and 21 nm respectively.

3. Reducing the concentration of oxygen at the inlet to the catalytic converter from 1.2 to 0.2%, the conversion of nitrogen oxides apparently increases. With the concentration of oxygen when O₂ = 0.6% Pt/cordierite type catalysts operate only at lower temperatures, while CuO/ γ -Al₂O₃ type catalysts operate only at higher temperatures. When O₂ = 0.2% both catalysts reach the conversion of 100%.

4. Increasing the amount of oxygen at the inlet to the catalytic converter from 0.2 to 1.2%, the conversion of carbon monoxide improves. Pt/cordierite type catalyst starts to operate at lower temperatures (50% conversion is obtained at the temperature of 160°C), CuO/ γ -Al₂O₃ type catalyst reaches 50% conversion at a higher temperature - 280°C. In case of CO conversion, having oxygen concentrations 0.6 and 1.2% at the inlet to catalytic reactor, Pt/cordierite type catalyst reaches 92%, while CuO/ γ -Al₂O₃ type catalyst maximum available – 100% conversion.

5. The reverse NO_x and CO conversion character shows that CuO/ γ -Al₂O₃ type catalysts could be used in 2 stage catalytic flue treatment – the first stage at low oxygen concentration NO_x decreasing process, the second

stage at increased oxygen concentrations CO oxidation process to CO₂.

References

1. **Paul, P.P., Heimrich, M.J., Miller, M.A.** Lean-NO_x reduction catalysis by metal-complex impregnated molecular sieves- effect of ligands and metals.- *Catalysis Today*, 1998, 42, p.61-71.
2. **Martin, L., Arranz, J.L., Prieto, O., Trujillano, R., Holgado, M.J., Galan, M.A., Rives, V.** Simulation three-way catalyst ageing analysis of two conventional catalyst.-*Applied Catalysis B: Environmental*, 2003, 44, p.41-52.
3. Directive 2001/80/EC of the European Parliament and of the Council. On the limitation of emissions of certain pollutants into the air from large combustion plants. - *Official Journal of the European Communities* of 23 October 2001. – L 309/(1-21).
4. **Chan, S.H., Hoang, D.L.** Heat transfer and chemical reactions in exhaust system of a cold-start engine.-*Int. J. of Heat and Mass Transfer*, 1999, 42, p.4165-4183.
5. **Pisarello, M.L., Milt, V., Peralta, M.A., Querini, C.A., Miró, E.E.** Simultaneous removal of soot and nitrogen oxides from diesel engine exhausts.-*Catalysis Today*, 2002, 75, p.465-470.
6. **Blanco, J., Avila, P., Suárez, S., Yates, M., Martín, J.A., Marzo, L., Knapp, C.** CuO/NiO monolithic catalysts for NO_x removal from nitric acid plant flue gas.- *Chemical Engineering Journal*, 2004, 97, p. 1-9.
7. **Babilius, K., Babilius, A.** Research of coatings obtained in the activated thermo-chemical condensate deposition method, Al-O system. -*Materials Science (Medžiagotyra)*, 2006, 2 (8), p.114-119.
8. **Jirat, J., Kubicek, M., Marek, M.** Mathematical modelling of catalytic monolithic reactors with storage of reaction components on the catalyst.-*Surface Catalysis Today*, 1999, 53, p.583-596.
9. **Ulrich, G.A., Bernd, S.** Engines and exhaust after treatment systems for future automotive.-*Applications Solid State Ionics*, 2006, 177, p.2291-2296.
10. **Babilius, K.** Tribological properties of titanium nitride coatings formed in arc discharge. -*Powder Technology In The Baltic States. Proceedings of the powder Baltic technology symposium.* -Kaunas, 1993, p.57-63 (in Russian).
11. JSPDS Cards – International Center for Diffraction Data. 12 Campus Boulevard Newtown Square, PA 19073-3273, USA.
12. **Cheary, R.W., Coelho, A.A.** Programs XFIT and FOURYA, deposited in CCP14 Powder Diffraction Library, Engineering and Physical Sciences Research Council, Daresbury Laboratory, Warrington, England, 1996 (<http://www.ccp14.ac.uk/tutorial/xfit-95/xfit.htm>)

A. Babilius, K. Babilius, R. Melkūnas, K. Buinevičius

KATALIZATORIŲ TESTAVIMO STENDAS, $\text{CuO}/\gamma - \text{Al}_2\text{O}_3$ DANGŲ TYRIMAI

R e z i u m ė

Straipsnyje aprašomi aktyvintu terminiu-cheminiu kondensato nusodinimo metodu gautų katalizinės paskirties $\text{CuO}/\gamma - \text{Al}_2\text{O}_3$ dangų tyrimai. Nagrinėta:

- dangos adhezija, atsparumas rūgštims, fazinė ir cheminė sudėtis, kristalitų dydis, morfologija;
- sukurto katalizatorių bandymo stendo, skirto katalizinių blokų anglies monoksido ir azoto oksidų konversijai įvertinti, techniniai sprendimai, pagrindiniai parametrai;
- katalizinė CO ir NO_x konversija, lyginant dviejų tipų katalizinius blokus: $\text{CuO}/\gamma - \text{Al}_2\text{O}_3$ (ant metalinio padėklo, termiškai apdorotą esant 650°C) ir monolitinis Pt / $\text{Mg}_2\text{Al}_4\text{Si}_5\text{O}_{18}$ (Pt/ kardieritas, klasikinį keraminį TWC katalizatorių).

Iš gautų rezultatų galima spręsti, kad katalizinės paskirties dangų $\text{CuO}/\gamma - \text{Al}_2\text{O}_3$ tipo katalizatoriaus užsidegimo temperatūra, visais nagrinėtais atvejais yra aukštesnė negu Pt/ kardieritas tipo katalizatoriaus. $\text{CuO}/\gamma - \text{Al}_2\text{O}_3$ tipo katalizatorius, kaip ir Pt/ kardieritas tipo, taip pat gerai veikia NO_x konversijos atveju, esant mažam deguonies kiekiui (0.2%). CO konversijos atveju, esant diskretiškam deguonies kiekiui katalizinio reaktoriaus įėjime 0.6% ir 1.2%, Pt/ kardieritas tipo katalizatorius pasiekia 92%, o $\text{CuO}/\gamma - \text{Al}_2\text{O}_3$ tipo katalizatorius, - maksimaliai galima-100% konversiją.

A. Babilius, K. Babilius, R. Melkūnas, K. Buinevičius

FACILITY FOR CATALYSTS TESTING, RESEARCH OF $\text{CuO}/\gamma - \text{Al}_2\text{O}_3$ COATINGS

S u m m a r y

The article presents investigations of catalytic $\text{CuO}/\gamma - \text{Al}_2\text{O}_3$ coatings obtained by activated thermochemical condensate deposition method. It was researched:

- coating adhesion, resistance to acids, phase and chemical composition, crystal dimensions, morphology;
- technical solutions and main parameters of the test facility for catalysts testing and determining conversion of carbon monoxides and nitrogen oxides;
- catalytic CO and NO_x conversion, in comparison of two type catalytic monoliths: $\text{CuO}/\gamma - \text{Al}_2\text{O}_3$ (on the steel plates, thermally processed at 650°C) and

Pt/ $\text{Mg}_2\text{Al}_4\text{Si}_5\text{O}_{18}$ (Pt/cardierite, classical ceramic TWC catalyst).

The obtained results show that $\text{CuO}/\gamma - \text{Al}_2\text{O}_3$ type catalyst, has higher inflammation temperature in all cases in comparison with Pt/cardierite type catalyst. $\text{CuO}/\gamma - \text{Al}_2\text{O}_3$ type catalyst the same as Pt/cardierite type catalyst operates well in case of NO_x conversion, if low oxygen amount is present in flue gas. In case of CO conversion, having oxygen concentrations 0.6% and 1.2% at the inlet to catalytic reactor, Pt/cardierite type catalyst reaches 92%, while $\text{CuO}/\gamma - \text{Al}_2\text{O}_3$ type catalyst maximum available – 100% conversion.

А. Бабилюс, К. Бабилюс, Р. Мелкунас, К. Буинявичюс

СТЕНД ДЛЯ ТЕСТИРОВАНИЯ КАТАЛИЗАТОРОВ, ИССЛЕДОВАНИЯ $\text{CuO}/\gamma - \text{Al}_2\text{O}_3$ ПОКРЫТИЙ

Р е з ю м е

В статье представлены исследования каталитических $\text{CuO}/\gamma - \text{Al}_2\text{O}_3$ покрытий, полученных методом активированного термохимического осаждения конденсата. Исследовано:

- адгезия, стойкость к кислотам, фазовый и химический состав, величина кристаллитов и морфология покрытий;
- технические решения и основные параметры созданного стенда каталитических испытаний для определения конверсии монооксида углерода и окислов азота в каталитических конвертерах;
- конверсия CO и NO_x , при сравнении каталитических блоков двух типов: $\text{CuO}/\gamma - \text{Al}_2\text{O}_3$ (на металлической подложке, термическая обработка при температуре 650°C) и монолитный Pt / $\text{Mg}_2\text{Al}_4\text{Si}_5\text{O}_{18}$ (Pt/cardierite, классический, керамический катализатор типа TWC).

По полученным результатам можно судить, что катализатор типа $\text{CuO}/\gamma - \text{Al}_2\text{O}_3$ в исследованных случаях имеет более высокую температуру зажигания по сравнению с катализатором типа Pt/cardierite. Катализатор $\text{CuO}/\gamma - \text{Al}_2\text{O}_3$ типа, как и типа Pt/ cardierite, так же хорошо работает в случае конверсии NO_x , при малом количестве кислорода (0.2%). В случае конверсии CO при дискретном исследовании (количество кислорода 0.6% и 1.2% на входе в каталитический конвертер), катализатор типа Pt/ cardierite достигает конверсию 92%, в то время катализатор типа $\text{CuO}/\gamma - \text{Al}_2\text{O}_3$ - максимально возможную конверсию - 100%.

Received March 15, 2008