

Creation and investigation of nanopositioning systems

L. Limanauskas*, K. Nemčiauskas**, V. Lendraitis***, V. Mizarienė****

*Kaunas University of Technology, Studentu st. 65, 51369 Kaunas, Lithuania, E-mail: leopoldas.limanauskas@ktu.lt

**Kaunas University of Technology, Studentu st. 65, 51369 Kaunas, Lithuania, E-mail: kestutis.nemciauskas@ktu.lt

***Kaunas University of Technology, Studentu st. 65, 51369 Kaunas, Lithuania, E-mail: vitas_1@hotmail.com

****Kaunas University of Technology, Studentu st. 65, 51369 Kaunas, Lithuania, E-mail: vimiz@ktu.lt

1. Introduction

The growing requirements in microelectronics, optics, and biology set new requirements for instrumental equipment in engineering as well as in metrology. New technologies such as nanoimprinting, scanning microscopy, scanning instruments for surface research, nanolithography, automatic identification systems and micro-machining, request for ultra-precision positioning instruments, which would ensure the nanometric accuracy of positioning [1].

Nanopositioning system is much more than just displacement sensor, interpolation circuit or medium step of motor. In nanoworld the leading role belongs to factors which are not important in macro or micro world. Such powers are friction, deformation, hysteresis, and to obtain the repetitive movement in nanometric movement distances becomes a big problem, which is impossible to solve in real world. The old knowledge which was sufficient for the development of micro positioning systems is not enough. This becomes obvious according to the data that the leaders of nanopositioning systems are new companies which started their work about a decade ago. While analyzing the tendencies in nanopositioning system market an obvious tendency in five year period is seen – the number of new small companies, which offer nanopositioning and nanometrology instruments with new methods and principles, is rapidly growing [1, 2].

The main rule of nanopositioning says that there must be no friction pairs in nanopositioning systems. That means that all devices which have roll or slip bearings cannot be the constituent of nanopositioning system. But air slip bearings and flexure guide may be used in nanopositioning as flexure guide has no friction pairs, their work is based on elastic deformation of productive flexure of solid body.

Air bag type bearings are ideal guide when large positioning distances are necessary, but they are massive, inert and expensive. Lately with the help of powdery metallurgy materials air bag type systems may be developed of complicated construction and form, small size, but they are acceptable just in special instruments because of air supply systems. Besides, air bags cannot be applied where vacuum is needed.

In turn, flexure guide cannot ensure a large distance of positioning. It is unlikely that positioning distances ≥ 100 mm and precision of nanometric positioning is a technological necessity but a number of laboratories try to solve this problem [3, 4].

Correctly designed flexure guide is a rigid mechanical structure, which ensure high mutual axes slope, has no friction pairs and can be designed as system with

many degrees of freedom. Their production is technological and exploitation is simple. These characteristics, according to the analysis of nanopositioning instrument market, make the nanopositioning and scanning systems the best choice in the field of nanopositioning instruments. Nanopositioning flexure guide types, developed in foreign companies and Research Center for Microsystems and Nanotechnology, Kaunas University of Technology, are presented in Fig. 1.



Fig. 1 General picture of nanoscanner

Designing positioning system it is necessary to realize if preference is given to nanopositioning accuracy or submicron precision is enough.

Motors without friction pairs are straight-line engines, electromagnetic voice coil and piezoactuators [5].

The first two types fit to large shift/displacement, but they possess such shortcomings as strong magnetic fields that appear in the environment of positioning instrument, a large quantity of heat, large movement inertia and low rigidity.

2. Mathematical model of nanoscanner

Nanoscanner is composed of two one flat flexure platens for x, y movement. They have separate four duplicate flexure hinges symmetrically stated. Consequently mathematical model is driven analytically for one flexure hinge (Fig. 2).

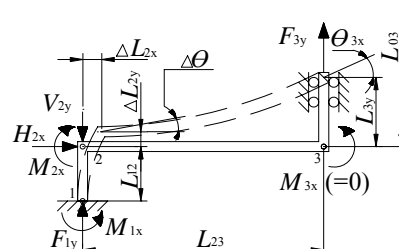

Fig. 2 Mathematical model of nanoscanner

The flexure hinge will be analyzed here by means of a rigid link, and the direct-bending stiffness will be evaluated. In order to solve a plate, problem of flexure hinge is discussed as well as the influence of boundary conditions on stiffness of the plate in bending.

Conditionally we admit, that 2-3 point 2 of the plates (Fig. 2) is rigid fixed in first stage of analysis.

Find a spring constant corresponding to the elastic interaction between the force F_{3y} and the resulting deflection L_{3y} for the plate by using Castigliano's displacement theorem [6]. The stiffness of the plate becomes

$$K_{L_{23}, F_{3y}-L_{3y}} = \frac{12EI_y}{L_{23}^3} \quad (1)$$

Stiffness basics

$$\Delta L_{23} = \frac{\partial L}{\partial H_{2x}} \quad (2)$$

Since the system of Fig. 2 is three-times indeterminate, the reactions H_{2x} , V_{2y} and M_{2x} need to be determined first, using the corresponding boundary conditions:

$$\begin{cases} \Delta L_{2x} = 0 \\ \Delta L_{2y} = 0 \\ \Delta \Theta_{2x} = 0 \end{cases} \quad (3)$$

which can be expressed as

$$\begin{cases} \Delta L_{2x} = \frac{\partial L}{\partial H_{2x}} = \\ = \frac{1}{EI_y} \cdot \int_0^{L_{23}} \left[M_{bx}^{(2)} \frac{\partial M_{bx}^{(2)}}{\partial H_{2x}} + M_{bx}^{(3)} \frac{\partial M_{bx}^{(3)}}{\partial H_{2x}} \right] dx \\ \Delta L_{2y} = \frac{\partial L}{\partial V_{2y}} = \\ = \frac{1}{EI_y} \cdot \int_0^{L_{23}} \left[M_{bx}^{(2)} \frac{\partial M_{bx}^{(2)}}{\partial V_{2y}} + M_{bx}^{(3)} \frac{\partial M_{bx}^{(3)}}{\partial V_{2y}} \right] dx \\ \Delta \Theta_{2x} = \frac{\partial L}{\partial M_{2x}} = \\ = \frac{1}{EI_y} \cdot \int_0^{L_{23}} \left[M_{bx}^{(2)} \frac{\partial M_{bx}^{(2)}}{\partial M_{2x}} + M_{bx}^{(3)} \frac{\partial M_{bx}^{(3)}}{\partial M_{2x}} \right] dx \end{cases} \quad (4)$$

The bending moment is

$$\begin{cases} M_{bx}^{(2)} = -M_{2x} + V_{2y} x \\ M_{bx}^{(3)} = -M_{2x} + V_{2y}(L_{23} - x) + H_{2x}L_{03} + F_{3y} x \end{cases} \quad (5)$$

where L_{03} is the length between two parallel flexure hinges of plate. The unknown reactions are

$$\begin{cases} V_{2y} = F_{3y} / 2 \\ H_{2x} = -F_{3y}L_{23} / (2L_{03}) \\ M_{2x} = F_{3y}L_{23} / 4 \end{cases} \quad (6)$$

The displacement to direction F_{3y} of point 3 can now be found by means of Eq. (2), (4), (5) and (6) which give the stiffness about the y direction as:

$$K = 24EI_y / L_{23}^3 \quad (7)$$

Eq. (7) shows that the stiffness of the two-plate structure can be found by summing up the stiffness given in Eq. (1), and therefore it can be considered that the two plates act as two springs in parallel of flexure platen.

In addition, the slope at point 3 (Fig. 2) is calculated here. This slope can be found in a similar way, by following the two-step procedure outlined previously. The new reactions have to be determined by applying Eq. (3) and (4). The only difference is that M_{3x} dummy moment [6] has to be added in the bending moment of the second Eq. (5). It can be shown that the two reactions of Eq. (6) are the same, whereas the bending moment reaction becomes

$$M_{2x} = M_{3x} / L_{23} - F_{3y}L_{23} / (2L_{03}) \quad (8)$$

With this addition, the slope at point 3 is calculated as

$$\Delta L_{23} = \frac{\partial L}{\partial M_{3x}} \quad (9)$$

and its value is zero since the dummy moment is also zero. This result confirms the physical intuition that the system should deform under the action of the force F_{3y} such that the rigid platen translates in y direction on the flat.

The situation will be analyzed here where plate 1, 2 of flexure hinge the point 2 is free, as is in real mathematical model, in second stage, with calculated parameters H_{2x} , V_{2y} and M_{2x} of plate 2, 3, but $M_{2x} \neq 0$. Solution is alike as stated above. A result of plates 1, 2 and 2, 3 in total is intention of this mathematical model.

3. The investigation methodology and equipment

Original system of atomic force microscope (AFM) positioning in „X-0-Y“ plane is developed; it enables to lay out the object in the point of measurement sensor in nanometric precision. The accent of AFM nanomanipulator because of flexure hinge is a compact monolithic construction (Fig. 1).

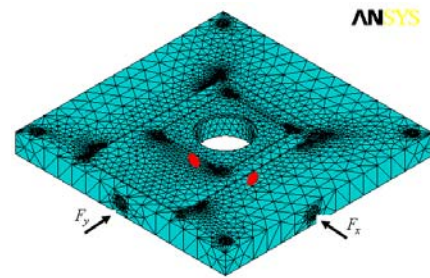

Fig. 3 Numerical experiment model of monolithic two coordinate nanoscanner: F_x , F_y – directions of piezoceramic transducer effect on plane „X-0-Y“

Using the finite element method, the numerical modeling of investigated construction investigated is per-

formed, where the structure is separated into the simple geometry finite elements and their type depends on the task solved. The ANSYS software package was selected for the analysis of nanomanipulator. Solid 45 type finite elements were chosen to model this type of construction. These elements are usually used to model solid plane structures of various thickness and elastic material constructions [7] (Fig. 3).

Using finite element method the amplitude - frequency characteristics are calculated. The analysis of the frequency results is presented in Fig. 4.

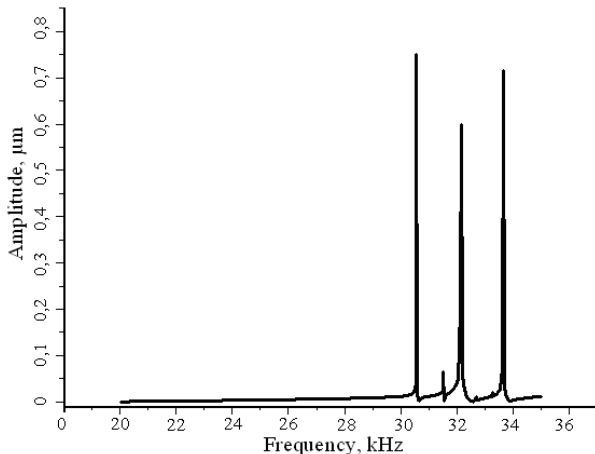

Fig. 4 Theoretical amplitude - frequency characteristics of nanoscanner

4. Experimental results

Scanning the objects with nanometric precision, the generated scanning signal is potentially the source of mechanical resonance in AFM system.

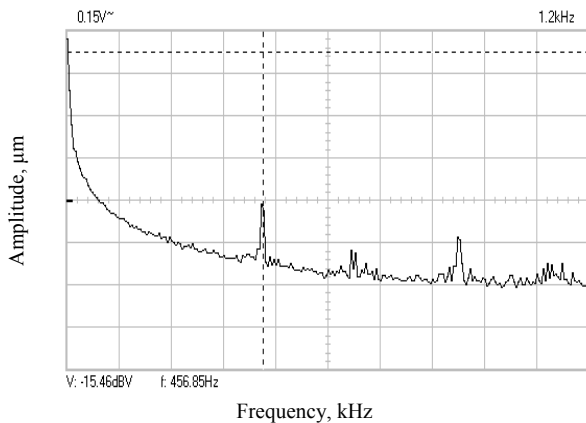

Fig. 5 The frequency of mechanical resonance in AFM system

Using the scanning frequency of 1Hz (it is the most usual mode in surface topographic research) the frequency of mechanical resonance in AFM system is expected at 456 Hz frequency (Fig. 5).

In computerized spectral characteristics research stand (Fig. 6) nanoscanner's free oscillation frequency was evaluated, in the range of 100 Hz-100 kHz by exciting nanoscanner in X, Y coordinates by piezoceramic converters with fixed amplitude signal (10 V) and measuring object's table (Fig. 3) response (oscillation acceleration) in

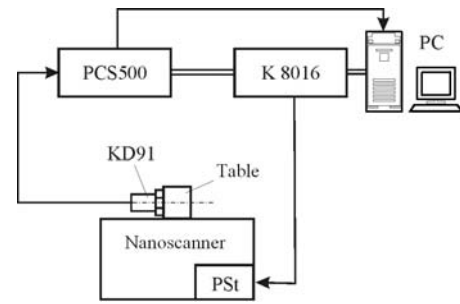
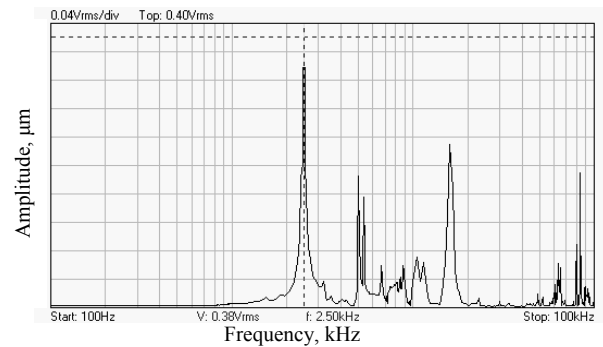

Fig. 6 Block scheme of nanoscanner spectral characteristic evaluation stand: PC – personal computer; K 8016 – „Velleman Instruments“ function generator; PSt – nanoscanner particular coordinate piezoceramic actuator PSt 150/7x7/20; KD91 – frequency transducer; PCS500 – „Velleman Instruments“ oscillograph

the two coordinates. The measurement results are presented in Fig. 7.

During the investigation stated a minimal nanoscanner's free oscillation frequency 2.15 kHz (Fig. 7, b) is almost 5 times higher than the frequency of forced oscillation therefore the influence of possible scanning process frequency over the picture quality of researched object is negligible small.



a

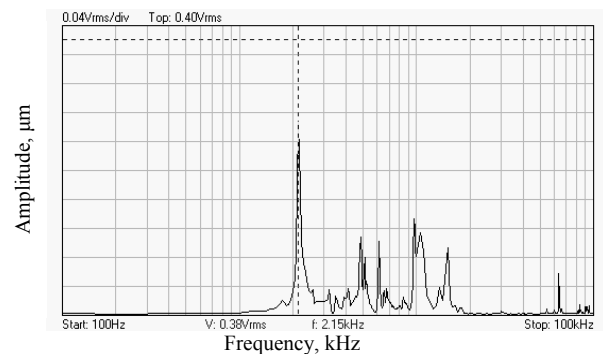

b

Fig. 7 Nanoscanner amplitude – frequency characteristics: a – „X“ coordinate direction ($f_{rez}=2.50$ kHz); b – „Y“ coordinate direction ($f_{rez}=2.15$ kHz)

The nanomanipulator of such type, which is designed for fast XY positioning with nanometrical precision, may be successfully used for biological AFM and near-field scanning optical microscopy.

5. Conclusions

1. Mathematical model of nanoscanner is made.
2. The work of nanoscanner in the dynamic mode was modeled applying finite element method.
3. Positioning with nanometric reiteration level is possible in the systems without surface friction pairs.
4. The precise compact construction of nanoscanner was developed.
5. Applying experimental stand, integrated in lateral force microscope (LFM) system, the evaluation of nanoscanner response is obtained.
6. Positive investigation's results of nanoscanner allow extend facilities of commercial LFM in a field of nanolithography.

References

1. **Szita, N., Sutter, R., Dual, J. and Buser, R.A.** A micropipettor with integrated sensors. -Sensors and Actuators A, 2001, v.89, No.1-2, p.112-118.
2. **Dai, G., Pohlenz, F., Danzebrink, H.-U., Xu, M., Hasche, K., Wilkening, G.** A metrological large range scanning probe microscope. -Rev. Sci. Instrument. 2004, No75(4), p.962-969.
3. **Bansevičius, R., Fallahi, B., Toločka, R.T., Varnavičius, V.** Smart Underactuated Manipulator: Design and Dynamics Simulation. -Mechanika. -Kaunas: Technologija, 2002, Nr.6(38), p.63-66.
4. **Ažubalis, M., Bansevičius, R., Toločka, R.T.** New approach for the design of tactile devices. -Mechanika. -Kaunas: Technologija, 2003, Nr.6(44), p.50-54.
5. http://www.physikinstrumente.de/pdf/extra/2004_PICatLowRes_www.pdf
6. **Lobontiu, N., Garcia, F.** Mechanics of Microelectromechanical Systems. -Kluwer Academic Publishers, Springer Science +Business Media, Inc., Boston. 2005. -486p.
7. ANSYS, Revision 10.0, Swanson Analysis Systems Inc., Houston, USA. 2005.-586p.

L. Limanauskas, K. Nemčiauskas, V. Lendraitis, V. Mizarienė

NANOPOZICIONAVIMO SISTEMŲ MODELIAVIMAS IR TYRIMAS

Reziumė

Straipsnyje pateiktas sukurto nanoskennerio matematinis modelis, statikos ir dinamikos tikslumo tyrimo rezultatai, gauti eksperimentinį standą integravus į skersinės jėgos mikroskopą (SJM).

Nanoskennerio dinamika išreikšta matematiškai, naudojant paskirstytųjų parametrų modelį baigtinių ele-

mentų metodu. Nustatyti teoriniai ir eksperimentiniai nanoskennerio staliuko savieji rezonansiniai dažniai. Eksperimentiškai ištirtos tikslumo charakteristikos be paklaidų kompensavimo bloko ir su juo.

Tyrimo rezultatai naudotini atliekant nanolitografinius tyrimus SJM galimybės praplėsti.

L. Limanauskas, K. Nemčiauskas, V. Lendraitis, V. Mizarienė

CREATION AND INVESTIGATION OF NANOPOSITIONING SYSTEMS

S u m m a r y

In the article the mathematical model of the developed nanoscanner is presented. The research results of static and dynamic precision integrating the experimental stand into LFM system are presented, too.

Nanoscanner dynamics is expressed mathematically applying the Finite elements method. Theoretical and experimental resonant frequency of nanoscanner table is measured. Precision characteristics with error compensation block and without it are investigated experimentally.

The investigation results are to be used in the field of nanolithography in order to enlarge the possibilities of transverse force microscope.

Л. Лиманаускас, К. Немчаускас, В. Лендрайтис, В. Мизарене

СОЗДАНИЕ И ИССЛЕДОВАНИЕ НАНОПОЗИЦИОННЫХ СИСТЕМ

Р е з ю м е

В статье представлены математическая модель, результаты исследования статистической и динамической точности созданного наносканера с интегрированным экспериментальным стендом в микроскоп поперечной силы.

Динамика наносканера выражена в математической форме, используя модель распределенных параметров, методом конечных элементов. Установлены теоретические и экспериментальные собственные резонансные частоты столика наносканера. Экспериментально исследованы характеристики точности перемещения столика без блока компенсации ошибок и с ним.

Результаты исследования рекомендуется использовать в области нанолитографических исследований совместно с микроскопом поперечной силы для расширения его возможностей.

Received March 06, 2008