

Pulse Sensor of Physiological Parameter Monitoring System

J. Daunoras

*Department of Control Technology, Kaunas University of Technology,
Studentų st. 48, LT-51368 Kaunas, Lithuania, phone: +370 37 300251; e-mail: jonas.daunoras@ktu.lt*

R. Lukočius, J. A. Virbalis

*Department of Theoretical Electric Engineering, Kaunas University of Technology,
Studentų st. 48, LT-51368 Kaunas, Lithuania, phone: +370 37 300267; e-mail: robertas.lukocius@ktu.lt
arvydas.virbalis@ktu.lt*

Introduction

Application of computer systems has been growing greatly in medicine over the last few decades. There are developed physiological parameter monitoring and clinical decision support systems, which help to take clinical decisions for medical personnel [1].

Possibilities of application of system for human physiological parameter monitoring are growing in other application areas. The reason is minimization of physical space and power consumption of electronic components and novel inventions in material sciences. The manufacturers of electronic components offer low power consumption components integrated into a small packages. So, physiological parameter monitoring systems could be designed as mobile systems. There are some possibilities of application of conductive threads for electrocardiogram electrodes and for respiration sensor design [2]. Better comfort characteristics of the human physiological parameter monitoring system could be reached. It gives possibility to integrate the system into the clothes as well. Application of the system could be extended from medicine to industrial safety, sports and other areas.

Pulse is one of the key of physiological parameters for human state evaluation [3]. The goal of work was to design pulse sensor, which meets main requirements for physiological parameter monitoring system sensors: robustness to motion artifacts, comfort and low power consumption. We will take into account in sensor design that monitored people could intensively move (walk, climb, flex).

Structural scheme of the sensor

The main heart rate sensor principles are:

- Heart rate detection from electrocardiogram;
- Photoplethysmography;
- Inductance plethysmography;
- Doppler effect;

- Phonocardiography;
- Shock sensors.

The method of heart rate detection from electrocardiogram was chosen because of its robustness to motion artifacts, low power consumption and possibility to analyze electrocardiogram of monitored man [4].

Signal gathering, amplification, analog processing and analog to digital conversion is handled in a mobile system part, digital processing and visualization – in a personal computer. These two system parts are connected by wireless connection. Structure of the pulse measurement system and arrangement of functions is presented in Fig. 1.

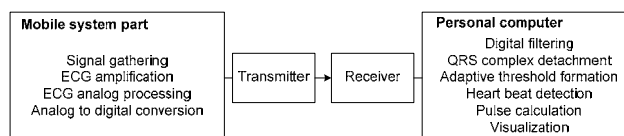

Fig. 1. Structure of pulse meter

Scheme of signal amplification and analog processing

Specifics of electrocardiogram (ECG) measurement is small amplitude (about 1mV) signal extraction from much higher amplitude noises. The main noise sources are: potential of electrode polarization, noises generated by changes of electrode to skin contact, 50 Hz line interference, high frequency noises, generated from other electronic devices, noises generated by muscles.

Two stage single supply scheme with instrumentation amplifier was applied (Fig. 2). Single supply Texas Instruments instrumentation amplifier INA326 has good common mode voltage (50 Hz and electrode polarization, which could reach 500 mV), rejection characteristics – CMR>94 dB. Electrode polarization potential has differential part as well, which could also reach few hundreds of mV, while electrocardiogram signal is about 1 mV amplitude peak to peak. To avoid saturation logic was applied:

- Chosen low first stage gain (instrumentation amplifier gain=5);
- Low pass filter (integrator A2) was applied in feedback for direct signal component decrement;
- Operational amplifier A1 amplifies alternating signal (gain=100) and acts as a lowpass filter (3 dB cutoff frequency 100 Hz).

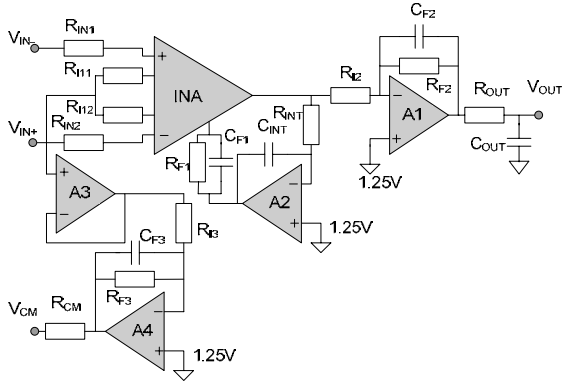

Fig. 2. Scheme of electrocardiogram signal amplification and analog processing

Electrocardiogram signal bandwidth is 0.05 to 100 Hz. Integrator 3 dB cutoff frequency is:

$$f = \frac{1}{2\pi R_{INT} C_{INT}} \cong 0.05 \text{ Hz} . \quad (1)$$

This cutoff frequency could be increased, if electrocardiogram is not signal of interest and pulse is. Filter with 3 dB cutoff frequency at 8 Hz showed much better reliability characteristics of sensor, because of increased robustness to motion artifacts. But the electrocardiogram signal became unacceptable for analysis because of most P, T and other wave suppression.

Operational amplifiers A3 and A4 were used for additional 50 Hz noise suppression.

Analog to digital conversion and data transmission

Low power microcontroller MSP430F169 is used for analog to digital conversion and for control of data transmission. The microcontroller supports five sleep modes. Processor of microcontroller is off and it is waked up just by interrupts. So, power consumption of microcontroller is reduced. Analog to digital conversion is implemented by 12 bit successive approximation register (SAR) analog to digital converter integrated into the microcontroller. Sample frequency is 512 samples per second. Voltage reference integrated in the microcontroller is used for pedestal voltage generation for a single supply measurement and analog processing scheme.

Wireless data transmission system was chosen according to parameters of the system: power consumption, operation range, speed, and compatibility with other devices, which could be used in a future for system expanding. Comparison of common, short range data transfer wireless systems is presented in Table 1.

Wireless data transfer systems, operating on IEEE 802.11 (Wi - Fi) standard has high data transfer rate, but high power consumption as well. Systems operating on the

basis of IEEE 802.15.4 (ZigBee) and IEEE 802.15.1 (Bluetooth) standards have much lower power consumption in comparison with IEEE 802.11, and speed is sufficient if such parameters as heart rate, respiration rate, movements are monitored. ZigBee standard was chosen. The reason was better operating range and power consumption characteristics.

Table 1. Comparison of common short range wireless systems

Application	ZigBee	Bluetooth	Wi - Fi
Monitoring and control	32000	7	32
Transfer rate (kb/s)	20 – 250	Above 1000	54000
Operation range (m)	100	10	100
Power consumption (TX mode)	25 – 45 mA	40 mA	Above 400mA
Power consumption (Sleep mode)	3-10 μ A	200 μ A	20 mA

Operation of XBee data transmission module is controlled by microcontroller MSP430F169 logic signals and USART module of microcontroller. Data is received by the same XBee module and is transferred by RS232 cable to the ComPort of personal computer.

Data processing

QRS complex emphasis and detection was used for heart beat detection and heart rate calculation. Relative power spectra of ECG, QRS complexes, P and T waves, motion artifact, and muscle noise are presented in Fig. 3 [5].

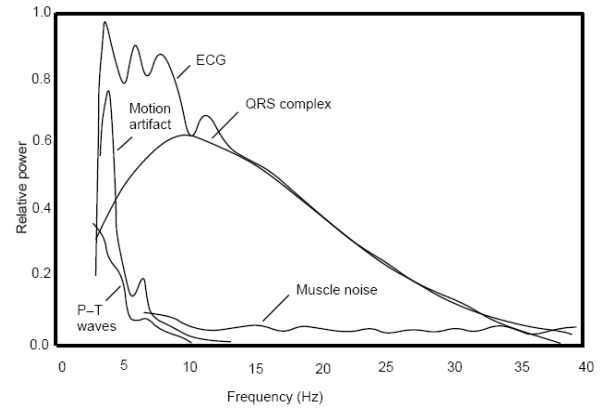

Fig. 3. Relative power spectra of ECG, QRS complex, P and T waves, motion artifacts and muscle noise

Scheme of digital signal processing used for QRS complex resolution is presented in Fig. 4.

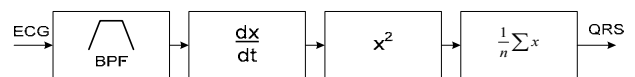

Fig. 4. Structure of algorithm for QRS resolution

where BPF – band pass filter with a corner frequencies 8 and 20 Hz; dx/dt – derivative; x^2 – square function; and $1/n \sum x$ – moving window integral.

Sensor application specific is heart rate monitoring in a daily life. So, robustness to human movement artifacts is

essential for the sensor. The main QRS complex energy is concentrated in a frequency range from 3 to 20 Hz, while main energy of noises generated by motion artifacts, by P and T waves are concentrated up to 5 Hz. So, sufficient signal suppression up to 5 Hz is essential. Eighth order infinite impulse response high pass filter which 3dB corner frequency is 8 Hz was designed for this goal. Second order cascade realization was used for filter implementation

$$H(z) = \frac{Y(z)}{X(z)} = \frac{G_1(z)}{X(z)} \cdot \frac{G_2(z)}{G_1(z)} \cdots \frac{Y(z)}{G_K(z)} =$$

$$= H_1 \cdot H_2 \cdots H_K = \prod_{i=1}^K H_i(z); \quad (2)$$

There each filter section is

$$H_i(z) = \frac{a_{0i} + a_{1i}z^{-1} + a_{2i}z^{-2}}{1 + b_{1i}z^{-1} + b_{2i}z^{-2}}. \quad (3)$$

Low pass eight order filter is used for 50 Hz, high frequency noise and noise generated from muscles, filtering. 3 dB cutoff frequency of the filter is 20 Hz.

14-th order derivative was used for further QRS emphasis. Transfer function of the derivative is

$$H(z) = a_0 + a_1 \cdot z^{-1} + a_2 \cdot z^{-2} + \dots + a_{13} \cdot z^{-13}. \quad (4)$$

Value squaring is next signal processing stage

$$h(nT) = [x(nT)]^2. \quad (5)$$

This is not linear signal amplification, where higher frequencies, which are mainly due to QRS complex, are emphasized [5].



Fig. 5. Electrocardiogram signal (above) and processed signal (below)

Many abnormal QRS complexes that have large amplitude and long duration might not be detected if output of the square block would be used. The improvement is made by applying moving window integral:

$$y(nT) = \frac{h(nT - (N-1)T) + h(nT - (N-2)T) + \dots + h(nT)}{N}, \quad (6)$$

where N – number of measurements involved into the mowing window integral. N is chosen according to

maximal duration of QRS – 150 ms. $N=76$ for 512 Hz sampling frequency.

Results of signal processing are presented in Fig. 5.

QRS complex detection and pulse calculation

Adaptive threshold (Fig. 6), used for QRS detection is composed of two parts: steep slope threshold – M , and beat expectation threshold – R [6].

First value of steep slope threshold is obtained from maximal 5 second value of the processed signal:

$$M_{(1)} = 0.6 \cdot \max(y). \quad (7)$$

QRS complex is detected if such condition is met:

$$Y_i \geq M + R. \quad (8)$$

Permission to detect next QRS complex is denied for 230 ms after each QRS complex is detected. Newest threshold buffer value is calculated in a period QRS – QRS +230 ms:

$$newM_5 = 0.6 \cdot \max(Y_i). \quad (9)$$

The estimated value can become quite high, if steep slope premature ventricular contraction or artifact appeared, so it has to be limited [6]:

$$newM_5 = 1.1 \cdot M_5, \quad (10)$$

$$\text{if } newM_5 > 1.5 \cdot M_5. \quad (11)$$

Steep slope threshold buffer is refreshed excluding oldest component and including newest:

$$M_5 = newM_5. \quad (12)$$

New steep slope threshold value is calculated:

$$M = \frac{1}{5} \sum_{i=1}^5 M_i. \quad (13)$$

M is linearly decreased in an interval 230 to 1200 ms after last QRS detection, reaching 60 % of its refreshed value at 1200ms. After 1200 ms M remains unchanged.

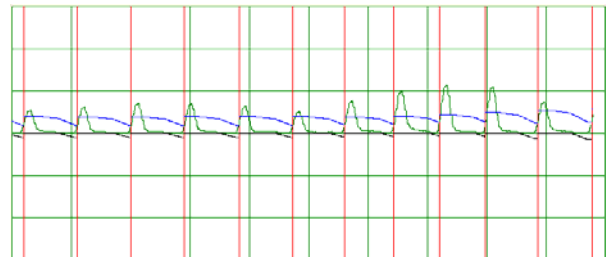

Fig. 6. Beat detection with adaptive thresholds

Beat expectation threshold – R is useful for detection of the beat with small amplitude which comes after normal amplitude beats. Fast amplitude decrease could appear in cases of electrode artifacts. Buffer of five $R - R$ time interval values is refreshed after new QRS detection. R_m is the mean value of the buffer. $R=0$ in the time interval QRS – QRS+2/3 R_m . R decreases 2 times faster then the steep slope threshold (M in time interval QRS+230 ms –

QRS+1200ms) does in the time interval QRS+2/3R_m – QRS+R_m. After time QRS+R_m R value becomes constant.

Pulse value is calculated:

$$P = \frac{60}{L} \sum_{k=n-L}^n \frac{1}{\tau_k}; \quad (14)$$

where P – pulse value; L – length of buffer of pulse values ($L=5$); $\tau_k = t_k - t_{k-1}$, where t_k and t_{k+1} – time when k – th and $k-1$ –th beats were detected.



Fig. 7. Pulse sensor

Possibilities of power consumption minimization

Sensor (Fig. 7) uses 45 mA current (supply voltage – 8V). Transceiver uses the main part of the current. Measurement circuit and microcontroller uses just about 8 mA. Such possibilities of power consumption minimization must be investigated:

- Reduction of the sample rate;
- Application of transceiver sleep modes;
- Implementation of digital signal processing, pulse detection and calculation in the microcontroller. Thus just pulse values or emergency signals could be transferred;
- Shutdown of measurement circuit between sample periods.

Conclusions

Pulse sensor hardware was designed and software was written. One lead of ECG is transferred to computer by wireless connection to personal computer. ECG data is processed, pulse is calculated and visualization is made in a personal computer.

There is a need for further research for sensor power consumption minimization.

References

1. Gargasas L., Vainoras A., Ruseckas R., Jurkonis V., Jurkonienė R., Korsakas S., Miškinis V. Fiziologinių procesų stebėsenos ir širdies nepakankamumo diagnostikos kompiuterizuotų sistemų kūrimas // Elektronika ir elektrotechnika. – 2005. – No.4(60). – P. 53 – 57.
2. Catrysse M., Ouers R., Hertleer C., Van Langenhove L., Van Egmond H., Mattys D. Towards the integration of textile sensors in a wireless monitoring suit // Sensors and actuators. – 2004. – No. A114. – P. 302–311.
3. Dosinas A., Vaitkūnas M., Daunoras J. Measurement of Human Physiological Parameters in the Systems of Active Closing and Wearable Technologies // Electronics and Electrical Engineering. – 2006. – No 7(71). – P. 77 – 82.
4. Lukočius R., Virbalis J. A., Vegys A. Optimization of physiological parameter monitoring systems applied in a daily activity // Proceedings of International Conference “Electrical and Control Technologies – 2006”. – P. 142 – 146.
5. Tompkins W. J. Biomedical Digital Signal Processing. – 2000.
6. Christov I. Real time electrocardiogram QRS detection using combined adaptive threshold // BioMedical Engineering OnLine – 2004.

Submitted for publication 2007 03 13

J. Daunoras, R. Lukočius, J. A. Virbalis. Pulse Sensor of Physiological Parameter Monitoring System // Electronics and Electrical Engineering. – Kaunas: Technologija, 2007. – No. 6(78). – P. 67–70.

The aim of the work was to design pulse sensor which could be applied in a daily human activity. The main pulse measurement principles are presented. Heart rate detection from electrocardiogram was chosen. The reason of this choice was robustness to motion artifacts and low power consumption of the method. Two stage single supply electrocardiogram amplification and analog processing scheme presented. Comparison of the most popular small range wireless data transfer systems and the choice of the optimal one for the sensor was made. Principle of QRS complex discernment from ECG signal presented. Adaptive thresholds were used for QRS complex detection. The principles of adaptive thresholds formation are given. Power consumption minimization possibilities of the sensor discussed. Ill. 7, bibl. 6 (in English; summaries in English, Russian and Lithuanian).

И. Даунорас, Р. Лукочиус, Ю. А. Вирбалис. Датчик пульса системы мониторинга физиологических параметров // Электроника и электротехника. – Каунас: Технология, 2007. – № 6(78). – С. 67–70.

Цель работы – разработать датчик пульса, предназначенный для применения в повседневной жизни человека. Представлены основные методы измерения пульса. Выбран метод вычисления пульса по электрокардиограмме. Метод характеризуется малыми затратами энергии и стойкостью к движению тела. Представлена двухступенчатая схема усиления и аналоговой обработки сигнала. Сравнены наиболее популярные телесистемы передачи данных и выбрана одна из них. Представлен принцип обнаружения QRS комплекса и формирования адаптивных порогов. Обсуждены принципы минимизации расхода энергии источника. Ил. 7, библи. 6 (на английском языке; рефераты на английском, русском и литовском яз.).

J. Daunoras, R. Lukočius, J. A. Virbalis. Fiziologinių parametų stebėjimo sistemos pulso jutiklis // Elektronika ir elektrotechnika. – Kaunas: Technologija, 2007. – Nr. 6(78). – P. 67–70.

Darbo tikslas – sukonstruoti pulso jutiklį, taikomą įprastinėje žmogaus veikloje. Pateikti pagrindiniai pulso nustatymo metodai. Pasirinktas pulso nustatymas iš elektrokardiogramos. Metodas pasižymi dideliu atsparumu žmogaus judesiams ir nedidelėmis energijos sąnaudomis. Pateikta dviejų pakopų vienpolio maitinimo elektrokardiogramos stiprinimo ir analoginio apdorojimo schema. Analizuotos populiariausios nedidelio nuotolio bevielio ryšio duomenų perdavimo sistemos ir parinkta viena iš jų. Pateiktas jutiklyje panaudotas QRS komplekso išskyrimo iš elektrokardiogramos principas. Pateikti slenksčių, naudojamų QRS aptikti, formavimo principai. Aptartos jutiklio energijos sąnaudų minimizavimo galimybės. Il. 7, bibl. 6 (anglų kalba; santraukos anglų, rusų ir lietuvių k.).