

## Research of Control and Management of Data Transmission over Internet Network

P. Tervydis

Department of Electronics Engineering, Kaunas University of Technology,

Studentų str. 50, LT-51368 Kaunas, Lithuania; e-mail: paulius.tervydis@takas.lt

### Introduction

The new data transmission technologies, equipment and their modifications, which are used as infrastructure for data transmissions over Internet network, are continuously developed, updated and installed. To take all advantages of the new data transmission technologies and their new peculiarities, the data transmission control and management algorithms, which are implemented above the data transmission infrastructure, must be continuously researched, revised and updated.

### Object of the research

"Internet" refers [1] to the global information system that -

- is logically linked together by a globally unique address space based on the Internet Protocol (IP) or its subsequent extensions/follow-ons;
- is able to support communications using the Transmission Control Protocol/Internet Protocol (TCP/IP) suite or its subsequent extensions/follow-ons, and/or other IP-compatible protocols; and
- provides, uses or makes accessible, either publicly or privately, high level services layered on the communications and related infrastructure described herein.

Usually, network research objects are classified and attached to separate layers. The five layer model [2] can be applied for the Internet analysis. The model has five layers: *physical*, *link*, *network*, *transport* and *application*. The *physical* layer covers data transmission medium and infrastructure. The *link* layer covers data transmission technologies, their data transmission, control and management processes. Networks, based on different technologies or managed by different providers, are linked together in the *network* layer by a globally unique address space based on the Internet Protocol. Data transmission control and management between the *network* and *application* layers are made in the *transport* layer. The *application* layer acts as an interface for application software of high level services.

The main reason, why the research of control and management of data transmission issues are very important and complicated – the data transmission control and management processes in the *application*, *transport*, *network* and *link* layers (Fig. 1) are independent and separated. The typical scheme of data transmission over Internet is presented in the Fig. 2, a. The data transmission route between terminal stations *A* and *B* is marked out by the bold line. The view of the data transmission route, using the five layer model, is presented in the Fig. 2, b. All five layers can be distinguished in the terminal stations *A* and *B*. The physical data transmission infrastructure is covered by the *physical*, *link* and *network* layers:

- data transmission media is in the *physical* layer;
- network switches 1 and 6 are covered by the *physical* and *link* layers;
- network routers 2 – 5 are covered by the *physical*, *link* and *network* layers.

The description of Internet network and the usage of the five layer model are presented here, to make it clear, that data transmission parameters over the structure are determined by the summation and interaction of data transmission, control, management processes and functional features of components (Fig. 2, b) in every layer. Therefore, the research of control and management of data transmission is very important for efficient data transmission.

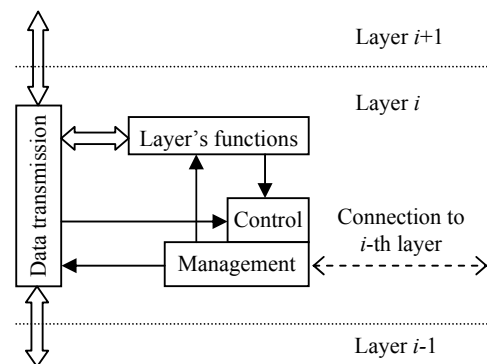
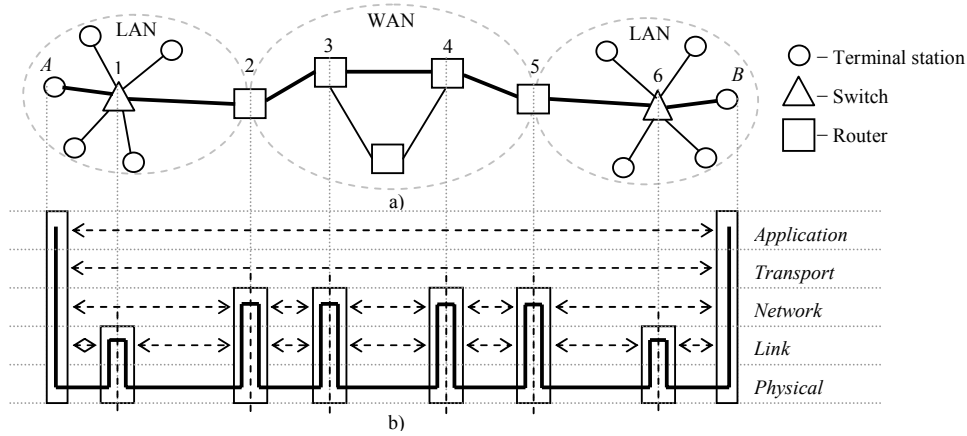

Fig. 1. Scheme of data transmission, control and management in a layer



**Fig. 2.** Data transmission over Internet network between  $A$  and  $B$  terminal stations:  
a) data transmission route over typical Internet architecture;  
b) data transmission route in the five layer model

The data transmission control and management procedures of the *transport* layer are used to control data transmission over Internet network in the terminal stations. Therefore, the research of the data transmission control and management processes of the *transport* layer will be presented in next sections.

### Efficiency of data transmission over Internet network's route

Due to various causes, the rate of data transmission over Internet network is random. Therefore, one of the main tasks of data transmission control and management procedures of the *transport* layer is to determine the data send off rate, which leads to maximum efficiency of data transmission.

Data transmission route (Fig. 2, a) between  $A$  and  $B$  stations is a chain of interconnected network nodes. Data transmission characteristics (delay, packet loss probability and other) over the chain (route or channel) can be analyzed using a single node model, with identical data transmission parameters as in the whole route. The model's scheme is presented in the Fig. 3.

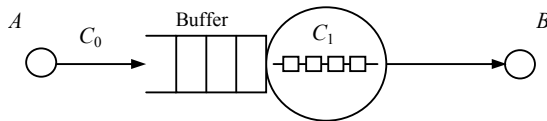

**Fig. 3.** Scheme of data transmission for single node model

The following conditions were taken for the model:

- data is transmitted in one direction ( $A \rightarrow B$ );
- data send off rate  $C_0$  is determined;
- data transmission rate (available bandwidth) over the channel is random, normally distributed ( $C_1 \sim N(\mu_1, \sigma_1)$ ) with known  $\mu_1$  (mean) and  $\sigma_1$  (st. deviation) parameters;
- buffer's capacity is unlimited.

When data send off rate  $C_0$  exceeds data transmission rate  $C_1$  over the channel, the excess data amount is placed

in the buffer. In real networks this case leads to congestions and their consequences: data packet loss due to buffer overloads, increase of transmission delay and high decrease of data transmission rate.

If data send off and transmission rates are expressed as a number of data segments per time unit [dseg/tu], then the mean number of data segments in the buffer is given by

$$\bar{n}_b(C_0, \mu_1, \sigma_1) = \int_0^{C_0} (C_0 - C_1) p(C_1, \mu_1, \sigma_1) dC_1; \quad (1)$$

here  $p(C_1, \mu_1, \sigma_1)$  – density function of  $C_1$  distribution

$$p(C_1, \mu_1, \sigma_1) = \frac{1}{\sigma_1 \sqrt{2\pi}} \cdot \exp\left(-\frac{(C_1 - \mu_1)^2}{2\sigma_1^2}\right). \quad (2)$$

Then the share of data channel's bandwidth for a sent data segment

$$\eta(C_0, \mu_1, \sigma_1) = \frac{1}{1 + \bar{n}_b(C_0, \mu_1, \sigma_1)}. \quad (3)$$

For this model, the efficiency of data transmission over the route can be expressed as the product of channel's load degree ( $C_0/\mu_1$ ) with the share of data channel's bandwidth for a sent data segment

$$E(C_0, \mu_1, \sigma_1) = \frac{C_0}{\mu_1} \cdot \eta(C_0, \mu_1, \sigma_1). \quad (4)$$

The example, how the efficiency relies on the  $C_0/\mu_1$  ratio, is shown in the Fig. 4, where

$$C_0 = 1, 2, 3, \dots, 120 \text{ [kbit/s]}, \quad \mu_1 = 100 \text{ [kbit/s]} \text{ and} \\ \sigma_{11} = 0.5 \text{ [kbit/s]}, \quad \sigma_{12} = 10 \text{ [kbit/s]}, \quad \sigma_{13} = 20 \text{ [kbit/s]}.$$

The efficiency of data transmission over a data transmission channel grows linearly, when  $C_0$  is increased in  $(0; C_{1\min})$  interval. The efficiency starts to decrease, when  $C_0 > C_{1\min}$  and the excess data is placed in the buffer. And, as shown in the Fig. 4, the bigger  $C_1$  variation the smaller  $C_0$  value for which the transmission efficiency reaches its maximum value.

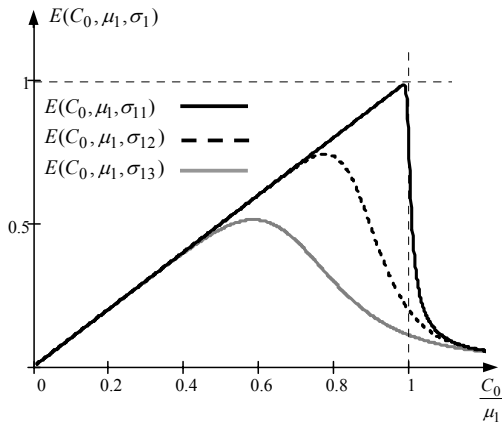

Fig. 4. The efficiency of data transmission over the channel for  $C_0/\mu_1$  ratio

Therefore, to achieve the maximum efficiency of data transmission, the data send off rate  $C_0$  must not to exceed the data channel transmission rate  $C_1$ . For the purpose, the data transmission control and management algorithms, implemented in the *transport* layer, have to continuously control  $C_1$  and to manage  $C_0$  values.

#### Feedback usage for data transmission control and management

Data transmission control and management mechanisms of the *transport* layer do not have direct connections with other (or distant) layers (Fig. 1, Fig. 2, b – dashed arrow lines). Connection opening, closing and data transmission control procedures are made using feedback information. Therefore, the data transmission over Internet network consists of a number of data transmission cycles, where data is transmitted from one terminal station to another and acknowledged (*ACK*) in the backward direction.

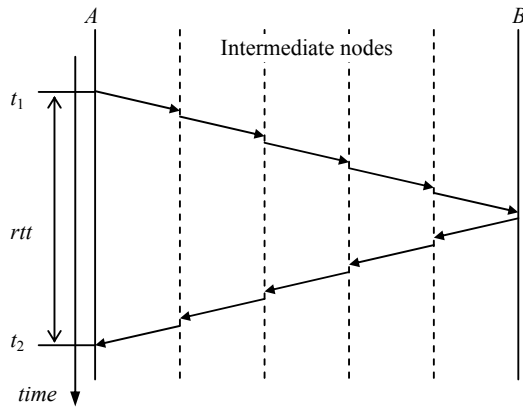

Fig. 5. Diagram of data transmission cycle

For each  $i$ -th data transmission cycle, the feedback communications between terminal stations  $A$  and  $B$  are used to:

- manage the amount of data (window –  $w_{i+1}$ ), that can be sent in next ( $i+1$ ) transmission cycle;

- determine the value  $rtt_i$  of round-trip-time (*RTT*) between data segment's send off time moment  $t_1$  and acknowledge (*ACK*) arrival time moment  $t_2$  (Fig. 5);
- acknowledge, what amount of data is successfully received;
- inform, what amount of data (receiver window  $rw_{i+1}$ ) can be received in next transmission cycle. If  $rw_i < w_{i+1}$ , then  $w_{i+1} \leftarrow rw_{i+1}$ , this way, the data send off rate is managed to be not bigger than data process rate of the remote station ( $C_A$  and  $C_B$ ).

Considering the mentioned, more complicated model should be used (Fig. 6) to analyze the data transmission control and management procedures of TCP realizations.

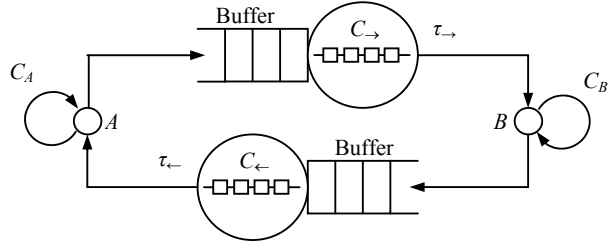

Fig. 6. Model's scheme for data transmission with feedback

General mathematic model of *RTT* value for  $i$ -th transmission cycle can be expressed by:

$$rtt_i = t_A + \tau_{\rightarrow} + \frac{w_i}{C_{\rightarrow}} + \tau_{\leftarrow} + \frac{ack_i}{C_{\leftarrow}} + t_B; \quad (5)$$

here  $\tau_{\rightarrow}$  and  $\tau_{\leftarrow}$  – signal propagation time for up and down directions;

$C_{\rightarrow}$  and  $C_{\leftarrow}$  – data transmission rate for up and down directions;

$w_i$  – size of transmitted data;

$ack_i$  – size of an acknowledge data;

$t_A$  and  $t_B$  – data process (preparation, transmission, reconstruction, reception) time in terminal stations.

Data transmission parameters over Internet network's route (over *physical*, *link* and *network* layers) can be estimated using the ICMP (RFC 792) based programs. The program (Fig. 7), which collects and saves *RTT* values ( $rtt$ ) for detailed analysis, was developed.

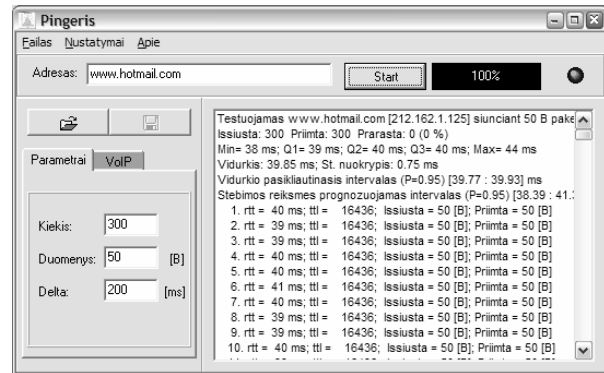
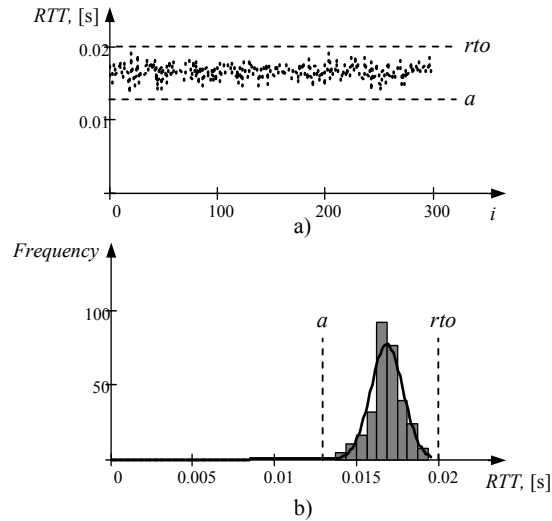

Fig. 7. The program for *RTT* value measurement and analysis

Using the program, a lot of *RTT* measurements for different routes and from different terminal stations were made. Collected *RTT* statistics of data transmission in real Internet network show, that *RTT* values of data transmission over any channel cannot be lower than, particular for that route, fixed *RTT* component *a* and are randomly distributed over (*a*; *rto*) interval (if acknowledgement for a data segment is not received after *rto*, the data segment is sent again). For illustration, one of the *RTT* measurement results is presented in the Fig. 8. The test packets of 50 bytes were sent 300 times. The *rto* value was set to 0.02 seconds.



**Fig. 8.** Round-trip-time measurement results:  
a) measured  $rtt_i$  values ( $i = 1, 2 \dots n; n = 300$ );  
b) histogram of the measured *RTT* values with normal fitting

The fixed *RTT* component *a* is caused by:

- physical features of data transmission medium (length, signal propagation speed);
- minimal and unavoidable data transmission process duration in a number of intermediate nodes.

The random *RTT* component is caused by:

- variety of data transmission technologies, topologies and their data transmission processes;
- random nature of user created data flow;
- available amount of network route's bandwidth;
- error of *RTT* value's measurement.

### Bandwidth estimation problem

It was proven, that to achieve a high efficiency of data transmission over Internet, it is necessary to control data transmission rate  $C_1$  and to manage the data send off rate  $C_0$ . The correct estimation of  $C_1$  values is the most difficult part of such approach. It is obvious, that in case of wrong estimation, the data transmission process will be ineffective.

Old, modified and currently used TCP realizations [2, 3, 4]: Tahoe, Reno, New Reno – do not try to estimate the  $C_1$  value. Data send off rate  $C_0$  (or  $w_i$  of *i*-th transmission cycle) is increased until *time-out* event for *ACK* receive occurs, or the data receiver (*B*) asks sender in *ACK* packet

to decrease  $C_0$ , when  $C_0 > C_B$  (Fig. 6). Such  $C_0$  management leads to network congestions and data packet loss, when data process rates in terminal stations ( $C_A$  and  $C_B$ )  $> C_1$ . To solve the problem some new TCP realizations were proposed, the most popular and widely presented [3,4] is Vegas. TCP Vegas adopts a sophisticated bandwidth estimation scheme. It uses the difference between expected and actual data flows rates to estimate the available bandwidth in the network. The idea is that when the network is not congested, the actual data flow rate will be close to the expected. Otherwise, the actual data flow rate will be smaller than the expected data flow rate. TCP Vegas, using this difference in data flow rates, estimates the congestion level in the network and updates the data send off rate  $C_0$  accordingly [4]. The expected data flow rate for each *i*-th transmission cycle is calculated by

$$C_{ex_i} = \frac{w_i}{rtt_{min}}, \quad (6)$$

the actual data transmission rate is given by

$$C_{act_i} = \frac{w_i}{rtt_i}. \quad (7)$$

Where  $w_i$  is the current window size,  $rtt_{min}$  – minimum *RTT* value and  $rtt_i$  – actual *RTT* value.

Why such bandwidth estimation must be revised will be analyzed in the next section.

### Proposed bandwidth estimation method

Using the *RTT* value analysis program (Fig. 7), it was determined, that the *RTT* values are related to the length (*L*) of test packets. To check the reliance, the program was modified: the length (*L*) of test packets is increased by 50 bytes for each 10-th collected *RTT* sample, and the measurement stops when 10-th *RTT* sample for 1000 byte test packets is measured. The collected *RTT* samples as grey dots are presented in the Fig. 9.

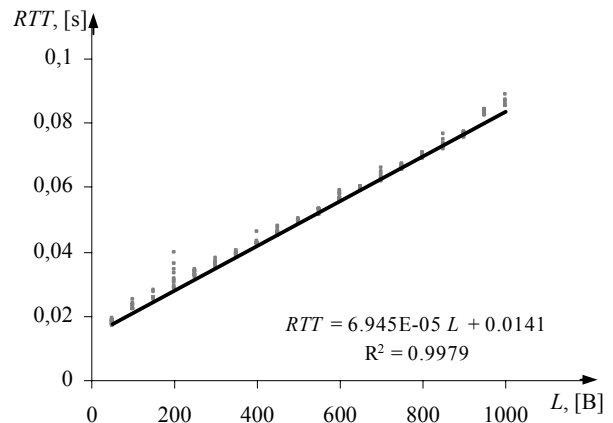

**Fig. 9.** The actual bandwidth estimation using linear regression

It is clear, that the increase of *RTT* values is linearly related to the test packet length. Therefore, the linear regression model [5] can be used for the reliance analysis. It was determined, that the most accurate results are



## Conclusions

The main reason, why it is very difficult to find the optimal algorithm for control and management of data transmission over Internet network, lies in the concept of Internet as layered system, where data transmission parameters are determined using feedback information.

The efficiency of data transmission could be increased, if during connection opening and data transmission phases, the terminal stations could get direct information about the exact bandwidth of the data transmission route (the minimal data transmission rate of an intermediate node) from the lower layers. Having such information, the procedures of the *transport* layer could be simplified and more efficient.

## References

1. **FNC Resolution:** Definition of "Internet". – [http://www.nitrd.gov/fnc/Internet\\_res.html](http://www.nitrd.gov/fnc/Internet_res.html)
2. **Tanenbaum A. S.** Computer Networks, Fourth Edition. – Prentice Hall, 2003. – 912 P.
3. **Pavilanskas L.** TCP protokolo modeliavimas bevieliame tinkle // Elektronika ir elektrotechnika. – Kaunas: Technologija, 2005.– Nr. 5(61). – P. 78–83.
4. **Cheng Fu P., Soung Liew C.** A Remedy for Performance Degradation of TCP Vegas in Asymmetric Networks // IEEE Communications Letters, Vol. 7, No. 1, January, 2003. – P. 42–44.
5. **Čekanavičius V., Murauskas G.** Statistika ir jos taikymai. II knyga. – Vilnius: TEV, 2004. – 270 P.

Submitted for publication 2006 03 01

### **P. Tervydis. Research of Control and Management of Data Transmission over Internet Network // Electronics and Electrical Engineering. – Kaunas: Technologija, 2006. – No. 5(69). – P. 57–62.**

The problem of control and management of data transmission over Internet network is presented. The short review of Internet network, its layers and data transmission control and management issues is given. The model, that can be used to estimate the efficiency of data transmission over Internet's route, is presented. The problem of correct bandwidth estimation for effective data transmission over Internet is explained. Feedback usage for data transmission control and management is explained. The mathematic model for round-trip-time value was created, using the results of two applications, which were developed to collect statistics of real data transmission over Internet's route. The method, based on linear regression, was proposed for more precise bandwidth estimation. Ill. 11, bibl. 5 (in English; summaries in English, Russian and Lithuanian).

### **П. Тервидис. Исследование контроля и управления передачей данных в Интернет сети // Электроника и электротехника. – Каунас: Технология, 2006. – № 5(69). – С. 57–62.**

Обозначены проблемы, представляемые для контроля и управления передачей данных в Интернет сети. Сделан короткий обзор самой Интернет сети и ее слоев. Создана модель, которая позволяет определить эффективность передачи данных по Интернет маршруту. Представлена проблема правильной оценки пропускной способности для эффективной передачи данных в Интернет сети. Используя результаты двух программ, которые были созданы, чтобы собрать статистику реальной передачи данных по Интернет маршруту, создана математическая модель, которая позволяет определить значение времени передачи данных между конечными станциями. Предложен метод, основанный на линейном регрессе, для более точной оценки пропускной способности. Ил. 11, библи. 5 (на английском языке, рефераты на английском, русском и литовском яз.).

### **P. Tervydis. Duomenų perdavimo interneto tinklu kontrolės ir valdymo tyrimas // Elektronika ir elektrotechnika. – Kaunas: Technologija, 2006. – Nr. 5(69). – P. 57–62.**

Pateikta duomenų perdavimo interneto tinklu kontrolės ir valdymo problema. Trumpai apžvelgti interneto tinklo, jo lygmenų, bei duomenų perdavimo interneto tinklu kontrolės ir valdymo ypatumai. Sukurtas modelis, leidžiantis įvertinti duomenų perdavimo interneto tinklo maršrutu efektyvumą. Įrodyta, kokią įtaką tikslios duomenų perdavimo kanalu spartos nustatymas turi efektyviam duomenų perdavimui. Naudojant dviejų programų, kurios buvo sukurtos duomenų perdavimo interneto tinklo maršrutu charakteristikų statistikai surinkti, rezultatus, sudarytas matematinis modelis, aprašantis duomenų perdavimo tarp galinių stočių trukmės priklausomybę. Pasiūlytas metodas, leidžiantis tiksliau nustatyti duomenų perdavimo maršrutu spartą (pralaidumą). Il. 11, bibl. 5 (anglų kalba; santraukos anglų, rusų ir lietuvių k.).