

Fracture investigation of layered composite structural elements

A. Žiliukas*, N. Meslinas**, K. Juzėnas***

*Kaunas University of Technology, Kęstučio 27, 44025 Kaunas, Lithuania, E-mail: antanas.ziliukas@ktu.lt

**Kaunas University of Technology, Kęstučio 27, 44025 Kaunas, Lithuania, E-mail: nerijus.meslinas@ktu.lt

***Kaunas University of Technology, Kęstučio 27, 44025 Kaunas, Lithuania, E-mail: kazimieras.juzenas@ktu.lt

1. Introduction

Applications of composite materials in various structures give great possibilities of their design and ensure better qualitative and quantitative properties of those structures. In many cases such structural elements have several layers of homogenous or composite materials characterised by very different mechanical, chemical, thermal, electrical and other properties.

Layered composite structures are often used for military purposes (composite armor), in means of transportation, pipes, structural elements of buildings, etc. [1, 2]. Several examples of such structures are given in Fig. 1. It has to be mentioned, that their functions and, therefore, mechanical properties of certain layers can differ significantly. For example, there are outside layers made of glass, carbon, aramid, kevlar or other fibres and epoxy, phenol, vinyl ester or other resins with relatively high mechanical properties (tensile strength, Young's modulus) and inner layer made of very hard (ceramics) or light materials (balsa wood, metal foams, polymer foams, rubber, thermoplastic polymers, etc.) with relatively low mechanical properties in most structures. Usually, hard materials are used aiming to improve ballistic properties of composite structures (armors) and soft materials are used as structural layers, heat isolation layers, etc.

Naturally, mechanical and other properties of the whole complex structure differ significantly from those of certain layers. Performance of such structures in various conditions of exploitation, under various loads is very complicated and there are almost no generalized and easy to use methods for precise calculations aiming to optimize design of such structures. Lots of scientific research works are focused on the analysis of composites properties trying to improve their design and functionality [2-4]. It is especially truth in the analysis of fracture processes [5-7] because those processes differ significantly in various materials, in various layers, in structures of different composition, etc. Mechanisms of crack opening, fracture of different layers and delamination of the layers depend on properties of materials, size and design of the layers and the whole structural element, type and direction of loads and are not properly investigated.

Recent practice to determinate mechanical properties or analyze fracture mechanism of complex layered structures experimentally or applying complicated numerical modelling procedures is expensive and is not always acceptable (e.g. just several elements of their kind are produced). Therefore authors of this paper are trying to compose the simplified methodology of fracture analysis which could be used for initial calculations of layered composite structures aiming to analyze the mechanism of their frac-

ture. That would help to improve their design in the initial stage without any expensive and time consuming experimental research or complicated numerical modelling.

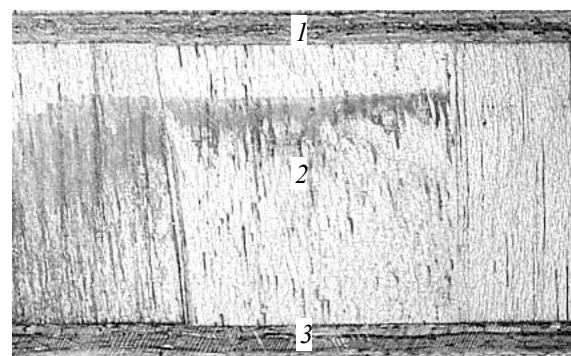
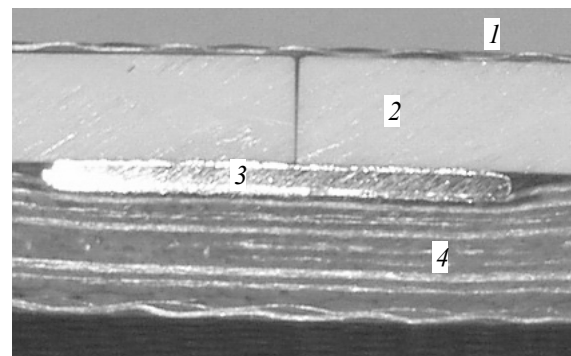
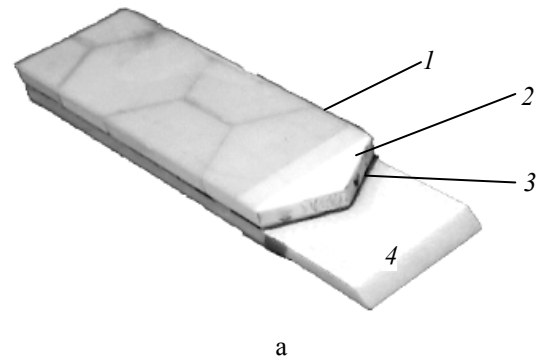

Fig. 1 Multilayer composite structures. Here a) 1 - glass fibre/ epoxy cover layer, 2 - alumina ceramic layer, 3 - rubber layer and 4 - glass fibre/ epoxy layer; b) 1 - glass fibre/ epoxy layer, 2 - alumina ceramic layer, 3 - steel plate and 4 - glass fibre/ epoxy layer; c) 1 - glass fibre/ vinyl ester layer, 2 - balsa wood layer, 3 - glass fibre/ vinyl ester layer

2. Mathematical modelling of the fracture process

Some simplifications were accepted in current research of the layered structures. Only three layer structures are analyzed aiming to reduce initial research amount and verification of its results. Many structural elements can be analysed as three layer structures, because some external layers are designed relatively thin and are used as external covers of the structures. They should resist to external media (e.g. moisture, heat, flames, etc.) and do not influence mechanical properties of the whole structure significantly. Some internal elements (e.g. element 3 in Fig. 1, b) are specific just for some relatively rare designs of such structures and can be eliminated in generalised models of layered structural elements. Therefore such simplification is acceptable, because it covers significant amount of composite layered structures, allows analysis of the inner and outer layers properties and their interaction, processes in interlayers and can be adjusted for more complex structures in further research.

Although exploitation conditions and functions of layered structural elements differ (e.g. composite armor should withstand ballistic impacts), most of such structural elements are loaded by bending forces during long periods of their exploitation. Therefore it is important to analyse behaviour and fracture of those structures in case of bending loads. Often the structures and certain elements are loaded in a way that pure four point bending is created. Such type of loading reduces the maximum moment of bending and distributes stresses more equally in every cross-section. Analysis of this case allows the simplification of composed analytical and numerical models in current research stage. Consequently the maximum stresses are obtained next to the peak of an initial crack (concentrator of stresses). Plastic zones of strains are formed the crack peak and have the shape similar to the sign of infinity. Areas of strains change their location and size depending on strains next to the peak of the crack when critical level of load is reached. Such location of strains influences the formation of remote zones of strains and mechanisms of fracture process in cases of layered structures.

Calculations of homogeneous isotropic materials are limited to the calculations of plastic strain's zones where stresses are higher than the yield strength in the classical fracture mechanics [8]. It is also known that the decrease of stresses is exponential, receding from the peak of a crack. Even in a distance from the peak of a crack equal to 5 – 10 values of radius of plastic strain areas, the decrease of stresses is already 2 – 3 times and the stresses are lower than limit of yield strength for a certain material. Strains at the peak of a crack in case of plane state of stresses can be calculated:

$$\varepsilon = \frac{K_1}{E\sqrt{2\pi r}} \cos \left(\frac{\Theta}{2} \sqrt{1+3\sin^2 \frac{\Theta}{2}} \frac{1+\frac{r}{l}}{\sqrt{1+\frac{r}{2l}}} \right) \quad (1)$$

here E is Young's modulus of material; Θ is the angle of plastic strain's area next to the peak of a crack; r is the distance between remote area of plastic strains and the crack; l is initial length of the crack.

In case of plane strains

$$\varepsilon = \frac{K_1}{E\sqrt{2\pi r}} \cos \left(\frac{\Theta}{2} \sqrt{(1-2\nu)^2 + 3\sin^2 \frac{\Theta}{2}} \frac{1+\frac{r}{l}}{\sqrt{1+\frac{r}{2l}}} \right) \quad (2)$$

here ν is Poisson's ration.

Factor of stresses intensity K_1 for a beam on two supports in case of pure point bending

$$K_1 = \frac{F(L-L_1)}{t\sqrt{b^3}} Y_4 \quad (3)$$

here L is the distance between supports; F is the force of load; b is the height of a specimen; t is the thickness of a specimen; L_1 is distance between supports of a loading device. Coefficient

$$Y_4 = 3.494 \left(1 - 3.396 \left(\frac{l}{b} \right) + 5.839 \left(\frac{l}{b} \right)^2 \right) \quad (4)$$

If a layer of the material, characterised by several times lower yield strength, is inserted at a distance from the crack peak close in value to the radius of plastic strain's areas, the secondary areas of plastic strains emerge in that layer. Changes of normal stresses in any layer of a structural element, passing from one layer i into another layer $i+1$, is proportional to the ratio of Young's modulus of materials used for those layers

$$\sigma_{i+1} = \sigma_i \frac{E_{i+1}}{E_i} \quad (5)$$

When load is increasing, stresses reach critical values and the process of fracture begins. Crack grows in the direction of largest strains. At the same time, secondary areas of plastic strains emerge in the stressed layer. Crack grows perpendicularly to the plane of stressed layer. Peak of the crack changes its propagation direction when it reaches the inner layer where areas of plastic strains already emerged. In ideal case, the crack splits into two cracks, because two areas of the ultimate plastic deformations are formed in the inner layer.

3. Experiments

Experiments were carried out in the conditions corresponding to pure bending because adhesion makes impossible experiments of non-centric tension. In this stage of research, experiments were planned just aiming to analyze and validate an idea of the formation of remote areas of strains in layered structural elements. Therefore the goal of experiments was to determine emerging of the secondary areas of remote strains in inserted layer for the case of pure point bending and analyze the influence of those zones in the direction of crack's growth.

Specimens of three layer structures were designed for experimental research. They were composed of two outer layers of aluminium alloy and inner layer of solidi-

fied epoxy resin. Such design of the specimens corresponds to the design of many layered composite structures (e.g. pipes, armors, panels of building, etc.) that have elastic external layers characterised by excellent mechanical properties and quite brittle internal layers. Mechanical properties of the brittle layer of epoxy resin are much lower than the properties of elastic-plastic alloy of aluminium. Main mechanical characteristics of the used materials are given in the Table.

Table
Main mechanical characteristics of layer's materials

Material	Yield strength σ_y , MPa	Ultimate strength σ_u , MPa	Young's modulus E , GPa
Aluminium	170	215	72
Epoxy resin	65	80	5

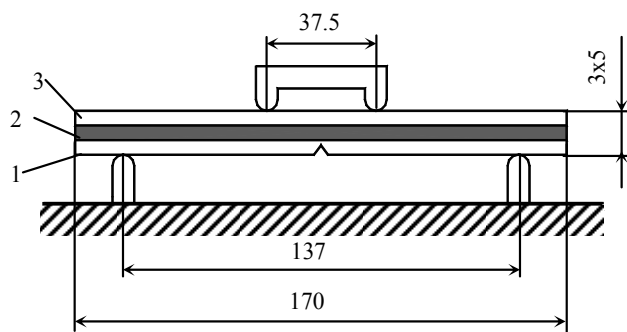

Fig. 2 Geometry of a specimen and location of its supports: 1, 2, 3 are different layers of the specimen

Geometric characteristics of the specimens of layered structures used in the experiments are: length $L = 170$ mm, width is 15 mm, thickness of the first and the third layers are $h_1 = h_3 = 5$ mm, thickness of the inserted layer (2-nd layer) is $h_2 = 5$ mm (Fig. 2). The distance between supports of the specimen is 137 mm and the distance between contact points of a loading element is 37.5 mm. An artificially made initial crack is machined in the first layer (Fig. 3). It works as a concentrator of stresses. Geometry of the initial crack: width $s = 3$ mm, depth $h = 3$ mm, angle of crack's peak $\alpha = 26.56^\circ$.

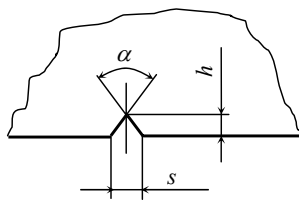
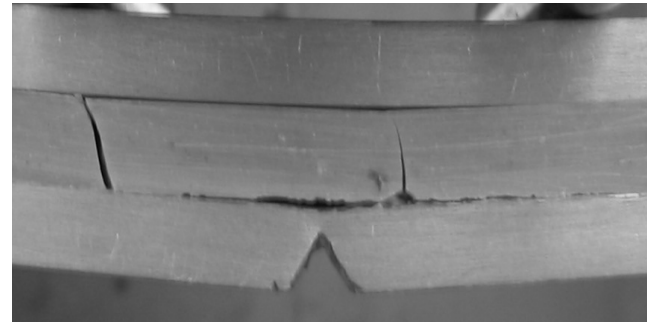

Fig. 3 Geometry of an artificially made crack

Delamination between the first and the second layers begins when the specimen is deformed under applied force. Secondary remote areas of strains emerge in the inner layer and this inner element cracks beside those remote areas of strains perpendicularly to the direction of the layers (Fig. 4, a). Cracks develop in the direction of maximum stresses. Maximum values of the load can be reached and cracks cross the whole inner layer. The first layer breaks in case then the load is increased even more (Fig. 4, b). However further deforming of the specimen is

irrelevant, because maximum value of the load is already reached and the layered structure has lost its integrity.

Forces F corresponding to the ultimate strength and distance to remote areas of strains r were measured during this experiment. Experimental results were analyzed applying common methodology and means of statistic data analysis. It was obtained that load force corresponding to the ultimate strength of specimens in the case of pure bending is $F = 5025.4 \pm 158$ N and the distance from the initial crack to remote areas of strains $r = 17.31 \pm 0.46$ mm. Those results were used in further analytical calculations aiming to calculate stresses in the inner layer of experimental layered composite structures.



a

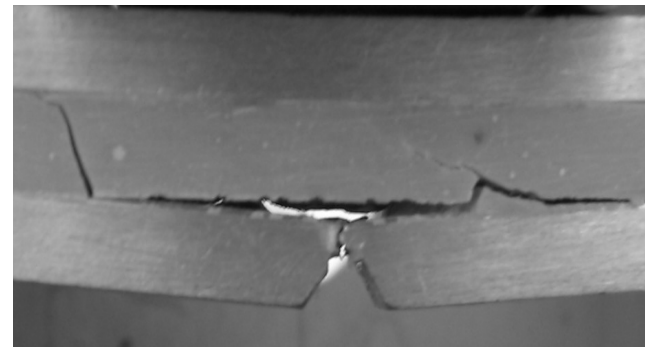

b

Fig. 4 Fracture of specimens in the case of pure bending: a - delamination and cracking of the inner layer; b - cracking of external layer

Usage of experimental data (value of load force and geometric characteristics) in the analytical model allows verifying of this model. Analytical calculations using equations 1-5 show that stresses in the inner element of the structure next to remote areas of strains (in distance $r = 17.31$ mm from the peak of the initial crack) under critical load $F = 5025.4$ N have the value of $\sigma = 66.75$ MPa. This value of stresses is similar to the yield strength of epoxy resin used in the experiments (see Table). Therefore results of the analytical calculations show that stresses in the material of inserted layer at some distance from the peak of a crack have values similar to the value of material's yield strength.

Concentration of stresses and changes of crack's growth direction were observed in those locations during the experiments. It proves the existence of remote areas of strains in the inner layer of similar layered composite structures and shows the nature of their fracture process.

4. Numerical modelling

The process of fracture of layered composite structure, analogous to the one used in the experimental research, was numerically modelled applying the method of finite elements. ANSYS software and PLANE 182 finite elements were used for numerical modelling of fracture process. Those elements are designed for modelling of stresses and strains in planes. PLANE 182 elements have four nodes and two degrees of freedom.

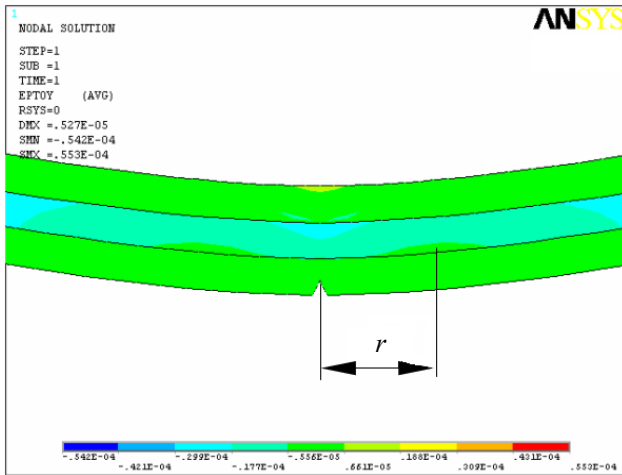

Fig. 5 Distribution of strains in y direction (perpendicular to the layers). r is the distance from the initial crack peak to the area of remote strains

The same mechanical properties of layer's materials as given in the Table above were used in numerical simulation of fracture of layered composite structures.

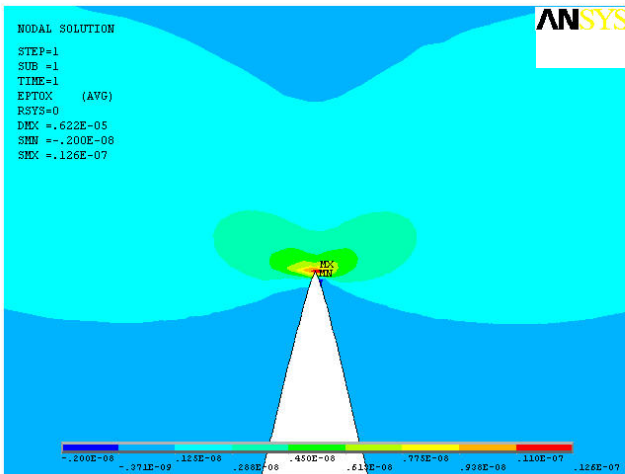

Fig. 6 Distribution of strains next to the peak of opened crack in x direction (along modelled specimen)

Graphical results of the modelling are presented in Figs. 5 - 7. The distance of remote areas of strains can be noted in all those pictures. Figs. 5 and 6 show modelled distribution of strains in the directions of y and x axes. Analytically calculated radius of plastic strain's areas r is shown in Fig. 5.

Generalised distribution of strains according to Misses criterion is shown in Fig. 7. Values of equivalent stresses numerically modelled according to Misses criterion next to remote areas of strains are corresponding to

the values of stresses in the same location, calculated using the proposed analytical method.

It can be noted that calculations of stresses using results of the numerical modelling at the distance equal to experimentally obtained values of r , shows that the values of stresses in the material of outer layers do not exceed yield strength, but the stresses are similar to the yield strength in the inner layer material. That corresponds to the experimental results, presented in Chapter 3.

Therefore it can be stated that numerical simulation validates the proposed analytical model of fracture process of layered structures.

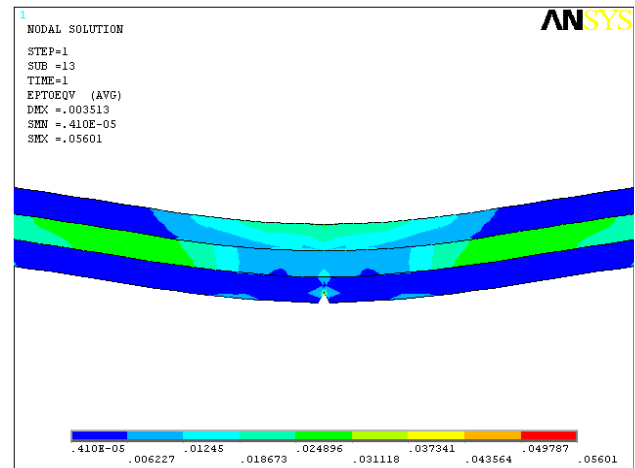

Fig. 7 Distribution of strains in accordance to Misses criterion

5. Conclusions and discussion

The proposed analytical model of fracture process of layered composite structures with three layers characterised by quite different mechanical characteristics was validated experimentally and using means of numerical modelling applying the method of finite elements.

Results obtained using all three methods of research are similar and prove correctness of the analytical model. Therefore it can be stated that such quite simple analytical model can be used for practical calculations of fracture in such layered composite structures.

Evidently further developments of this analytical model are needed in order to adapt it for various designs of composite layered structures with different number, thickness and properties of the layers.

References

1. Mouritz, A.P., Gellert, E., Burchill, P., Challis, K. Review of advanced composite structures for naval ships and submarines. -Composite Structures, 2001, No53, p.21-41.
2. Horsfall, I., Austin, S.J., Bishop, W. Structural ballistic armour for transport aircraft. -Materials and Design, 2000, No21, p.19-25.
3. McHenry, E., Stachurski, Z.H. Composite materials based on wood and nylon fibre.- Composites: Part A, 2003, No34, p.1-11.
4. Lopez-Anido, R., Barbero, E.J., Davalos, J.F. Experimental evaluation of stiffness of laminated composite beam elements under flexure.- J. of Reinforced Plas-

- tics and Composites, 1995, No14(4), p.349-361.
5. **He, J.W., Jia, M., Wen, S.P., Li, N.** Cracking in the soft interface layer of an Al-alloy laminate.-Int. J. of Fatigue, 2003, No25, p.421-426.
 6. **Donaldson, S.L.** Fracture toughness testing of graphite (epoxy and graphite) PEEK composites.- Composites, 1985, v.16, No2, p.103-112.
 7. **Žiliukas, A.** Universal fracture criterion in the LBB concept.- 14th Int. Conference on Structural Mechanics in Reactor Technology.-Lyon, France, August 17-22, 1997, v.4, p.285-291.
 8. **Žiliukas A.** Deformuojamų kūnų mechanika: tamprumo ir plastiškumo teorija. Irimo mechanika.-Kaunas: Technologija, 1994.-220p.

A. Žiliukas, N. Meslinas, K. Juzėnas

SLUOKSNIUOTŲ KOMPOZITINIŲ KONSTRUKCINIŲ ELEMENTŲ IRIMO TYRIMAS

Re z i u m ė

Straipsnyje nagrinėjamas sluoksniuotų kompozitinių konstrukcinių elementų irimas. Pateikiamos sluoksniuotų kompozitinių elementų konstrukcijos ir tokių elementų irimo procesui tirti sukurtas supaprastintas analitinis modelis. Šis gana nesudėtingas modelis gali būti panaudotas kuriant sluoksniuotų konstrukcinių elementų projektavimo ir irimo tyrimų metodikas.

Analitinio modelio rezultatai yra patikrinti eksperimentiškai ir modeliuojant baigtinių elementų metodu. Eksperimentiniai ir modeliavimo rezultatai atitinka rezultatus gautus analitiškai, kas patvirtina analitinio modelio teisingumą.

A. Žiliukas, N. Meslinas, K. Juzėnas

FRACTURE INVESTIGATION OF LAYERED COMPOSITE STRUCTURAL ELEMENTS

S u m m a r y

Fracture of layered composite structural elements is analysed in this article. Some designs of layered composite structural elements and simplified analytical model composed for the analysis of their fracture process are presented. This relatively simple model can be used developing the methodologies for design and fracture analysis of layered structural elements.

Results, obtained applying analytical model, were verified experimentally and employing the method of finite elements. Experimental and modelled results correspond to analytically calculated results what validates correctness of the analytical model.

A. Жилюкас, Н. Меслинас, К. Юзенас

ИССЛЕДОВАНИЕ РАЗРУШЕНИЯ МНОГОСЛОЙНЫХ КОМПОЗИТНЫХ СТРУКТУРНЫХ ЭЛЕМЕНТОВ

Р е з ю м е

В статье анализируется разрушение в слоистых конструкционных элементах. Представлены различные конструкции слоистых элементов и составлена упрощенная аналитическая модель для анализа процесса разрушения этих конструкций. Эта относительно простая модель может использоваться для развития методологии проектирования и анализа разрушения слоистых конструкционных элементов. Результаты, полученные предлагаемой аналитической моделью, были проверены экспериментально и методом конечных элементов. Экспериментальные результаты и результаты, получены методом конечных элементов, подтверждают правильность аналитической модели.

Received May 11, 2005