

Electric Circuit Analysis using Finite Element Modeling

J. Sveikata

Department of Signal Processing, Kaunas University of Technology,
Studentų str. 50, LT-51368 Kaunas, Lithuania, phone: +370 37 300528, e-mail sveikata@tef.ktu.lt

P. Tarvydas, A. Noreika

Department of Electronics Engineering, Kaunas University of Technology,
Studentų str. 50, LT-51368 Kaunas, Lithuania, phone: +370 37 300524, e-mail alius.noreika@stud.ktu.lt

Introduction

Electric circuit analysis determines the voltage and current distribution in an electric circuit due to applied source voltages or currents. In a static (DC) electric circuit analysis, the voltage and current distribution in an electric circuit is determined that is subjected to applied DC source voltages or currents. In a harmonic (AC) electric circuit analysis, the voltage and current distribution in an electric circuit is determined that is subjected to applied AC source voltages or currents. A transient electric circuit analysis analyzes an electric circuit subjected to time-varying source voltage or currents. The analysis determines the voltage and current distribution in an electric circuit as a function of time.

Realizing the full potential of FEA simulation in electromagnetics requires complete flexibility in simulating circuit-fed electromagnetic devices. The *ANSYS/Emag* program (ANSYS Inc.) has the following capabilities for circuit analysis: a modified nodal analysis method for simulating circuits; direct coupling of circuits to stranded coils and massive conductors; coupling for both 2-D and 3-D models; support for DC, AC, and time-transient simulations. The advanced circuit-coupled simulation available in the *ANSYS/Emag* program allows for accurate simulation of items such as those listed below: solenoid actuators; transformers; AC machines.

Modeling linear circuits with *CIRCU124* element

ANSYS provides a general circuit element, *CIRCU124* [1-3], for simulating linear circuits. The circuit elements solve for unknown nodal voltages (and currents, in some instances). Electric circuits consist of components such as resistors, inductors, mutual inductors, capacitors, independent current and voltage sources, and dependent current and voltage sources (Table 1-3). It is possible model all of these using *CIRCU124*. *CIRCU124* is applicable to static, harmonic, and transient analyses.

The element *CIRCU124* may also interface with electromagnetic finite elements to simulate coupled electromagnetic-circuit field interaction. The element has up to 6 nodes to define the circuit component and up to

three degrees of freedom per node to model the circuit response. For electromagnetic-circuit field coupling, the element may interface with *PLANE53* and *SOLID97*, the 2-D and 3-D electromagnetic field elements [3,5].

The element is defined by active and passive circuit nodes. Active nodes are those connected to an overall electric circuit, and passive nodes are those used internally by the element and not connected to the circuit. For the coupled circuit source options, the passive nodes are actual nodes of a source conductor modeled in the electromagnetic field domain.

Table 1. *CIRCU124* Circuit Element Options

Circuit option	KEYOPT(1)	DOF	Real constants
Resistor	0	VOLT	R1 – Resistance (RES)
Inductor	1	VOLT	R1 – Inductance (IND) R2 – Initial inductor current (ILO)
Capacitor	2	VOLT	R1 – Capacitance (CAP) R2 – Initial capacitor voltage (VCO)
Mutual inductor	8	VOLT	R1 – Primary inductance (IND1) R2 – Secondary inductance (IND2) R3 – Coupling coefficient (K)

Table 2. *CIRCU124* Circuit Source Options

Circuit option	KEYOPT(1)	DOF	Real constants
Independent current source	3	VOLT	For KEYOPT(2)=0: R1 – Amplitude (AMPL) R2 – Phase angle (PHAS) For KEYOPT(2)>0: see Fig. ?
Independent voltage source	4	VOLT(I,J) CURR(K)	For KEYOPT(2)=0: R1 – Amplitude (AMPL) R2 – Phase angle (PHAS) For KEYOPT(2)>0: see Fig. ?
Voltage-controlled current source	9	VOLT	R1 – Transconductance (GT)
Voltage-controlled voltage source	10	VOLT(I,J,L,M) CURR(K)	R1 – Voltage gain (AV)
Current-controlled voltage source	11	VOLT(I,J,L,M) CURR(K,N)	R1 – Transresistance (RT)
Current-controlled current source	12	VOLT(I,J,L,M) CURR(K,N)	R1 – Current gain (AI)

Element circuit components (Table 1), sources (Table 2), and coupled sources (Table 3) are defined by *KEYOPT(1)* settings and its corresponding real constants. For example, setting *KEYOPT(1)* to 2 causes *CIRCU124* to model a capacitor. Real constant input is dependent on the element circuit option used. A summary of the element

input options is given in Tables 1-3. The element is characterized by up to three degrees of freedom (DOF): *VOLT* (voltage), *CURR* (current), *EMF* (potential drop). For all circuit components, positive current flows from node I to node J.

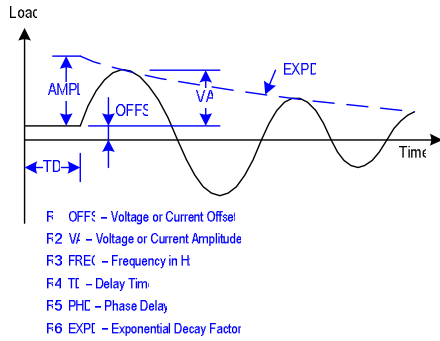

Fig. 1. Sinusoidal load (*KEYOPT*(2)=1)

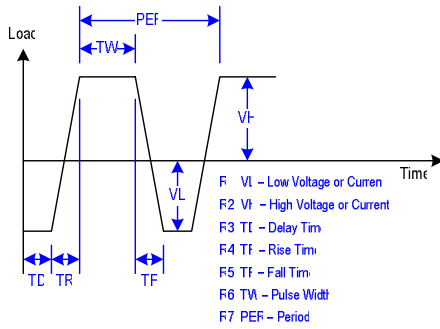

Fig. 2. Pulse load (*KEYOPT*(2)=2)

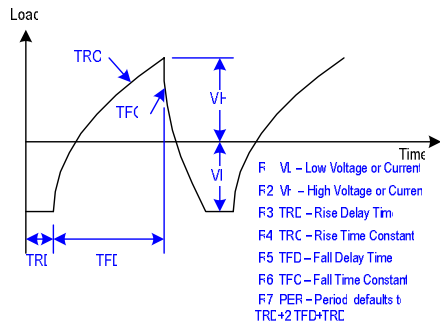

Fig. 3. Exponential load (*KEYOPT*(2)=3)

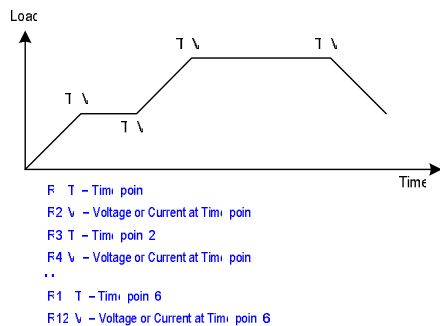

Fig. 4. Piecewise linear load (*KEYOPT*(2)=4)

Independent current (*KEYOPT*(1)=3) and voltage (*KEYOPT*(1)=4) sources may be excited by AC/DC, sinusoidal, pulse, exponential, or piecewise linear load functions as defined by *KEYOPT*(2) (Fig. 1-4).

Three circuit components are available to couple the FEA domain to the circuit domain (Table 3). These components hook directly into conductors in the finite element model.

Table 3. CIRCUI24 Coupled Circuit Source Options

Circuit option	KEYOPT(1)	DOF	Real constants
Stranded coil 2-D or 3-D	5	VOLT(I,J) CURR(K) EMF(K)	R1 – Symmetry factor (SCAL)
Massive conductor 2-D	6	VOLT(I,J) CURR(K) EMF(K)	R1 – Symmetry factor (SCAL)
Massive conductor 3-D	7	VOLT(I,J,K,L) CURR(K,L)	R1 – Symmetry factor (SCAL)

No eddy currents can exist in the stranded coil connection. The magnetic vector potential (MVP) and current determine the coil voltage. Expressed as equations, the connection is:

$$\Delta V = R_C + \frac{\partial \psi}{\partial t}, \quad (1)$$

$$\Delta V = R_C + \frac{n_C}{S_C} \int \frac{\partial \bar{A}}{\partial t} d\bar{S}, \quad (2)$$

where R_C – the coil resistance, n_C – the number of coil turns, S_C – the coil cross-section area.

The massive conductor connections take skin effects into account. In these conductors, the MVP and voltage determine the total current. Expressed as equations, the connection is:

$$\vec{J} = -\sigma \frac{\partial \vec{A}}{\partial t} - \sigma \nabla \frac{\partial V}{\partial t}, \quad (3)$$

$$i(t) = -\int_S \sigma \frac{\partial \vec{A}}{\partial t} \cdot d\vec{S} + \int_S \frac{\sigma}{L_C} \Delta V d\vec{S}, \quad (4)$$

where L_C – the conductor length, ΔV – the voltage drop.

The ANSYS/Emag program achieves coupling via two additional degrees of freedom to circuit component and FEA conductor elements. The characteristics of these DOFs are as follows: *CURR* – the current flowing through the circuit and the modeled conductor, *EMF* – the voltage drop across the modeled conductor (2-D stranded, 2-D massive, and 3-D stranded conductors), *VOLT* – the electric potential in a 3-D massive conductor

Modeling non-linear circuits with CIRCUI25 element

Element *CIRCUI25* [1-3] can be used to model common (*KEYOPT*(1)=0) and Zener (*KEYOPT*(1)=2) diodes. At any diode state, the piece-wise linear characterization of the diode I-U curve corresponds to a Norton equivalent circuit with a dynamic resistance (i.e. inverse of the slope at the operating point) and a current generator (where the tangent of the I-U curve intersects the I-axis). The element voltage drop, current, and Joule loss computed data provided in the element miscellaneous records may be loaded with some cancellation error if the voltage drop is

much smaller than the nominal voltage level typical for the diode (especially ideal) open state.

CIRCU125 is a diode element normally used in electric circuit analysis. The element may also interface with the electric circuit element *CIRCU124* and mechanical finite elements to simulate fully coupled electromechanical analyses at the lumped parameter level. The element has 2 nodes to define the circuit component and one degree of freedom per node to model the circuit response. *CIRCU125* is applicable to static analyses and transient analyses with restart.

The diode element is defined by the *KEYOPT(1)* setting and its corresponding real constants (Table 4). Real constant input is dependent on the diode option used. The element is characterized by one degree of freedom, *VOLT* (voltage).

Table 4. *CIRCU125* real constants

Diode	Real Constant	Name	Description
D, Z	1	GOFST	Graphical offset
D, Z	2	ID	Element identification number
D, Z	3	-	Blank
D, Z	4	RESF	Forward resistance
D, Z	5	VOLTF	Forward voltage
D, Z	6	RESB	Blocking resistance
Z	7	RESZ	Zener resistance
Z	8	VOLTZ	Zener voltage

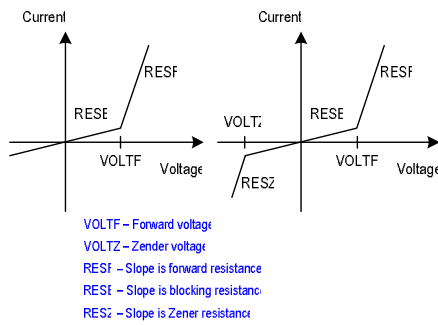

Fig. 5. *CIRCU125* I-U characteristics

The I-U characteristics of the diodes are approximated by the piecewise linear functions shown in Figure 5. The characteristic of a common diode consists of line segments corresponding to the closed and open states. The characteristic of a Zener diode consists of three segments corresponding to the Zener, closed, and open states. The diode characteristic can be ideal or lossy depending on the values of the real constants.

Constructing circuit with Circuit Builder

For all circuit analyses, first it is needed to build a circuit model using the finite elements. The preferred method for building the circuit is to use the circuit builder, an interactive builder available in the graphical user interface. The circuit builder performs the tasks listed below: enables to select circuit components and place them at the desired location in the circuit with the help of a mouse; creates a model of the circuit interactively; assigns "real" constants to circuit components and allows to edit them; assigns excitation to independent sources; verifies excitation graphically; provides an interactive connection

to the FEA domain; lets to specify source loads for voltage and current source components.

The circuit builder establishes the element types, real constants, and node and element definitions. It sets up multiple element types, one for each circuit element. The circuit builder writes to the log file all the commands used to create the circuit elements. The GUI offers a special "wire element" option. This option is provided as a convenience tool to connect regions of an electrical circuit with a "wire".

The circuit builder is the most convenient way to construct a circuit. However, it is also possible build a circuit by individually defining each node, element type, element, and real constant [4].

AM modulation circuit modeling

AM modulation circuit could be considered as an example of electric circuit analysis in *ANSYS/Emag* environment. AM oscillation is described by the following equation [6, 7]:

$$\begin{aligned}
 u_{AM} &= U_{\omega} (1 + M \sin \Omega t) \sin \omega_0 t = \\
 &= U_{\omega} \sin \omega_0 t + \frac{U_{\omega}}{2} M \cos(\omega_0 - \Omega)t - \\
 &\quad - \frac{U_{\omega}}{2} M \cos(\omega_0 + \Omega)t, \quad (5)
 \end{aligned}$$

where U_m – carrier amplitude when modulation is not present; M – modulation coefficient ($M = U_{\Omega}/U_{\omega}$), U_{Ω} – amplitude of modulating signal.

Assume we have a carrier with frequency 10 MHz, and modulating signal with frequency 1 MHz. Then theoretical amplitude characteristic of AM signal is illustrated in Fig. 6.

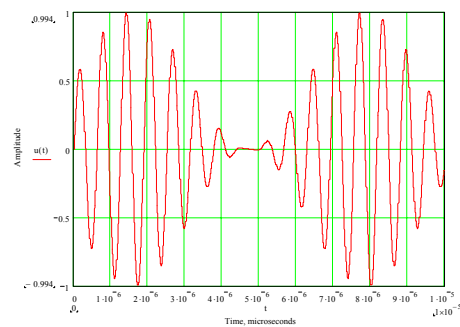

Fig. 6. AM signal, calculated analytically

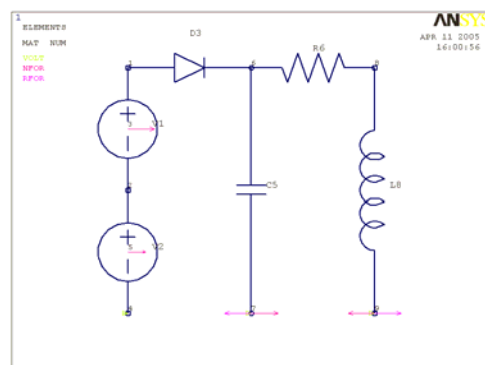

Fig. 7. AM modulator schematics

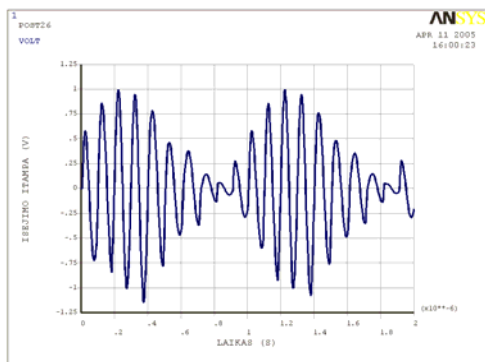

Fig. 8. AM signal modeled in ANSYS

From presented characteristic in Fig. 6, we can see, that AM oscillations can be obtained when multiplying two signals: low frequency Ω signal with amplitude U_{Ω} , and high frequency ω_0 with amplitude U_{ω} . Signals can be multiplied using non-linear element. Schematics of AM modulator, which uses a diode as a non-linear element, is presented in Fig. 7. Parameters of elements are: $f_{V1} = 10\text{MHz}$, $f_{V2} = 1\text{MHz}$, $R_{D3f} = 1\Omega$, $C5 = 1.6\text{pF}$, $R6 = 50\Omega$, $L8 = 0.253\text{mH}$, $U_{V1} = 1\text{V}$, $U_{V2} = 0.5\text{V}$, opening diode voltage $U_{op} = 0.5\text{V}$. Boundary conditions of nodes 4, 8 and 10 are set to 0V (grounded). Resulting modeled signal is shown in Fig. 8.

Conclusions

It is possible to model linear circuits using *CIRCU124* element. These electric circuits consist of components such as resistors, inductors, mutual inductors, capacitors, independent current and voltage sources, and

dependent current and voltage sources. *CIRCU124* is applicable to static, harmonic, and transient analyses. *CIRCU125* element can be used to model non-linear circuits, which consist of common and Zener diodes.

The circuit builder is the most convenient way to construct a circuit. However, it is also possible to build a circuit by individually defining each node, element type, element, and real constants.

Presented circuit modeling example is one of the possible cases of circuit modeling application. However, circuit modeling capabilities in *ANSYS/Emag* environment are quite limited (if comparing with competing products, e.g. *PSPICE*). Advantage is that *ANSYS/Emag* provides functionality of coupling non-linear loads simulated by electric circuit to finite element model. Some signal distortions in modeled circuit may arise due to use of non-linear element, and approximate analytical calculations of circuit element parameters.

References

1. **Theory** Reference: <http://www.ansys.com/>
2. **Electromagnetic** Field Analysis Guide: <http://www.ansys.com/>
3. **ANSYS** Element Reference: <http://www.ansys.com/>
4. **ANSYS** Commands Reference: <http://www.ansys.com/>
5. **Tarvydas P., Markevičius V.** Computation of magnetic fields using a finite element method // *Electronics and Electrical Engineering*. – Kaunas: Technologija, 2000. – No. 1(24). – P. 33–37.
6. **Sveikata J.** Tiesinių grandinių teorija. – Kaunas: Technologija, 2004. – 269 p.
7. **Sveikata J.** Grandinių teorija. – Kaunas: Technologija, 2004. – 109 p.

Pateikta spaudai 2005 04 26

J. Sveikata, P. Tarvydas, A. Noreika. Elektrinių grandinių analizė baigtinių elementų metodu // *Elektronika ir elektrotechnika*. – Kaunas: Technologija, 2005. – Nr. 7(63). – P. 31–34.

Nagrinėjami elektrinių grandinių analizės baigtinių elementų metodu klausimai. Analizuojamos programoje *ANSYS/Emag* realizuoto grafinio redaktoriaus, skirto elektrinėms grandinėms sudaryti, galimybės. Pateikiamos baigtinių elementų *CIRCU124* ir *CIRCU125*, naudojamų įvairių radioelementų ir srovės bei įtampos šaltiniams modeliuoti, charakteristikos. Pateikiamas elektrinės grandinės modeliavimo pavyzdys – AM moduliatoriaus modeliavimas. Modeliavimas susideda iš dviejų etapų: pirmiausia signalo charakteristika apskaičiuojama pagal analitinę jo išraišką, o vėliau tas pats signalas modeliuojamas programa *ANSYS/Emag*. Il. 8, bibl. 7 (anglų kalba; santraukos lietuvių, anglų ir rusų k.).

J. Sveikata, P. Tarvydas, A. Noreika. Electric Circuit Analysis using Finite Element Modeling // *Electronics and Electrical Engineering*. – Kaunas: Technologija, 2005. – No. 7(63). – P. 31–34.

Problem of electric circuit modeling by finite element modeling is investigated. Possibilities of application of graphical redactor implemented in *ANSYS/Emag* environment and intended to form electric circuits are analyzed. Characteristics of finite elements *CIRCU124* and *CIRCU125*, which are used to model various electronics elements and current and voltage sources, are presented in this paper. Example of electric circuit modeling is presented, in which AM modulator modeling is performed. Modeling consists of two stages – first, signal characteristic is calculated using its analytical expression, and later the same signal is modeled in *ANSYS/Emag* environment. Ill. 8, bibl. 7 (in English; summaries in Lithuanian, English and Russian).

Ю. Свейката, П. Тарвидас, А. Норейка. Анализ электрических цепей методом конечных элементов // *Электроника и электротехника*. Каунас: Технология, 2005. – № 7(63). – С. 31–34.

Изучаются вопросы анализа электрических цепей методом конечных элементов. Анализируется способы применения графического редактора, реализованного в программе *ANSYS/Emag*, который предназначен для создания электрических цепей. Представлены характеристики конечных элементов *CIRCU124* и *CIRCU125*, используемых для моделирования различных радиоэлементов, источников электрического тока и напряжения. Предоставлен пример моделирования электрической цепи, в котором выполнено моделирование AM модулятора. Моделирование состоит из двух частей – во первых характеристика сигнала вычисляется по его аналитическому выражению, а потом сигнал моделируется в среде *ANSYS/Emag*. Ил.8, библи.7 (на английском языке; рефераты на литовском, английском и русском яз.).