

Direct Drive Mathematical Model Design and Verification

A. A. Ahranovich, S. E. Karpovich, V. V. Zharsky, S. M. Avakaw, S. A. Rusetsky

*Department of Mathematics, Belarusian State University of Informatics and Radioelectronics,
Brovki st., 6, 220013 Minsk, Belarus*

Introduction

A variety of mathematical models for direct drive can not give the exact and definite description of drive behavior. The approach to mathematical model constructing and its verification are described. The model which with sufficient accuracy describes direct drive is based on model building of physical processes which take place in electrical drive. Mathematical model presented is used for computer simulation of control system with different regulators which are to improve motor's dynamics, and, as the result, hardware performance and precision.

Direct Drive Mathematical Model

The model which with sufficient accuracy describes linear step motor is based on model building of physical processes of linear step motor. Such approach allows to take into consideration most of non-linear energy transformations in the motor.

The presented mathematical model is based on description of physical processes in linear step motor (LSM). Such approach allows take into consideration most non-linear energy transformation in the motor. The model of LSM consists of three parts: electrical, magnetic, and mechanical [1]. Such division of LSM model helps simplify the investigation of model adequacy, besides usage of such approach is supposed to make the model "transparent", e.g. it will help to estimate the contribution of this or that variable into dynamics of LSM.

Electrical model. Control system of direct drive is equipped with power amplifier. Most modern power amplifiers have internal current feedback, so by such means power amplifier can be considered as current source. So, to sum it up, the mathematical model of power amplifier is considered as a current source.

While carrying out computer simulation, eddy currents were neglected [2]. The constant magnet was considered as magnetic flux source with magnetomotive force M_{pm} and magnetic reluctance R_{pm} .

The definition of magnetic reluctances R_i and R_{pl} is the main problem in direct drive dynamics computer simulation.

The problem is that R_i has a non-linear functional dependence on position, air-gap, and flux [2]. For successful computer simulation of direct drive dynamics, it is mandatory to precisely define magnetic reluctances. For the purposes of R_i definition, the magnetic path of electromagnetic module is divided into several parts, which have equal cross-section and magnetic flux density.

The magnetic path is divided into the following parts: core base, legs, drive teeth, air-gap, platform teeth, and platform base.

Having described magnetic reluctance of these parts, it is possible to build magnetic model of drive which describe electromagnetic energy transformation.

The equation for drive force is as follows (1) [3]:

$$F = R_{G0} \frac{4\pi k_G}{p} \left(\Phi_{23} \Phi_{pm,A} \cos \frac{2\pi x}{p} - \Phi_{67} \Phi_{pm,B} \sin \frac{2\pi x}{p} \right), (1)$$

where R_{G0} is average airgap reluctance, k_G is normalized airgap reluctance amplitude, p is pitch, Φ_{23} and Φ_{67} are total fluxes flowing through the electric coil of phases A and B respectively, $\Phi_{pm,A}$ and $\Phi_{pm,B}$ are fluxes flowing through permanent magnet of phases A and B respectively, x is motor coordinate.

The equation (1) presents force F as a function of Φ_i and x .

Mechanical model. While traveling, the linear stepper motor slides over air-cushion support. So, neglecting aerodynamic friction, Newton's law for linear stepper motor can be presented as (2):

$$F - F_d - m\ddot{x} = 0, (2)$$

where m is the total drive mass, F_d is resistance to motion. After double integrating this equation, we find out the interconnection between motor's position x and electromagnetic sub-system of motor.

State space mathematical model

The usefulness of state space model presentation is determined by uniqueness and completeness of motor description with state space equations. This also prepares the

implementation of the model in the computer software used for simulation. Basing on equations which were shown above, we can derive the system of differential equations in state space form which represents the dynamics of the direct drive (3). On the base of these equations, one can mention that variables Φ_{23} , Φ_{67} , x and v are state space variables of direct drive. While the number of states is unique for each system, it should be emphasized that the choice of variables that are declared as state variables is rather a matter of convenience [1]. Using these equations, it is possible carry out computer simulation of direct drive. The inputs of the system are power amplifier currents i_A and i_B . The outputs which are to be monitored depends entirely on the application. In case presented x , v and F are output variables.

For a unique solution of (3), the states at start time must be known.

While carrying out computer simulation of direct drive, it was assumed that power has been switched on a long time ago, so that the power-up transients have subsided. A numerical solution of system of differential equations is used

$$\begin{cases} \dot{\Phi}_{23} = f_1(\Phi_{23}, R_i(x, \Phi_i(i_A(\Phi_{23}, R_j(\dots)), R_k(\dots))), i_A, t) = \\ \quad = \tilde{f}_1(\Phi_{23}, x, i_A, t), \\ \dot{\Phi}_{67} = f_1(\Phi_{67}, R_i(x, \Phi_i(i_A(\Phi_{67}, R_j(\dots)), R_k(\dots))), i_B, t) = \\ \quad = \tilde{f}_1(\Phi_{67}, x, i_B, t), \\ \dot{v} = f_3(F(\Phi_{23}, \Phi_{67}, \Phi_{pm.A}(\Phi_i(i_A(\Phi_{23}, R_j(x, \Phi_j(\dots))), R_k(\dots))), \\ \quad \Phi_{pm.B}(\Phi_i(i_B(\Phi_{67}, R_j(x, \Phi_j(\dots))), R_k(\dots))), F_d(v), t) = \\ \quad = \tilde{f}_3(\Phi_{23}, \Phi_{67}, x, t), \\ \dot{x} = v = \tilde{f}_4(v, t). \end{cases} \quad (3)$$

Simulation software

Almost any language programming language can be used to give a numerical approximation of a system of first order differential equations. Anyway, MATLAB/Simulink software package was used for computer simulation of mathematical model of direct drive. It features a graphical interface for constructing models in a block-diagram-like fashion, offers access to the MATLAB tools for displaying and analyzing produces output. In fact, it has the capability to describe the linear motor model without using differential equations at all, the immediate relations between system variables can be encoded and linked by data flow paths.

Mathematical Model Verification

The main goal of working out a model is to create an adequate model, as only adequacy can guarantee the motor's behavior prediction. To verify worked out model, Identification Toolbox of MATLAB was used. This tool helps verify mathematical model with high accuracy. During experiments, the model of motor LSM-211PF.HS produced by RuchServoMotor was verified.

Identification Toolbox needs some input and output data which represent control signals and system response. Basing on these data, the transfer function of the system is built, and, using one of identification techniques, the model transfer function is constructed. The signals used for model verification are divided into two groups: simulation results

and experimental data. It's obvious, that both groups must incorporate the same signals of two (one virtual –model; another one real- linear step motor with controller) systems. The signals acquired for model verification are shown in Fig. 1.

The block-diagram represents the overall structure of direct drive control system. Regulator block is understood as control system algorithm (i.e. PID or other types of regulators). Power amplifier represents all power converters of the system. LSM means direct drive, and feedback sensor is understood as measurement system.

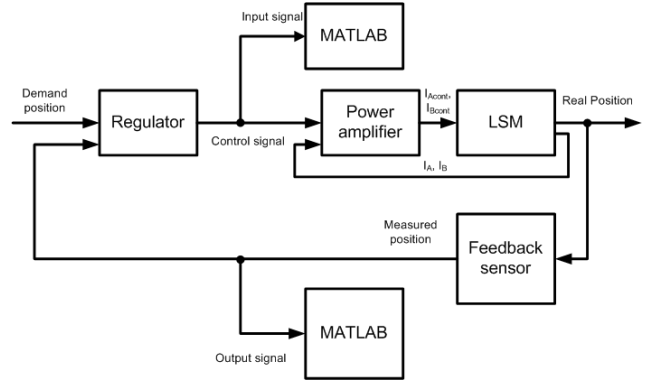

Fig. 1. Signal acquired for model verification

For the case of LSM-PF.211.HS motor verification a hall-effect sensor was used, as this is a standard option of this class of drives.

Experimental investigation

As it was mentioned before, verification procedure presupposes manipulation with experimental data. For the purposes of experimental data acquisition, a test bench was implemented, and direct drive transient process signals were measured and processed.

The signals were measured and processed with different acceleration, velocity and travel tasks, to provide as much as possible information for analysis. The results of experiments, travel errors, with different accelerations (a_{max}) and velocities (V_{max}) are presented in Fig. 2–4.

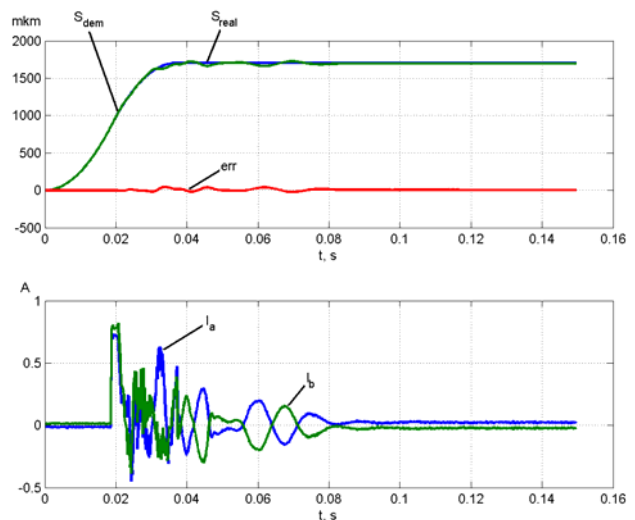

Fig. 2. Transient process signals with $V_{max}=0,1$ m/s, $a_{max}=5$ m/s²

The measurements were carried out using specified equipment on Ruchservomotor enterprise. The measurement system was based on hall effect sensor which is installed in LSM-211PF.HS linear stepper motor.

The control system of drive was based on eZDSP TMS 320 processor by Taxes Instruments.

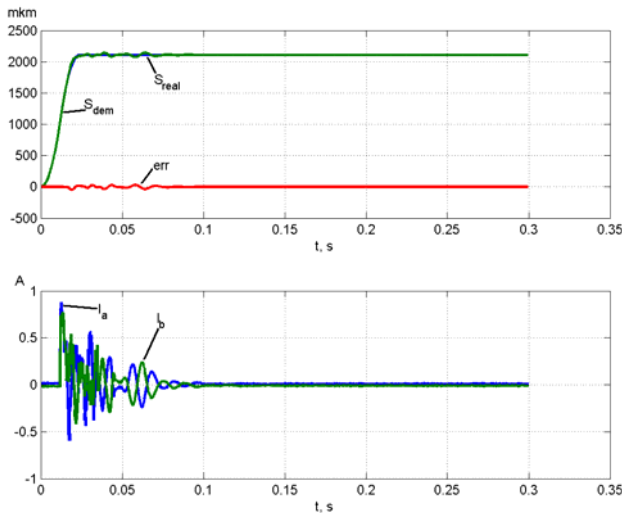

Fig. 3. Transient process signals with $V_{max}=1$ m/s, $a_{max}=15$ m/s²

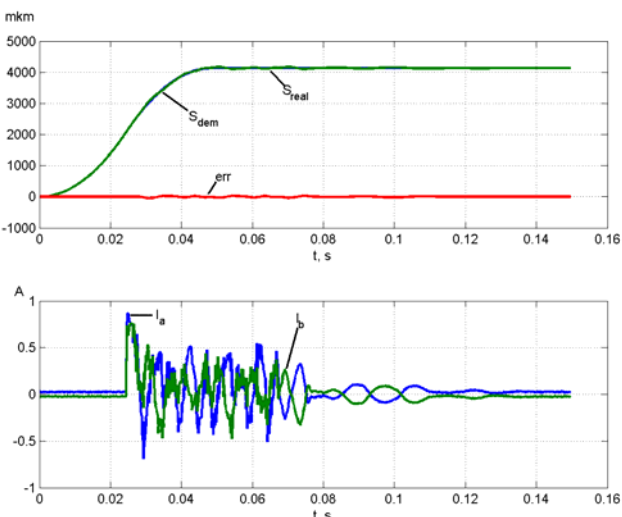

Fig. 4. Transient process signals with $V_{max}=2,5$ m/s, $a_{max}=25$ m/s²

The data was collected in controller and after that transferred to PC for further investigations and analysis.

Verification Algorithm

The experimental data is analyzed in three stages. The first stage incorporates building transfer function of the system on the whole interval of acquired experimental data. The second stage presupposes building two transfer $W_1(s)$ $W_2(s)$ functions of system basing on two different data scopes acquired during the first half time of experiment and during the second one. Having built these three transfer functions, their comparison is carried out. If these transfer functions are similar, the average transfer function $W_{exp}(s)$ is build. In case when these three functions vary greatly, our method of verification can not be applied, as the model changes in time.

The data acquired during computer simulation is also used to build the transfer function of LSM model $W_{mod}(s)$. At last, the comparison of these two transfer functions is done and the conclusion is made. Verification algorithm block-diagram is presented in Fig. 5.

The time scopes of data acquired for verification are presented on Fig. 6.

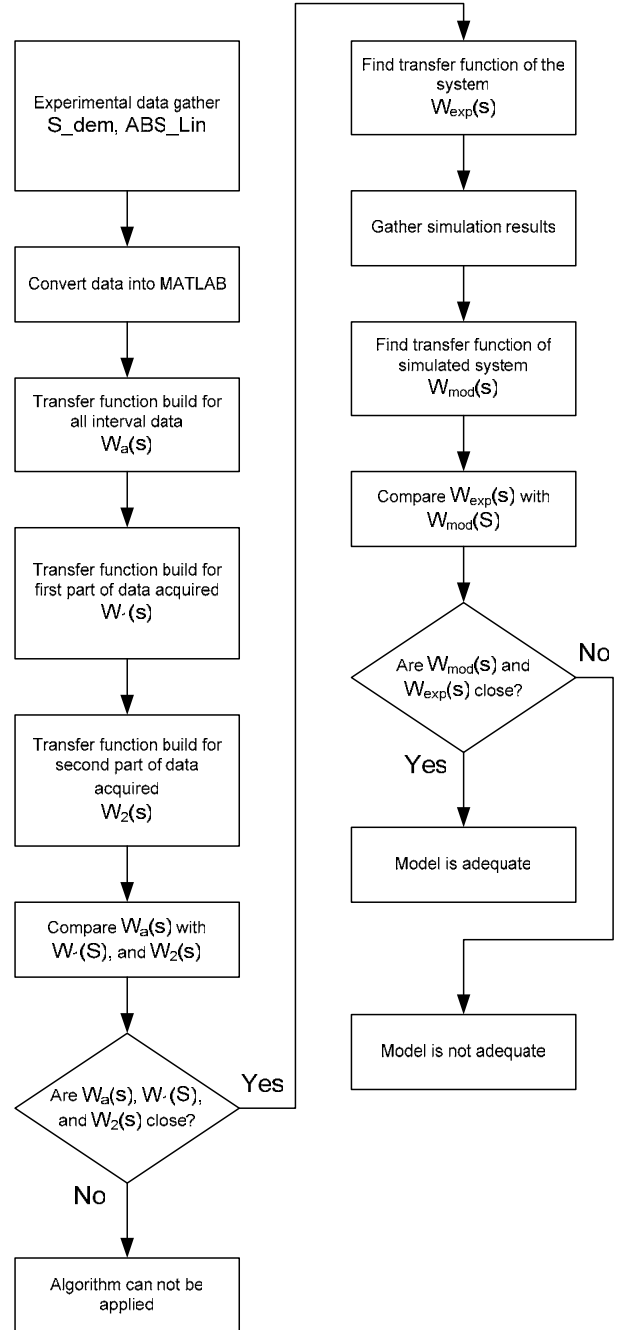

Fig. 5. Verification algorithm block-diagram

Verification Results

On the base of experimental data and data acquired during computer simulation, transfer functions of direct drive were built. The analysis of model adequacy was carried out ARX and PEM methods [6]. Transient responses of model worked out and real direct drive were acquired and compared. These transients are presented in Fig. 7.

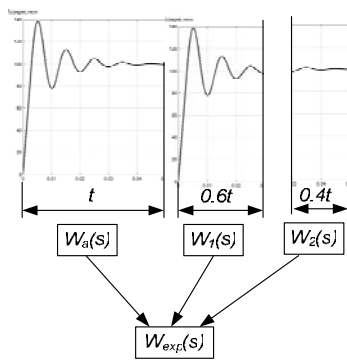

Fig. 6. Verification data scopes

The transfer function of mathematical model is as follows (4):

$$G(s) = \frac{X(s)}{U(s)} = \frac{0.9389s + 0.5411}{s^2 + 0.6211s + 0.5335} \quad (4)$$

While speaking about verification results, one should mention that transfer function which was acquired as the result, shows that direct drive can be represented as a lag element. Though some similar results can be achieved when representing direct drive as a DC-drive, nevertheless, the approach of DC-drive usage is wrong, as the model of direct drive can vary greatly, which depends on different conditions, i.e., speed, currents, etc.

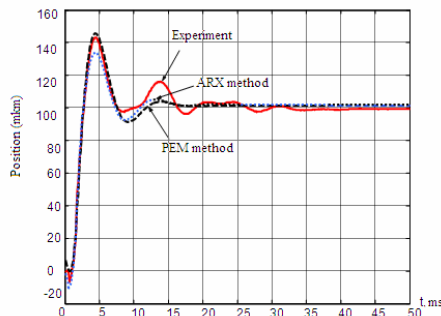

Fig. 7. Verification results

A. A. Ahranovich, S. E. Karpovich, V. V. Zharsky, S. M. Avakaw, S. A. Rusetsky. **Direct Drive Mathematical Model Design and Verification** // *Electronics and Electrical Engineering*. – Kaunas: Technologija, 2007. – No. 5(77). – P. 49–52.

Direct drive mathematical model design and verification procedures and methodology were discussed. The work covers the problems of mathematical model based on state space variables design. While plenty of model design techniques exist, the one which describes the model as a combination of three sub-systems (electrical, magnetic, mechanical) is depicted here. As success of computer simulation of model proposed depends on model's accuracy, verification algorithm is discussed. The obtained high model verification adequacy means that model design method can give good computer simulation results. Ill. 7, bibl. 6 (in English, summaries in English, Russian and Lithuanian).

A. A. Агранович, С. Е. Карпович, В. В. Жарский, С. М. Аваков, С. А. Русецкий. **Разработка и верификация математической модели привода прямого действия** // *Электроника и электротехника*. – Каунас: Технология, 2007. – № 5(77). – С. 49–52.

Рассматриваются вопросы, связанные с разработкой и верификацией компьютерной модели привода прямого действия. Показан метод создания математической модели, основанной на переменных пространства состояний. Математическая модель привода прямого действия рассматривается состоящей из трех подсистем (электрической, магнитной и механической). Так как результаты компьютерного моделирования системы управления в значительной степени зависят от адекватности модели, в работе рассматриваются алгоритмы верификации модели привода прямого действия. Полученные в результате верификации высокие показатели адекватности позволяют судить о достаточно точном представлении модели в системе переменных пространства состояний. Ил. 7, библи. 6 (на английском языке, рефераты на английском, русском и литовском яз.).

A. A. Ahranovich, S. E. Karpovich, V. V. Zharsky, S. M. Avakaw, S. A. Rusetsky. **Tiesioginio valdomo matematinio modelio projektavimas ir verifikacija** // *Elektronika ir elektrotechnika*. – Kaunas: Technologija, 2007. – Nr. 5(77). – P. 49–52.

Aptariamos tiesioginio valdomo matematinio modelio projektavimo ir verifikacijos procedūros bei metodologija. Analizuojamos matematinio modelio projektavimo, paremto būsenos erdvės kintamaisiais, problemos. Nors yra daugybė projektavimo metodų, čia aptariamas metodas nagrinėja modelį kaip trijų posistemių (elektrinio, magnetinio ir mechaninio) kombinaciją. Kadangi modeliavimo sėkmė priklauso nuo modelio tikslumo, aptariamas verifikavimo algoritmas. Gautas didelis verifikavimo adekvatumas rodo, jog pritaikius šį modelio projektavimo metodą galima gauti gerus modeliavimo rezultatus. Il. 7, bibl. 6 (anglų kalba; santraukos anglų, rusų ir lietuvių k.).

Besides that, reducing direct drive mathematical model gives no chance to deep analysis of processes of direct drive which are a great advantage of described approach.

The adequacy of worked-out model with accuracy up to 80...83%. That means that the worked out mathematical model can be used afterwards for computer simulation with different regulators, which increase the motor's dynamic characteristics.

References

1. **Schulze-Lauen H.** Development of an Enhanced Linear Motor Drive for a High Speed Flexible Automation System. – Massachusetts Institute of Technology, 1993.
2. **Mezhinsky Y.** Building Travel Systems for Flexible Automated Equipment. – Minsk: Technoprint, 2002.
3. **RUCH Servomotor.** Web site of the company: www.ruchservomotor.com.
4. **Karpovich S., Dainiak I.** Calibration Algorithm for Control System of Stepping Motor // Proceedings of 45-th International Scientific Colloquium, Ilmenau Technical University (Germany), October 4–6, 2000. – Ilmenau: TU, 2000. – P. 563–567.
5. **Karpovich S., Rusetsky A., Mezhinsky Y.** Dynamics Of Programmed Movements In Multicoordinate Systems // Proceedings of International Conference on Electrical Drives and Power Electronics (EDPE), Koshice, November, 1999. – Koshice: TU, 1999. – P. 215–222.
6. **Ljung L.** System Identification: Theory for the User. – Prentice-Hall, Englewood Cliffs, NJ, 1998. – 150 p.

Submitted for publication 2007 03 05