

Experimental research on eutectic refrigerating system with economizer

L. Vaitkus*, V. Dagilis**

*Kaunas University of Technology, Studentų 56, 51424 Kaunas, Lithuania, E-mail: liutauras.vaitkus@ktu.lt

**Kaunas University of Technology, Studentų 56, 51424 Kaunas, Lithuania, E-mail: vytautas.dagilis@ktu.lt

crossref <http://dx.doi.org/10.5755/j01.mech.23.1.14319>

1. Introduction

The gas refrigerant injection is successfully implemented in refrigerating systems, using the scroll compressors with an additional vapour injection connection. The two main configurations of gas refrigerant injection systems are i) flash tank system and ii) intermediate heat exchanger (IHX) system, also called an economizer technology. The economic system reduces the throttling loss by decreasing the specific enthalpy of the refrigerant, entering the thermostatic expansion valve (TXV) of the main loop. Also, the overheated gas compression loss can be decreased by decreasing the temperature in the compression pocket. Therefore, the gas refrigerant injection improves the performance of the vapor compression system. According to the research Winandy and Lebrun 2002 [1], Wang et al. 2009 [2] under the large compression ratio conditions the gas refrigerant injection not only increase the efficiency and capacity of the system, but also improves system's reliability by decreasing the discharge temperature of compressor.

The previous research on the gas refrigerant injection into the scroll compressors analyse various aspects of the technology. The works as (Winandy and Lebrun, 2002 [1]; Ayub et al., 1992 [3]; Dutta et al., 2001 [4]; Yamazaki et al., 2002 [5]; Park et al., 2002 [6]; Cho et al., 2003 [7]), Tello Oquendo et al., 2016 [8], Navarro et al., 2013 [9], Dardenne et al., 2015 [10] focus on the effects of gas injection on the compressor and reveal the effects of the injection parameters on the compressor power consumption, discharge temperature, compressor efficiency and so on.

The second group mainly focuses on experimental research on the systems with gas injection (Zehnder et al., 2002 [11]; Ma et al., 2003 [12], He et al., 2015 [13], Roh et al., 2014 [14]). These researches show the influence of the gas injection on the performance of the whole system and demonstrate the potential of gas injection technology.

The works of the third group are dedicated to the optimization of the gas-injected system. Ma and Li, 2007 [15] investigated the effect of the injection pressure on an injected heat pump system with an IHX and proposed an optimal injection pressure range for their system. Beeton and Pham, 2003 [16] analyses the impact of the gas injection and offered an economical selection method for the IHX. Wang et al. 2009 [17] developed a model of the refrigeration system with a gas-injected scroll compressor and proposed a set of general principles for the design and operation of the system with a gas-injected scroll compressor. Mathison et al., 2014 [18] investigates the ability of an economized cycle with a saturated vapor injection through a finite number of ports to approach the limiting cycle performance. Redón et al., 2014 [19] analysed the influence of

design parameters, such as the displacement ratio, and optimized these parameters in terms of the COP in ideal conditions.

The objective of this research is the development of high efficiency, low-temperature transport refrigerating system with eutectic plate evaporator. These systems operate at specific operating conditions, such as: i) strict weight limitations, ii) single stage refrigerating system and iii) very low evaporation temperature and high compression ratio. According to [8], for pressure ratios above 7.5 the two-stage reciprocating compressor would offer higher efficiency comparing to the scroll compressor with vapor injection. However, for the transport applications the scroll compressor with economizer is preferable due to weight limitations.

Usually the performance of refrigerating system with economizer can be predicted and parameters of required components can be determined using the selection software provided by compressors manufacturer. However, in the analysed case the vapour injection optimized compressor of the required capacity does not exist and the only available option is to use the compressors, optimized for the liquid injection. In addition to that, the evaporation temperatures in the eutectic system are so low, that even the compressors optimized for liquid injection are operating beyond the limits of the envelope.

The research plan was to design and build an eutectic system with vapour injection and economizer. The tests of the system are developed to help determining the most effective setup of the economizer as well as other required components (compressors, control system...). The tests must also determine the operating parameters of new systems, such as pull-down time and energy consumption.

2. The initial system – low-temperature transport refrigerator

Such refrigerating systems are used in refrigerated bodies for delivery vans. The usual transport refrigerators are used to deliver frozen goods from a single load point to a single destination point or small number of destination points. The refrigerating compressor is constantly running either from the car's engine or from the autonomous engine. Usually such a system is equipped with copper tube – aluminium fin evaporator with forced air convection. The delivery vans analysed in this research are used for the retail distribution of frozen food and have an operation pattern different from other transport refrigerators. The frozen goods are delivered from a single load point, but the number of destination points may reach 30 or even higher. During the unload period the car's engine must be stopped and the door opening causes significant heat load. The distance between the unloading points is usually small and the

possible operation time is insufficient for compensation of this heat load. For such specific application the most suitable refrigerating system is so called eutectic system.

Eutectic systems consist of hollow tubes, beams or plates filled with an eutectic solution (phase change material) to store energy and produce a cooling effect whenever necessary to maintain the correct temperature in the refrigerated container. The Eutectic concept is different to conventional refrigeration systems in that a cold source (heat absorption) is provided by phase change material rather than direct expansion of refrigerant gas. The plates or beams that contain the eutectic are charged (frozen down) at night on mains power. Once the plates are frozen they provide reliable cooling for a specific duration of time and ensure very high instantaneous capacity required for compensation of heat load from the door opening.

To keep the indoor air temperature below -18°C , the eutectic mixture with the phase change temperature equal to -33°C is used. During the eutectic mixture crystallization the evaporation temperature is $-43 \div -45^{\circ}\text{C}$. At the end of the pull-down cycle the evaporation temperature goes below -50°C . At the nominal ambient temperature (20°C) the condensing temperature is $26 - 28^{\circ}\text{C}$. However, the refrigerator should also be able performing pull-down at 38°C ambient temperature, when the condensing temperature increases up to 55°C and the refrigerating compressor is operating under very high compression ratio.

The initial system is equipped with direct expansion (DX) evaporator with mechanical thermostatic expansion valve (TXV) as expansion device, high-pressure (HP) liquid receiver and suction - liquid heat exchanger (SLHX). It uses R507A refrigerants and is equipped with scroll compressor with liquid injection through the discharge temperature control (DTC) valve. The crankcase pressure regulator valve (CPRV) is installed in a suction line for controlling the maximum operating pressure.

3. The economizer system

The test system was designed in such a way, that

the same prototype could be used to test various configurations. The targeted pull-down time (with economizer) is identical to the pull-down time of the initial system. The initial system was equipped with the scroll compressor with the theoretical volumetric capacity of $8.03 \text{ m}^3/\text{h}$. The economizer increases the refrigerating capacity, therefore the economizer system was equipped with the significantly smaller scroll compressor with the capacity of $5.92 \text{ m}^3/\text{h}$.

The components of the prototype refrigerating system are illustrated in the Fig. 1. The setup of evaporator is identical to the initial system. On the Fig. 1 only single eutectic plate is shown for each branch, but actually the entire evaporator comprises of five eutectic plates, combined into two branches. The system was equipped with aluminium micro-channel condenser with the inner volume of 1.345 l . The high-pressure receiver with 4.6 l inner volume is the same as used in the initial system.

The mechanical TXV was used as an expansion device of economizer branch. In the economizer system the main thermostatic expansion valves (TXV) with the maximum operating pressure (MOP) function were used. The TXV with the MOP function allow significant reduction of refrigerant charge as demonstrated by Vaitkus and Dagilis, 2014 [20]. The crankcase pressure regulator valve (CPRV) with 1.7 bar settings.

As the economizer we used plate evaporator certified for refrigerating systems, comprising of 28 stainless steel plates with the dimensions $208 \times 77 \text{ mm}$. The rated capacity of the evaporator is 2 kW at 4.5 K logarithmic mean temperature difference.

The economizer system also comprises of four additional heat exchangers (HX). The purpose of the feed line subcooler (FLSC) of economizer *13* is to subcool liquid before the TXV of economizer while superheating vapour in the suction line. The counter flow liquid - vapour heat exchangers *14* and *15* subcool liquid refrigerant in the main branch of refrigerating system while superheating vapour in a suction line of the compressor. The vapour superheater of the economizer *12* superheats the vapour after economizer while subcooling liquid before the eco-

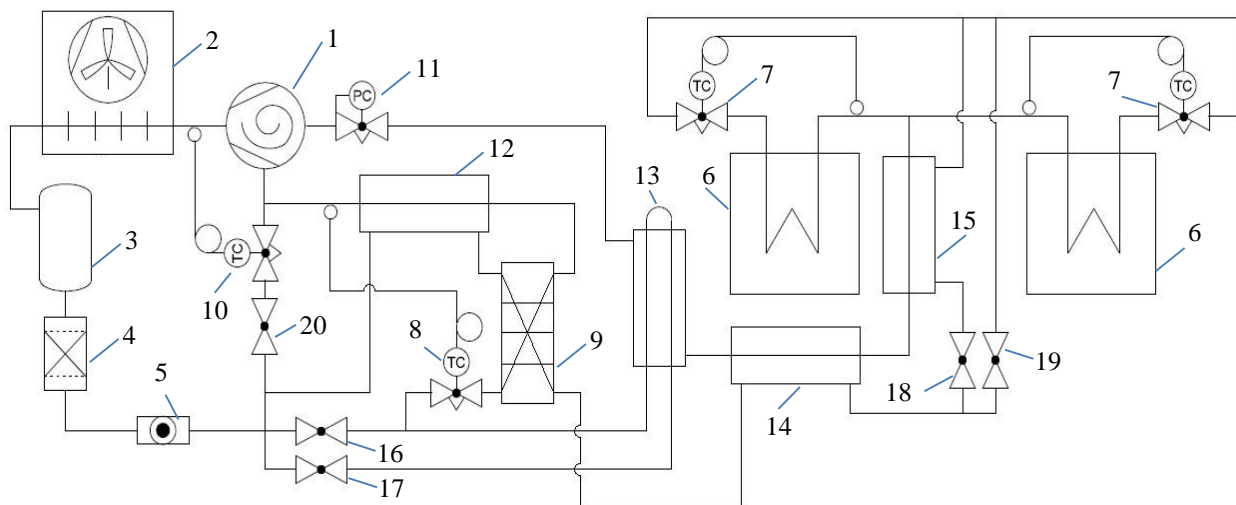

Fig. 1 The test system: 1 – compressor; 2 – condenser; 3 – receiver; 4 – filter; 5 – sight glass; 6 – eutectic plates; 7 – main thermostatic expansion valve (TXV); 8 – TXV of economizer; 9 – economizer; 10 – the discharge temperature control valve; 11 – crankcase pressure regulator valve; 12 – the vapour superheater; 13 – feed line subcooler; 14 – suction-liquid heat exchanger (SLHX) of 1300 mm length; 15 – SLHX of 1700 mm length; 16-20 – shut-off valves

nomizer. This should decrease the heat transfer area of economizer dedicated for vapour superheating.

The economizer system is equipped with five additional valves, which allows testing and comparing performance of different refrigerating system configurations. The system can be tested with economizer (valves *16* or *17* opened) or without it (both *16* and *17* closed). Since in both cases (operating with and without economizer) the refrigerated body, system components and adjustments of TXV and OPR are identical, these tests offer good evaluation of economizer's influence.

The liquid feed to economize can be high temperature liquid after condenser (valve *16* opened, *17* closed) or subcooled liquid after the subcooler *13* (valve *16* closed, *17* opened). The discharge temperature control (DTC) valve can be connected (valve *20* opened) or disconnected (valve *20* closed). When the system is tested without economizer, the DTC valve must be connected to protect the compressor from overheating. When the economizer is connected, the low temperature vapour is injected into the compressor, allowing some protection from overheating.

The system can be tested with the 1700 mm length, suction-liquid heat exchanger *15* disconnected (valve *18* closed, *19* opened); in such a case only the 1300 mm length, suction-liquid heat exchanger *14* is active. Therefore the total length of suction – liquid heat exchanger may be 1300 mm or 3000 mm.

Theoretically the total number of different system configurations is *16*, but not all configurations were tested. For example, the system without economizer should not be tested without the DTC valve because of the compressor's overheating and there is no need in subcooling the liquid before the inactive economizer.

4. Test equipment and methods

During the tests, the Iotech Personal Daq/56 Data acquisition module was used with the acquisition speed set to 610 ms per measurements and the scan period 30 s. Also the K-type thermocouples (accuracy $\pm 1.2^{\circ}\text{C}$, including cold-junction compensation error $\pm 0.5^{\circ}\text{C}$) and Danfoss AKS 32 pressure transmitters (accuracy $\pm 0.8\%$ max, $\pm 3\%$ typical) were used for temperature and pressure measurements respectively. A power consumption was measured with an electrical energy meter ABB OD 4165 (pulse output frequency 100 imp/kWh, Class 2).

The main parameters used for performance evaluation are ambient temperature, inside air temperature, suction temperature, condensing pressure, suction pressure and power consumption. Ambient temperature is average of four air temperatures. Inside air temperature is average of five air temperatures (10 cm below the eutectic plates and 10 cm above the floor in front and rear sections, as well as in the middle of central section). All the air temperatures were measured inside aluminium cylinders. Suction temperature was measured on the outer surface of the suction tube ~ 30 cm from the compressor. Condensing and suction pressures were used to calculate corresponding temperatures (max error of temperature estimation is 0.3 K for condensing and 0.2 K for evaporation).

When comparing performance of refrigerating systems the usual approach is to make the tests under steady conditions. Such an approach is of a limited use for refrigerators with eutectic systems due to the phase change.

The performance of eutectic systems is estimated on transient mode of operation and the main test is temperature pull-down test. During this test, the warm refrigerator with all temperatures equal to ambient temperature is turned on and runs until the cut-out temperature of the thermostat (air, -36°C) is reached. Since the refrigerator is defrosted before each test, the identical heat transfer conditions in evaporator are ensured. The interval of pull-down test during which the inside air temperature decreases from -20 to -33°C is used as an indication of the everyday performance. The pull-down tests were performed in a wide range of ambient temperatures – from $\sim 15^{\circ}\text{C}$ to $\sim 32^{\circ}\text{C}$.

Another important test is the temperature holdover test. After stable on/off cycling conditions are reached, the refrigerating system is turned off and the rise of inside air temperature is registered. The temperature rising time from -33 to -20°C depends on the cold, accumulated in the eutectic plates during the pull-down. Due to the particularity of this test it serves as an indication of the cold accumulated in eutectic plates and efficiency of insulation, rather than efficiency of refrigerating system itself.

The eutectic plates used in the economizer system were identical to the plates of the initial system. The amount of accumulated cold during the holdover test must also be identical and the difference in holdover time should be an indication of differences in the quality of insulation and external heat transfer. The quality of insulation of the economizer system was lower compared to the average initial system – the heat transfer rate was $\sim 6\%$ higher.

5. Test results

The objective of the first stage of the research was to compare performance of the modified system running without economiser to the performance of the initial system. The summarised results of these tests are presented on the Fig. 2 and Fig. 3. At 20°C ambient temperature the measured pull-down time of the modified system increased by $\sim 30\%$. The main factor causing the increase is lower refrigerating capacity of prototype compressor. According to the manufacturer's data, the refrigerating capacity of the initial system's compressor is higher by 38% when compared to the modified system's compressor.

The deeper comparison between the expectations and measurements is difficult because of the concurrent additional factors. Due to the lower refrigerating capacity of the modified system compressor, the thermal loads and temperature differences in condenser and evaporator decreases, increasing evaporation pressure and efficiency. The mass flow rate of this system is also lower, which decreases the hydraulic losses and further increases the suction pressure and efficiency. However, the heat transfer through the insulation of the modified system also increases due to longer pull-down, which increases pull-down energy consumption. Finally, the performance of the modified system is compared to available measurements (pull-down time and energy consumption) of the initial system, but differences of the insulation quality could not be accurately compared since the insulation quality was not measured for every tested initial system system. The heat transfer through the insulation of the modified system is $\sim 6\%$ higher when compared to the average value of the initial system calculated from the available scope of measurements. The compressor with the capacity of $5.92\text{ m}^3/\text{h}$

without economizer is not capable to ensure the required pull-down time, but the efficiency of both systems is very close – the positive and negative factors to efficiency does mutually compensate.

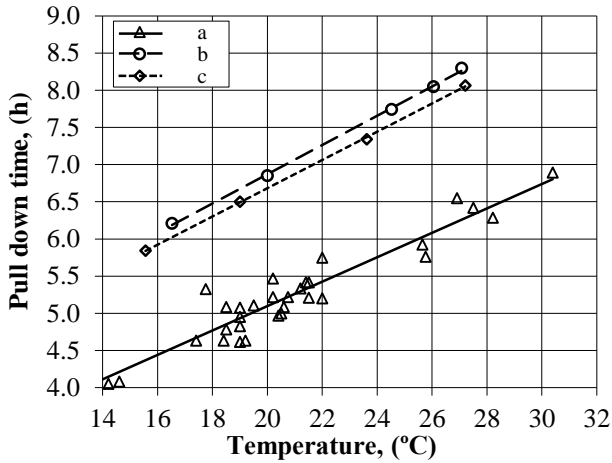

Fig. 2 The pull-down time, subject to ambient temperature for the pull-down from -20 to -33°C ; a - the initial system; b - the modified system without economizer with SLHX 1300 mm; c - the modified system without economizer with SLHX 3000 mm

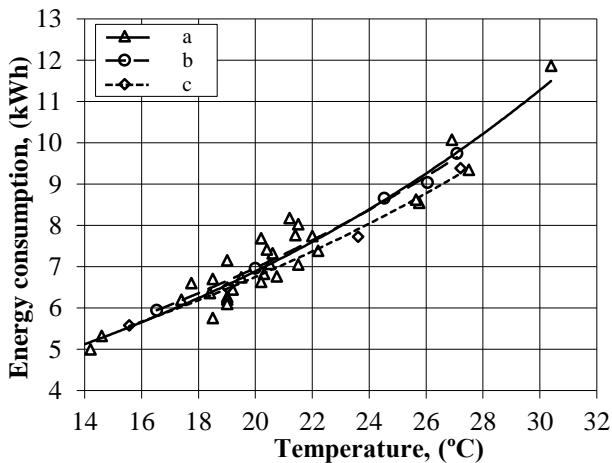

Fig. 3 The energy consumption, subject to ambient temperature for the pull-down from -20 to -33°C ; a - the initial system; b - the modified system without economizer with SLHX 1300 mm; c - the modified system without economizer with SLHX 3000 mm

The next stage of research was the testing of the modified system with the economizer equipped with the plate intermediate heat exchanger. The system was tested with the suction-liquid heat exchangers with the lengths of 1300 mm and 3000 mm; the feed line subcooler was enabled or disabled. The test results are compared with the performance of the initial system as well as to the same modified system operating with disabled economizer. The variation of some distinctive temperatures during the pull-down for the modified system with enabled and disabled economizer is presented on the Fig. 4 and Fig. 5 respectively. Since both tests are performed on the same modified system, the uncertainty due parameters of system components (compressors, evaporators, insulation, etc.) are eliminated and the performance difference can be attributed to the effect of the economizer.

During crystallization of eutectic plates the intermediate evaporation temperature in the economizer was $\sim -12^{\circ}\text{C}$ and the temperature difference at the exit of economizer was $\sim 2\text{ K}$. The recommended intermediate evaporation temperature for the vapour injection optimized compressor at similar operating conditions would be $\sim -24^{\circ}\text{C}$ - significantly lower than observed in the prototype. The recommended liquid temperature after the economizer would be -19°C comparing to -10°C in our modified system. Obviously the compressor designed for liquid injection cannot ensure the same economizers capacity as the compressor optimized for vapour injection. However, if vapour injection optimized compressor of required capacity is not available, the economizer can still be used and will ensure significant liquid subcooling. In the analysed case the liquid subcooling achieved in the economizer makes $\sim 80\%$ of the recommended subcooling in the economizer of vapour injection optimized compressor.

When manufacturers data for the vapour-injection-optimized compressor with the economizer of recommended size is compared with the data of the liquid-injection-optimized compressor with SLHX as in the initial system, the COP increase should be 13% and capacity increase – 38%. The subcooling in economizer of the modified system was lower than recommended subcooling for the vapour-injection-optimized system, therefore the expected performance improvement of the compressor in the prototype is lower as well. However, some of observed performance improvement is caused by other factors, such as dynamic effects, changes to heat transfer conditions, etc.

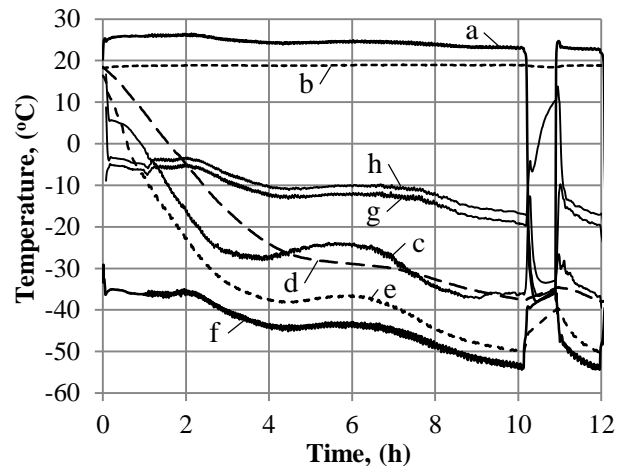

Fig. 4 The variation of temperatures during the pull-down of the modified system with economizer, feed line subcooler disabled, suction-liquid heat exchanger of 3000 mm length at 18.9°C ambient temp.; a - condensing; b - ambient air; c - liquid refrigerant before main TXV; d - average inner air; e - average plate; f - evaporation; g - evaporation intermediate; h - liquid out of economizer

One of such dynamic effects can be observed when analysing the pull-down from -20°C to -33°C (the Fig. 4 and Fig. 5). When economizer is enabled the average evaporation temperature is approximately -44.5°C , but with disabled economizer this temperature decreases to -46.6°C . When economizer is enabled, the pull-down from -20 to -33°C is mainly coinciding with the crystallization period; without the economizer the pull-down period is

moved to a lower evaporation temperature. Regardless of the lower refrigerating capacity, the average evaporation temperature decreases by more than 2 K when economizer is disabled. Such decrease in evaporation temperature should cause ~8% efficiency decrease.

The performance of the modified system with the plate economizer and the performance of the initial system is summarized on the Fig. 6 and Fig. 7. The significant increase of refrigerating capacity was observed with enabled economizer. At 20°C ambient temperature the pull-down time decreased by 26-27%, when compared to the tests of the prototype with disabled economizer and with the SLHX of 1300 mm length. The 5.92 m³/h capacity compressor with economizer demonstrates the same pull-down time as 8.03 m³/h capacity compressor in the initial system. One more interesting feature of the systems with economizer – these systems are less sensitive to high ambient temperature. While the ambient temperature increases from 20 to 30°C, the pull-down time of the initial system increases by 31%, but for the modified system with the economizer this increase is just 22%. At 30°C ambient temperature the pull-down time of the initial system is higher by ~14.5%. The system with economizer offers the highest capacity when it is needed.

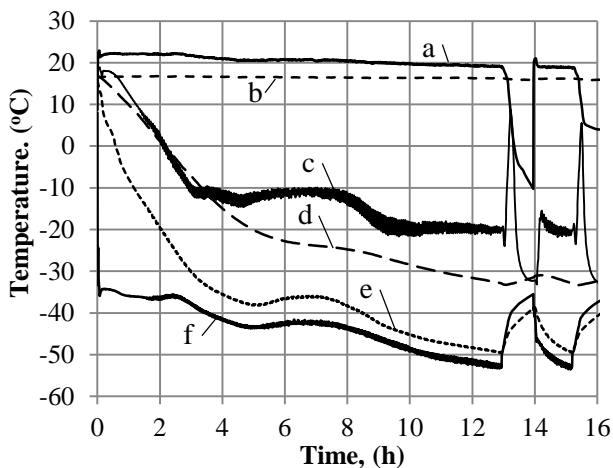

Fig. 5 The variation of temperatures during the pull-down of the modified system with disabled economizer, suction-liquid heat exchanger of 300 mm length at 16.5°C ambient temp.; a - condensing; b - ambient air; c - liquid refrigerant before main TXV; d - average inner air; e - average plate; f - evaporation

The economizer also offers the significant efficiency improvement comparing to the initial system over the whole ambient temperature range. During the pull-down at the 20°C ambient temperature the energy consumption decreased by the respectable 17%, but at 30°C ambient temperature the measured decrease of energy consumption is even higher and reaches 25%. In addition to that, the prototype's quality of insulation was worse by ~6%.

Another important question is the comparison between the different economizer setups. As can be seen from the Fig. 6 and Fig. 7, all the systems offered similar pull-down time and energy efficiency (the difference of observed performance within the error of measurement). The only system with slightly worse performance was the

system with the suction-liquid heat exchanger of 1300 mm length and disabled feed line subcooler. Since performance of all systems was similar, the decision can be based on technological and economic motives.

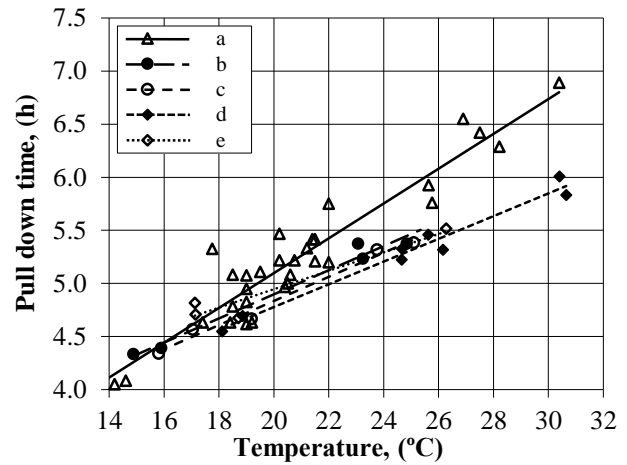

Fig. 6 The pull-down time, subject to ambient temperature for the pull-down from -20 to -33°C; a - the initial system; b - the modified system with plate economizer (PE), feed line subcooler (FLSC) enabled, suction-liquid heat exchanger (SLHX) of 3000 mm length; c - the system with PE, FLSC enabled, SLHX of 1300 mm length; d - the modified system with PE, FLSC disabled, SLHX of 3000 mm length; e - the prototype with PE, FLSC disabled, SLHX of 1300 mm length

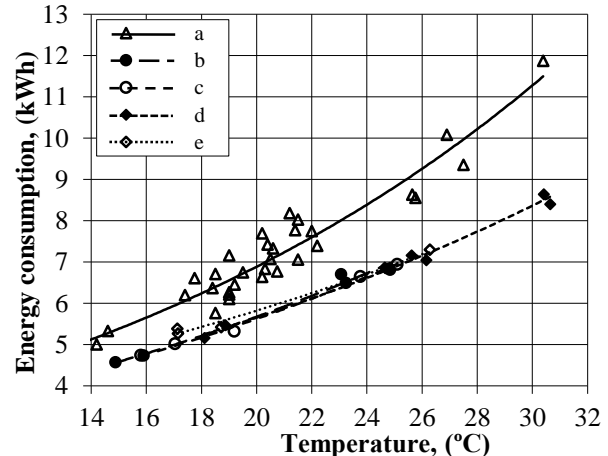

Fig. 7 The energy consumption during the pull-down from -20 to -33°C, subject to ambient temperature; a - the initial system; b - the modified system with plate economizer (PE), feed line subcooler (FLSC) enabled, suction-liquid heat exchanger (SLHX) of 3000 mm length; c - the system with PE, FLSC enabled, SLHX of 1300 mm length; d - the modified system with PE, FLSC disabled, SLHX of 3000 mm length; e - the prototype with PE, FLSC disabled, SLHX of 1300 mm length

The subcooled liquid feeding (SLF) to TXV of economizer offered no positive effect, therefore this component was eliminated for the further development of the modified system. Without FLSC, the vertical section of the suction tube (length 900 mm) can be used for SLHX, instead of being used for subcooler. For the further develop-

ment, we selected the setup with 2200 mm SLHX. The 900 mm option was rejected since 1) in combination without SLF it demonstrated measurably worse performance and 2) 1300 mm section of suction tube still has to be used, which makes the possible cost savings negligible. The 3900 mm SLHX was rejected since a further increase in cost and weight was deemed unjustified.

The holdover tests were performed at a 20°C ambient temperature. Since the design of eutectic plates was not changed, no changes in holdover performance were expected. The holdover time, demonstrated by the prototype at 20°C ambient temperature, is 21.4 hours, against 22.5 hours average holdover of the baseline system. This difference can be explained by the lower quality of the modified system's insulation.

6. The discharge temperature control

One more question considering the eutectic system with an economizer is whether the DTC valve is required. Since relatively low temperature vapour from economizer is injected into compressor through the injection port, the compressor receives some cooling. As we already mentioned, elimination of the DTC valve would simplify the system layout and decrease the cost.

The economizer system with disabled DTC was tested at various ambient temperatures. At a nominal 20°C ambient temperature the vapour injection through the economizer is sufficient and additional cooling through liquid injection is not needed. At a 32°C ambient temperature the different situation was observed. At the initial stage of pull-down and during the crystallization of eutectic plates the system with vapour injection through an economizer demonstrated 94–96°C discharge temperature, which is within allowable temperature limits. However, at the final stage of pull-down (after the crystallization) the discharge temperature of the system with disabled DTC started increasing and reached 106°C before the system was turned OFF by the system thermostat (inside air temperature reached -36°C). The maximal allowable discharge temperature is set by the discharge temperature relay, with the set point of the $99 \pm 3^\circ\text{C}$. This relay was short-circuited for this experiment. The difference may seem insignificant, but in the real life the refrigerator is loaded with the frozen goods and the heat transfer is decreased by the frost accumulation on the eutectic plates. Both these factors increase the difference between the evaporation and air temperatures and in the worst cases the increase exceeds 10 K. The system without the DTC would be turned OFF by the discharge temperature relay far from the air temperature set-point.

As demonstrated previously, the system with economizer performs especially effectively at high ambient temperatures, which could be a strong selling point. However, the system should remain functional at least up to 38°C ambient temperature (subtropical conditions). One possible solution would be to eliminate the discharge temperature relay and leave the temperature uncontrolled. However, at higher ambient temperatures at the final stage of pull-down such system will be overheating, which may decrease the durability of the compressor. Moreover, the system without the DTC relay will be unprotected in case of faulty equipment even at lower ambient temperatures. For example, the malfunction of the TXV of economizer

will cause overheating of the compressor. Therefore, we would recommend installing the DTC valve parallel to economizer branch and keeping the discharge temperature control relay in place. Such setup was successfully tested and no interference between the operation of DTC valve and economizer branch was observed.

7. Cost reduction possibilities

The commercial success of an economizer system strongly depends on the competitive cost. The use of a smaller compressor (5.92 m³/h instead of 8.03 m³/h) offered some cost reduction. However, the cost of the plate economizer is two times higher compared to the saving from the smaller compressor. The additional TXV, insulation, solenoid valve and fittings of economizer also drive the system's cost up. The objective of the next research stage was to estimate the cost reduction possibilities.

All the available plate heat exchangers, certified for the refrigerating equipment, are relatively expensive. The capacity of the plate economizer in the modified system is ~450 W. The value is significantly lower than the nominal capacity of the used plate heat exchanger. Due to the oversized plate heat exchanger the measured temperature difference at its exit was just 2 K. The logarithmic mean temperature difference for the system with disabled feed line subcooler was 12 K.

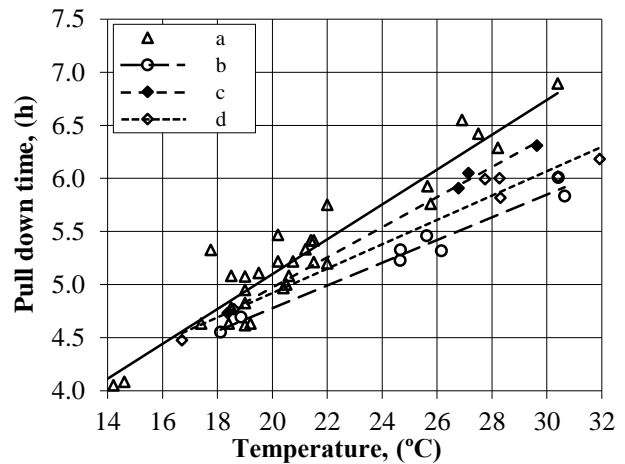

Fig. 8 The pull-down time, subject to ambient temperature for the pull-down from -20 to -33°C; a - the initial system; b - the modified system with plate economizer, feed line subcooler (FLSC) disabled, suction-liquid heat exchanger (SLHX) of 3000 mm length; c - the modified system with tube-in-tube (TIT) economizer, with FLSC enabled, SLHX of 3000 mm length; d - the modified system with TIT economizer, with FLSC disabled, SLHX of 3000 mm length

The proposed heat exchanger was a tube-in-tube counter-flow type. The outer tube was $\text{Ø}12 \times 1$ mm copper tube, the inner tube was $\text{Ø}8 \times 1$ mm copper tube. The liquid after the receiver is flowing through the circular channel, and the evaporating refrigerant – through the inner tube. The equivalent diameter of the circular channel is only 2 mm, which causes significant hydraulic losses (~2.7 kPa). Still, the estimated decrease of liquid subcool-

ing in economizer due to the saturation temperature drop has been just 0.1 K. The hydraulic losses on the low pressure side of economizer increase the final liquid temperature after economizer (the estimated increase is ~ 2 K).

The economizer for the next revision of the modified system was a tube-in-tube (TIT), counter-flow heat exchanger, built of $\text{Ø}12 \times 1$ mm outer tube and $\text{Ø}8 \times 1$ mm inner tube of 2500 mm length, coiled up on the $\text{Ø}150$ mm cylinder. Taking into account the savings from the smaller compressor, it is possible to build the new system with approximately the same cost as initial system.

The test results of the modified system with the TIT economizer are given on the Fig. 8 and Fig. 9. As expected, with the TIT economizer some performance degradation was observed, comparing with the plate economizer. At 20°C and 30°C ambient temperature the pull-down time increased by 3.1% and 3.75% respectively. The corresponding energy consumption increased by 3.1% and 4.8%. Considering the subcooled liquid feeding, the observed results are identical to the previous tests – the liquid subcooling before the TXV of economizer offers no positive effect.

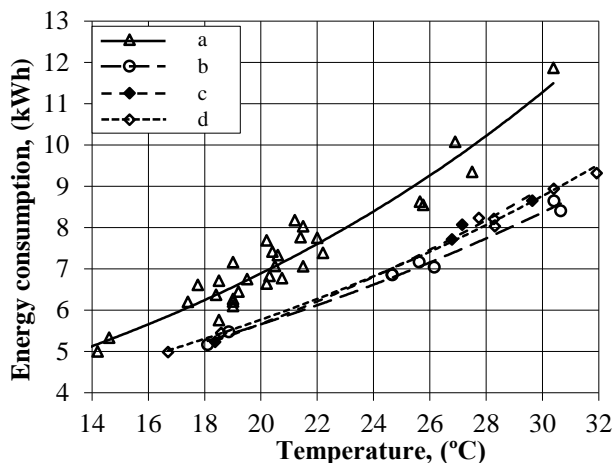

Fig. 9 The energy consumption during the pull-down from -20 to -33°C , subject to ambient temperature; a - the initial system; b - the modified system with plate economizer, feed line subcooler (FLSC) disabled, suction-liquid heat exchanger (SLHX) of 3000 mm length; c - the modified system with tube-in-tube (TIT) economizer, with FLSC enabled, SLHX of 3000 mm length; d - the modified system with TIT economizer, with FLSC disabled, SLHX of 3000 mm length

Comparing the system with TIT heat exchanger of economizer to the initial system, we still see significant advantages. The pull-down energy consumption decreased by 16% at 20°C ambient temperature and by 21% at 30°C ; the pull-down time decreased by 4% and 10% respectively. Since the improvement was achieved without increasing the systems cost, such a product should be also very competitive.

8. Conclusions

The economizer technology traditionally is used with vapour-injected scroll compressors. However, if vapour-injected scroll compressors of required capacity are

not available, the liquid-injected scroll compressors can be used in a system with economizer and still offer performance improvement. The effect is especially noticeable at high compression ratios, i.e. for low evaporation temperatures or high condensing temperatures. Compared to the initial system without economizer, the pull-down energy consumption of the system with the plate economizer decreased by up to 25% at 30°C ambient temperature

When operating at high condensing temperatures and low evaporation temperatures, just the vapour injection through the economizer branch is not sufficient to ensure compressors cooling (the discharge temperature of the compressor increases above 100°C). Therefore the system must be equipped with the additional discharge temperature control valve, connected parallel to economizer branch.

The custom-built tube-in-tube type economizer was developed and tested in order to minimize the cost increase. Compared to the initial system without economizer, the pull-down energy consumption decreased by more than 20% at 30°C ambient temperature.

References

1. **Winandy, E.L.; Lebrun, J.** 2002. Scroll compressors using gas and liquid injection: experimental analysis and modelling, *International Journal of Refrigeration* 25: 1143-1156. [http://dx.doi.org/10.1016/S0140-7007\(02\)00003-8](http://dx.doi.org/10.1016/S0140-7007(02)00003-8).
2. **Wang, B.; Shi, W.; Li, X.** 2009. Numerical analysis on the effects of refrigerant injection on the scroll compressor, *Applied Thermal Engineering* 29(1): 37-46. <http://dx.doi.org/10.1016/j.applthermaleng.2008.01.025>
3. **Ayub, S.; Bush, J.W.; Haller, D.K.** 1992. Liquid refrigerant injection in scroll compressors operating at high compression ratio, *Proceeding of the International Compressor Engineering Conference at Purdue*, 561-567.
4. **Dutta, A.K.; Yanagisawa, T.; Fukuta, M.** 2001. An investigation of the performance of a scroll compressor under liquid refrigerant injection, *International Journal of Refrigeration* 24: 577-587. [http://dx.doi.org/10.1016/S0140-7007\(00\)00041-4](http://dx.doi.org/10.1016/S0140-7007(00)00041-4).
5. **Yamazaki, H.; Itoh, T.; Sato, K.; Kobayashi, H.** 2002. High performance scroll compressor with liquid refrigerant injection, *Proceeding of the International Compressor Engineering Conference at Purdue, USA*, C22-1.
6. **Park, Y.C.; Kim, Y., Cho, H.** 2002. Thermodynamic analysis on the performance of a variable speed scroll compressor with refrigerant injection, *International Journal of Refrigeration* 25: 1072-1082. [http://dx.doi.org/10.1016/S0140-7007\(02\)00007-5](http://dx.doi.org/10.1016/S0140-7007(02)00007-5).
7. **Cho, H.; Chung, J.T.; Kim, Y.** 2003. Influence of liquid refrigerant injection on the performance of an inverter-driven scroll compressor, *International Journal of Refrigeration* 26: 87-94. [http://dx.doi.org/10.1016/S0140-7007\(02\)00017-8](http://dx.doi.org/10.1016/S0140-7007(02)00017-8).
8. **Tello Oquendo, F. M.; Navarro Peris, E.; González Macia J.; Corberán, J.M.** 2016. Performance of a scroll compressor with vapor injection and two-stage reciprocating compressor operating under extreme conditions, *International Journal of Refrigeration* 63: 144-156.

- <http://dx.doi.org/10.1016/j.ijrefrig.2015.10.035>.
9. **Navarro, E.; Redón, A.; González-Macia, J.; Martínez-Galvan, I.O.; Corberán, J.M.** 2013. Characterization of a vapor injection scroll compressor as a function of low, intermediate and high pressures and temperature conditions, *International Journal of Refrigeration* 36(7): 1821-1829.
<http://dx.doi.org/10.1016/j.ijrefrig.2013.04.022>.
 10. **Dardenne, L.; Fraccari, E.; Maggioni, A.; Molinaroli, L.; Proserpio, L.; Winandy, E.** 2015. Semi-empirical modelling of a variable speed scroll compressor with vapour injection, *International Journal of Refrigeration* 54: 76-87.
<http://dx.doi.org/10.1016/j.ijrefrig.2015.03.004>.
 11. **Zehnder, M.; Favrat, D.; Hohl, H.; Olivier, C.; Perevozchikov, M.** 2002. High performance air-water heat pump with extended application range for residential heating, *The Seventh International Energy Agency Conference on Heating Pumping Technologies*, Beijing, China, 19-22.
 12. **Ma, G.; Chai, Q.; Jiang, Y.** 2003. Experimental investigation of air source heat pump for cold regions, *International Journal of Refrigeration* 26: 12-18.
[http://dx.doi.org/10.1016/S0140-7007\(02\)00083-X](http://dx.doi.org/10.1016/S0140-7007(02)00083-X).
 13. **He, Y.; Cao, F.; Jin, L.; Wang, X.; Xing, Z.** 2015. Experimental study on the performance of a vapor injection high temperature heat pump, *International Journal of Refrigeration* 60: 1-8.
<http://dx.doi.org/10.1016/j.ijrefrig.2015.08.012>.
 14. **Roh, Ch.W.; Kim, M.S.** 2014. Effect of vapor-injection technique on the performance of a cascade heat pump water heater, *International Journal of Refrigeration* 38: 168-177.
<http://dx.doi.org/10.1016/j.ijrefrig.2013.09.020>.
 15. **Ma, G.; Li, X.** 2007. Exergetic optimization of a key design parameter in heat pump systems with economizer coupled with scroll compressor, *Energy Conversion and Management* 48: 1150-1159.
<http://dx.doi.org/10.1016/j.enconman.2006.10.007>.
 16. **Beeton, W.L.; Pham, H.M.** 2003. Vapor-injection scroll compressors, *ASHRAE Journal* 45(4): 22-27.
 17. **Wang, B.; Shi, W.; Han, L.; Li, X.** 2009. Optimization of refrigeration system with gas-injected scroll compressor, *International Journal of Refrigeration* 32(7): 1544-1554.
<http://dx.doi.org/10.1016/j.ijrefrig.2009.06.008>.
 18. **Mathison, M.M.; Braun, J.E.; Groll, E.A.** 2014. Approaching the performance limit for economized cycles using simplified cycles, *International Journal of Refrigeration* 45: 64-72.
<http://dx.doi.org/10.1016/j.ijrefrig.2014.05.025>.
 19. **Redón, A.; Navarro-Peris, E.; Pitarch, M.; González-Macia, J.; Corberán, J.M.** 2014. Analysis and optimization of subcritical two-stage vapor injection heat pump systems, *Applied Energy* 124: 231-240.
<http://dx.doi.org/10.1016/j.apenergy.2014.02.066>.
 20. **Vaitkus, L.; Dagilis V.** 2014. Refrigerant charge reduction for low-temperature transport refrigerator with eutectic plate evaporator, *International Journal of Refrigeration* 47: 46-57.
<http://dx.doi.org/10.1016/j.ijrefrig.2014.07.011>.

L. Vaitkus, V. Dagilis

EXPERIMENTAL RESEARCH ON EUTECTIC REFRIGERATING SYSTEM WITH ECONOMIZER

S u m m a r y

In the article a problem of performance improvement of the transport refrigerating system with eutectic plate evaporator is analysed. Due to weight limitations the system is equipped with single-stage compressor, which operates at very low evaporation temperatures. For such conditions the economizer technology offers substantial performance improvement.

A transport refrigerating system with eutectic plate evaporator and economizer is investigated and compared to the eutectic system without economizer. Different configurations of an economizer system with additional suction liquid heat exchangers and with/without additional liquid injection through the discharge temperature control valve are analysed.

Comparing to the initial system, the pull-down energy consumption decreased by more than 20% at 30°C ambient temperature. The proposed design of the economizer heat exchanger allows efficiency improvement without significant cost increase.

Keywords: eutectic refrigerating system, economizer.

Received March 03, 2016

Accepted February 06, 2017