

Monitoring the condition of the cutting tool using self-powering wireless sensor technologies

V. Ostasevicius¹ · V. Jurenas¹ · V. Augutis² · R. Gaidys¹ · R. Cesnavicius¹ ·
L. Kizauskiene³ · R. Dundulis¹

Received: 8 February 2016 / Accepted: 16 May 2016 / Published online: 9 June 2016
© The Author(s) 2016. This article is published with open access at Springerlink.com

Abstract An effective system for monitoring the wear of the machine tool inserts could significantly contribute to saving costs in manufacturing. One of the most recent and popular of effective monitoring methods revolves around the use of sensing technologies for indirect estimation of tool wear. The sensory information is difficult to collect from machine tools due to the extremely poor signal-to-noise ratio of the relevant tool wear-related information because the milling operation is of interrupted nature since the work piece is in contact with the tool edge several times per second. Another issue is the varying thickness of the chip during the penetration of the work piece. Yet, many challenges still impede the practical application of this method for industrial environment. Therefore, the paper presents a method that could solve these challenges especially in industrial environment. The proposed self-powered wireless sensor node is integrated in the structure of the cutting tool. The voltage generated from the cutting tool vibrations of the harvester exponentially rises when the capacitor is fully charged and wireless signal sent to the receiver. As the intensity of energy accumulation depends on the state of the cutting tool wear, it indicates and detects the tool condition. The proposed technique could be useful for the identification of the cutting tool quality and the relative tool-work piece position. The information about the variation of tool

wear is beneficial for helping the manufacturers to control the cutting process, to minimize the product cost as well as to improve the machining quality and efficiency.

Keywords Energy harvesting · Wireless transmission · Surface roughness · Acoustic emission · Tool vibrations

1 Introduction

The dynamics of the cutting process is rather transient, and hence, the cutting conditions play an important role due to the considerable effect they have on the stability of the process. In machining, two categories of monitoring faults can be distinguished, namely faults that occur during the cutting process and the ones developing in the machine tools [1], and they both disrupt the stability in machining or affect the condition of the cutting tool. The impact caused by the direct interaction of work piece material and the cutting tool during machining could be evaluated by applying the acoustic emission (AE) sensor. The signal of vibrations caused during metal cutting is a set of forced, free, periodic, random vibrations [2]. Wear detection and monitoring during operation are complex and difficult tasks, especially for materials under sliding conditions [3]. Techniques functioning on the fast Fourier transform (FFT) or continuous wavelet transform are utilized for feature extraction. The monitoring of the cutting tool state, during machining, by placing an AE sensor, together with a 3D accelerometer, on the shank of the cutting tool holder is presented in the study [4]. In this way, the AE sensor estimates the changes occurring internally, the vibration sensor shows the external change in the state of the tool and the FFT evaluates the output of the sensors. Thus, the experiment carried out in this study suggests that AE and vibration sensors are an

✉ V. Ostasevicius
vytautas.ostasevicius@ktu.lt

¹ Institute of Mechatronics, Kaunas University of Technology, Studentu St. 56-123, LT-51368 Kaunas, Lithuania

² Faculty of Electrical and Electronics Engineering, Kaunas University of Technology, Studentu St. 48-211, LT-51368 Kaunas, Lithuania

³ Faculty of Informatics, Kaunas University of Technology, Studentu St. 48-213, LT-51368 Kaunas, Lithuania

effective means to observe the state of the tool and various other occurrences during the cutting process.

The wear of the cutting tool has an impact on its surface quality, life span and production time [5]; therefore, an online system, for the measurement and monitoring of the tool wear, through the application of a low-cost sensor, was developed. System identifies and analyses the signals of the deflection of the tool holder due to the cutting force, estimates the resulting wear of the tool and displays the results on the screen. Furthermore, article [6] deals with experimental testing of the cutting ability of exchangeable cutting inserts and the calculations for the comparison of the cutting abilities and recording the tool wear using a microscope. Article [7] describes the problems of cutting process monitoring in real time and focuses on the tool wear by means of impedance layers applied on ceramic cutting inserts.

Wireless sensor networks provide new possibilities to calculate tool wear through vibration monitoring of the work piece and/or spindle, which was not possible using traditional wired sensors, for example multi-sensor data fusion technique. Wireless sensing can also be applied to voltage, current and AE signals [8], as well as to facilitate a hybrid network of remote wireless machine condition monitoring sensors and radio frequency identification tags so that a technician can safely work using a personal computer [9]. Paper [10] adopts a more general perspective on the possibilities of using wireless sensor networking and nodes in manufacturing environments. Thus, the analysis therein demonstrates that condition-based monitoring and predictive maintenance of factory machinery in particular “open-architecture machining systems”, could greatly benefit from wireless sensor networks and the individual wireless sensor platforms in terms of research. The tests of the case study show a linear relationship occurring among the tool wear, surface finish and machine tool vibrations. As in modern advanced manufacturing, a smart cutting tool, essential to the high-precision machining, using two surface acoustic wave strain sensors mounted onto the top and side surface of the tool shank, respectively, is described in [11]. This surface acoustic wave-based, smart cutting tool is capable of measuring the cutting force and the feed force in a real machining environment. Article [12] presents a novel smart turning tool using the embedded piezoelectric sensors for real-time measurement of cutting forces in precision turning operations.

The authors of [13] predict the chatter in a ball-end milling operation using an accelerometer and dynamometer. They use optical method such as laser displacement sensors for vibration detection in the milling process. The authors of [14] propose the measurement technique suitable for monitoring vibration, chatter and tool wear in a rotating spindle [15].

For AE, the piezoelectric ceramics due to their high sensitivity and response is most effective. The transducer can detect stress-wave motions, which affect the material, cause its

dynamic displacement and transform the displacement into an electrical signal. The AE transducer has a frequency varying in the range of 20 kHz and 1 MHz, while the meaningful information of the AE signals in the machining are mostly above 100 kHz [16].

The application of AE to milling is not very straightforward, because it is an interrupted cutting operation with the rotating cutting tool causing shock pulses [17]. However, AE signals have high frequency and low amplitude, resulting in some studies focusing on the AE signal transmission system. However, to estimate the tool wear and breakage in the milling operation, some researchers use AE transducers directly mounted on the machine vice [18], on the machine table [19], on the work piece [20] and even on the main machine spindle or the cutting tool holder [21]. Paper [22] describes the application of sound signals for the monitoring of tool wear in the milling process. A sound signal has also been used by [23] in the turning process and by [24] in monitoring the milling process. The authors of [25] also use signals to evaluate cutting process stability. Moreover, [26] describes the use of ultrasonics to monitor tool wear during the turning process, but there has been no report about such a use in milling. The AE signals with cutting force, current, vibration [27] and laser techniques [28] give valuable information about the cutting process.

This paper aims at developing a more explicit system for monitoring tool condition by applying a self-powered wireless signal transmission, indicating the tool wear level, and AE techniques for the identification of treated surface roughness.

2 Self-powered wireless device for the detection of cutting tool wear

To evaluate the possibility to harvest energy from the rotating tool [29], it was necessary to develop a receiver and a special device with an accelerometer and wireless transmission of signals alimeted from batteries. The angular vibrations of the milling tool holder measured directly on the rotating tool and pronounced periodicity were present in the acceleration measurements carried out for the end milling operation. Milling itself is described as an interrupted cutting process because during each revolution of the cutter, its teeth enter and exit the work piece and they subjected to an impact force cycle. During this impact, the vibrations of the tool as well as those of the machine tool are excited. The amplitudes of these vibrations are considerably lower between the interrupted cutting periods than during the impact with the work piece. These amplitudes are insufficient for energy generation, so the most favourable are vibro-impact accelerations whose sequence intervals depend on the cutting regimes.

2.1 Identifying the mechanical part of self-powered wireless device

Having in mind that tool rotation at 3200 rpm provokes approximately 100 g eccentric force, the mass of the self-powered wireless device could influence the disbalance of the rotating tool. To prevent excessive vibration due to unbalance, three measures were taken—a rotating milling tool was balanced by counterweight attached to the opposite side of wireless device, the mass of the wireless device was designed only of 13.8 g and the used end milling tool was quite stiff.

It was necessary to find an appropriate type of the actuator capable to harvest a sufficient amount of energy for the wireless device to operate. For this reason, in the piezoelectric transducer, the mass squeezes the piezoelectric material due to the force resulting from any changes in acceleration or motion and, in turn, generates an electrical charge. To conduct this research, the Noliac piezoelectric cantilever CMBP04 was chosen. It is a multi-layered, co-fired piezoelectric transducer that operates at a low voltage and can be used to transform a bending moment into an electrical output. The transducer is usually employed when a low force causes a large displacement [30]. The piezoelectric cantilever is attached to the milling tool so that its vibration amplitudes coincide with the cutting direction and at the same time are perpendicular to the excentric force vector of rotating milling tool. Thus, the excentric force is bending the piezo cantilever in the maximum stiffness direction perpendicular to its vibration plane.

Figure 1 demonstrates the full architecture of the wireless vibration energy generator.

2.2 Identification of the electrical part of the self-powered wireless device

Generating and storing electrical energy require the elements of energy generation, transformation, stabilization and energy storage together with the elements from excessive surge protection (Fig. 2). Power converter or energy-generating element 1 is an energy converter which transforms mechanical energy into electrical. All power converters are most efficient at resonant regime, where the amount of generated energy increases from 2 to 100 times. The generated electric power by the power converter 1 is an AC current; therefore, it requires a diode bridge 2, which changes the power from AC to DC. For the diode bridge, Schottky diodes were used because of several reasons: they are faster and fall on the lower voltage (approximately 0.3 V) and perform better at high frequencies compared to conventional diodes. Element 3 is a Zener diode which protects against impermissible high voltage. Element 4 is a chip which increases voltage with a voltage stabilizer depending on the required stabilized DC voltage which is used to power the electronics and voltage amplitude generated by

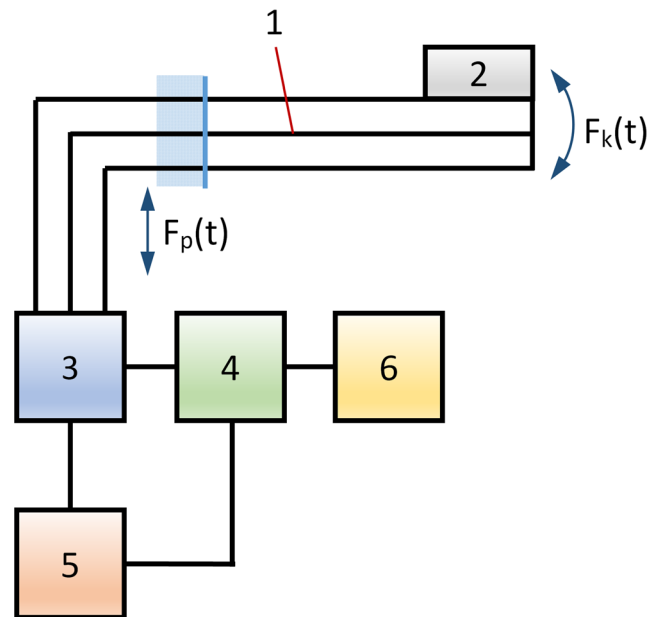

Fig. 1 Full architecture of wireless vibration energy generator: 1 cantilever; Noliac CMBP piezoelectric transducer; 2 concentrated inertial mass for the tuning of resonant frequency; 3 connection unit; 4 controller; 5 electrical energy accumulator; 6 wireless transmitter; $F_k(t)$ dynamic force, generated by the piezotransducer function; $F_p(t)$ dynamic force, generated by the cutting tool function

the inverter. Element 5 is an energy storage capacitor, while element 6 functions as a microcontroller.

To convert electrical energy generated by the energy transducer to the microcontroller voltage level, a subsystem of electrical energy conversion was developed. The primary transducer, piezo generator, converts the energy of mechanical vibrations into electrical energy, which is variable and must be of sufficiently large amplitude. The created subsystem functions as a secondary transducer that converts variable voltage into direct constant voltage, which can be modified. This transducer was designed using a Linear Technology LTC3588-1 microchip into which a diode bridge, Zener diode and AC/DC voltage decreasing converters were integrated.

2.3 Power conversion input and output

Power conversion subsystem performance is shown with removed signals, charging 100 μ F capacitor (Fig. 3). When output voltage reaches the target voltage of 2.5 V, the output induces that stabilized voltage does not go out of the constrained boundaries. This signal is fed to the measuring electronics.

As it is seen from the Fig. 3, the output voltage reaches 6 V without load and 2.5 V with load. Experimental results have showed instability of high-amplitude tool vibrations. In order to increase the efficiency of energy collection from piezo transducer, the system was improved and Schottky diode bridge was replaced with an input voltage quadrupler.

Fig. 2 Components of the energy recovery and storage device: 1 power inverter; 2 diode bridge; 3 guard element; 4 voltage conversion and stabilization electronics; 5 energy storage element; 6 powered electronics

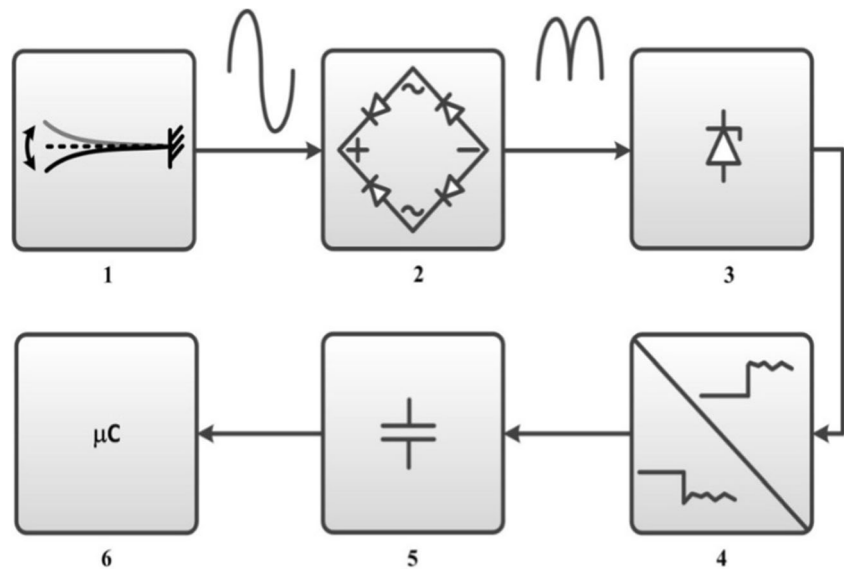

Cutting is often performed under aggressive conditions aiming at high rates of material removal, which causes chatter with excessive cutting force and intensive vibrations at the cutting place of the tool. Figure 4a shows the architecture of the wireless sensor node (WSN) embedded into a cutting tool.

During WSN operation, processing and power management are carried out by using the industrial, scientific and medical (ISM) radio bands reserved internationally for the use of radio frequency (RF) energy for industrial, scientific and medical

purposes other than telecommunications and ultra-low-power (ULP) microcontroller units (MCU) since the power has to be strictly controlled. The Texas instruments MCU-MSP430, was ideal for energy harvesting for its characteristics: it has a standby current of less than 1 μA and an active current of 160 A/MHz, a quick wakeup time of less than 1 μs , and a temperature sensor inside; besides, it operates at the range of 1.8–3.6 V common MCU. After the experimental tests, the developed sensor has showed that at the beginning of the charging process of the sensor subsystem (energy converter or processor and radio transmitter), it goes to an uncertain state—power consumption strongly exceeds the current generated by the piezo transducer. This stops the charging process and the sensor is not able to switch to the measuring mode. Advanced sensor architecture with separate ULP charge detection with reduced energy consumption during MCU startup process was elaborated (Fig. 4b). The system only uses the energy for input voltage until the capacitor is fully charged. This prototype fully satisfied energy needs for sensor supply and is capable to transmit information at the distance of 20 m.

Figure 5 shows the general view of the developed wireless energy harvester prototype.

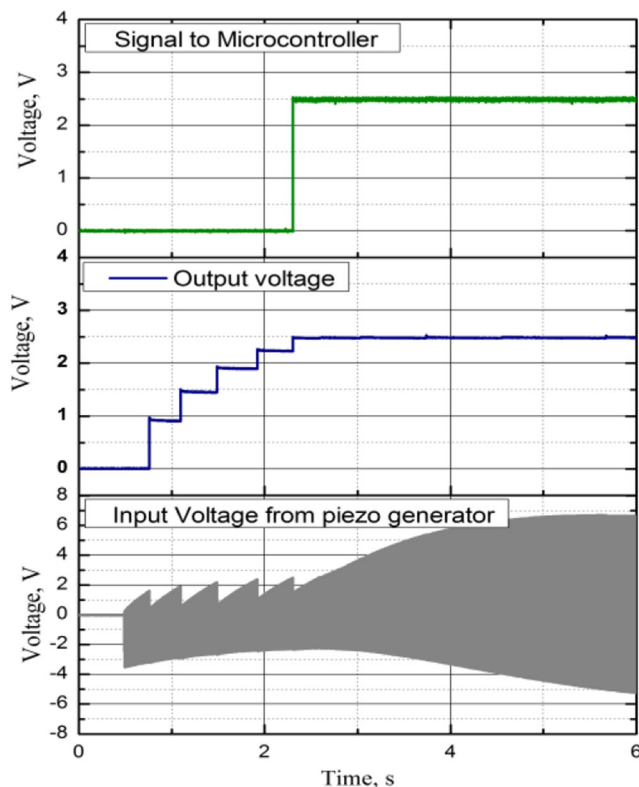

Fig. 3 Power transducer subsystem signals charging 100 μF capacitor

3 Experimental tests

The experiment was done on a steel work piece with face mill working regimes: 4—tooth mill feed—0.1 mm/rev, speed—3200 rpm; depth of the cut—1 mm. Two kinds of mills were chosen: one was a new mill and the other was worn. These two mills were expected to show different results: predictably, the worn mill would have higher resonance frequency amplitudes due to higher vibrations. A simple 1-mm depth, 5-mm milling edge of the tool on the work piece, with the feed rate of 600 mm/min and 3200 rpm, was chosen, and a “zigzag” milling principle was applied.

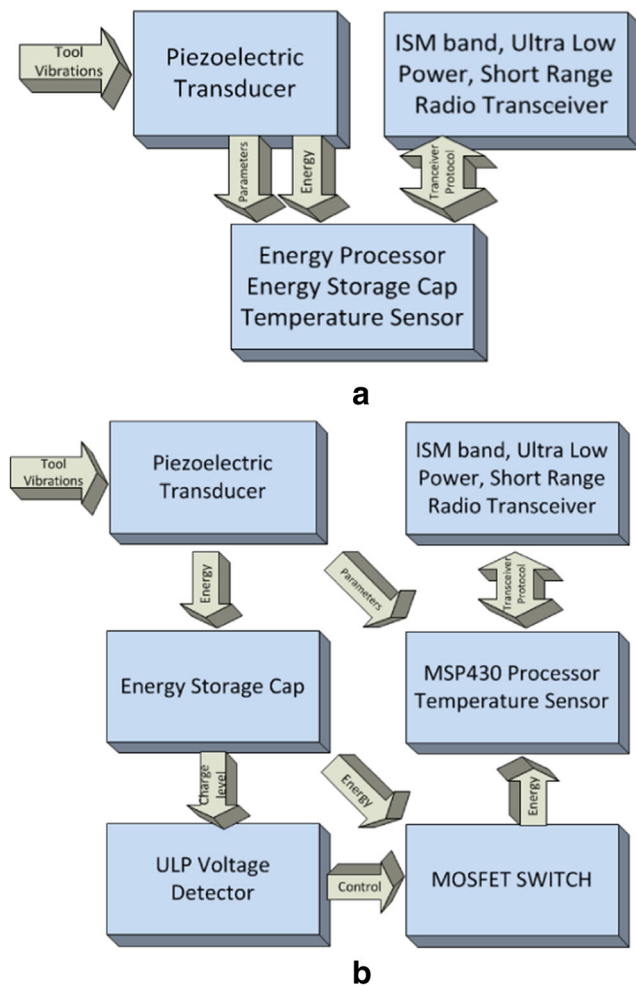

Fig. 4 Wireless sensor node design of a smart tool: architecture of the wireless sensor node (a) and advanced sensor architecture with separate ULP charge detection (b)

The further experiment was organized to show the influence of the tool wear on the frequency of wireless

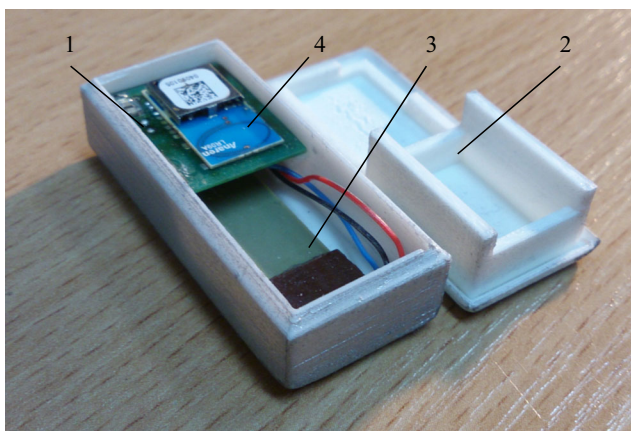

Fig. 5 General view of the electrical energy harvester (length × width × depth = 44 × 20 × 18 mm, mass 13.8 g): 1 case; 2 cover; 3 piezoelectric cantilever of type CMBP05 (Noliac A/S, Denmark), 4 controller with wireless transmitter

information transmission to the receiver (Fig. 6). During milling operation, piezoelectric harvester was excited by the mill vibrations and the harvested energy was accumulated by a 100-μF capacitor.

Figure 6a suggests that the maximum output voltage of the vibration harvester when cutting the new tool is 2 V. The generated voltage of the harvester was exponentially rising until the capacitor was fully charged and a wireless signal sent to the receiver. The time intervals of sending the signal amounted to ~28 s (the signal is marked in red).

When the tool life comes to an end and its cutting edge becomes worn out, the signal amplitude of the accelerometers (Fig. 6b) as well as the frequency of wireless transmission of the measured results increases while the time interval decreases by approximately 2–3 times down to ~10 s.

For the identification of the wear level of the milling tool, the industrial wear measuring device Zoller Smile V300 was used (Fig. 7).

4 Application of wireless sensor for the detection of milling tool wear in industrial environment

CNC milling machine tool Optimum Optimill F150 (Fig. 8) was used for machining three types of the most popular industrial materials: stainless steel 1.0037-St37-2/S235JR, steel 1.4057 and aluminium alloy. A few cutting speeds *n* and feeds *f* were chosen for the experiments, and surface roughness was measured three times; hence, Fig. 9 provides the average results.

Parameters for milling surface with new and worn-out tools are presented in Table 1.

Figure 9 presents the dependence of work piece roughness on the duration of the harvested energy accumulation process under different cutting regimes for (a) steel, (b) stainless steel and (c) aluminium alloy milling.

The experimental results show that the accumulation process of the vibration energy harvested by the worn mill is 2–3 times faster compared to the accumulation process from the new mill independently from the material of the work piece. In contrast, after treatment with the worn mill, the roughness of the work piece surface exceeds the roughness obtained with the new mill by 2–3 times.

5 Acoustic emission measurement results and discussion

Acoustic emission (AE) can be defined as transient elastic waves developed by rapidly releasing energy from stable source(s) in a material, or the phenomenon generating such

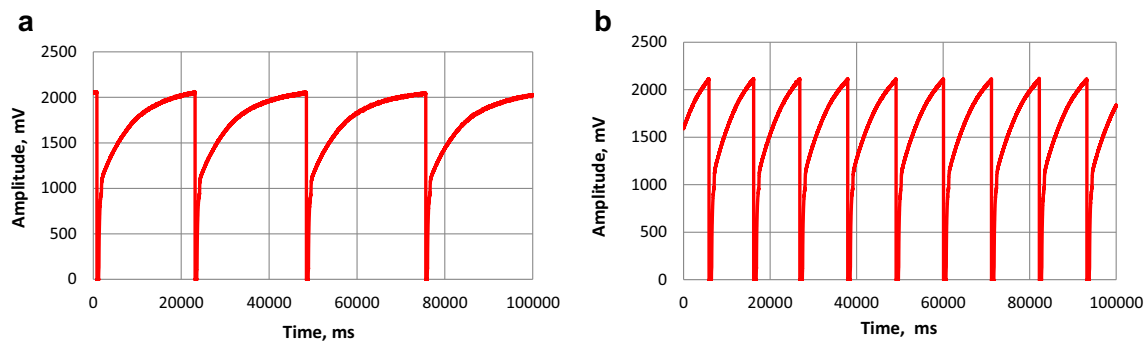
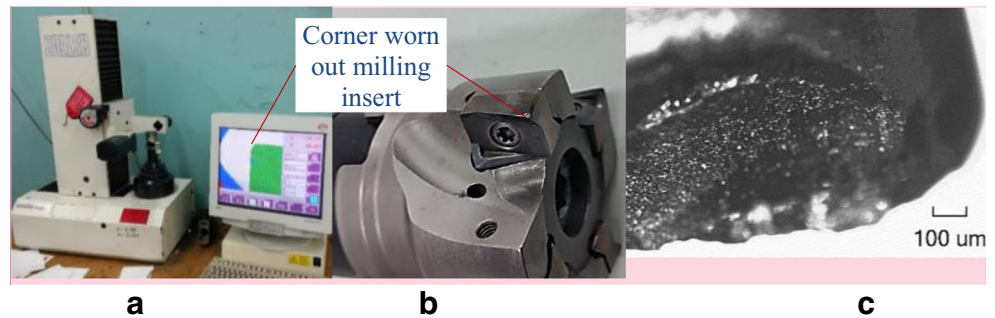

Fig. 6 Exponentially rising voltage generated by the harvester when milling a steel work piece with the new (a) and worn (b) tools; the time of the capacitor charge up to 2 V is ~ 28 s for the new and ~ 10 s for the worn tool

Fig. 7 Zoller Smile v300 tool wear measuring device (a), corner worn-out end milling insert (b) and its Nikon ECLIPSE LV150 microscope digital picture ($\times 5$) (c)



waves. The best reason of using AE for controlling the condition of the tool is that the frequency range of an AE signal does not interrupt cutting, because it is considerably bigger than the range of the environmental noises and machine vibrations. According to the results of the research, AE of the stress waves, derived by abruptly releasing energy from deforming materials, was effectively applied to determine tool wear during the milling operations in laboratory tests.

5.1 Measurement of AE signals

The device for measuring AE was elaborated for evaluating the reliability of vibrational analysis. AE can be described as non-fixed signals that very often consist of overlapping transients with unknown waveforms as well as the arrival time. The biggest problem of processing an AE signal is obtaining proper physical characteristics, such as tool wear, when they include variations of frequency and time.

Fig. 8 Industrial setup for the experiment: 1 CNC milling machine tool Optimum Optimill F150; 2–4 tooth mill $D = \varnothing 50$; 3 electrical energy harvester with the energy accumulation and wireless transmitter; 4 work piece; 5 PC; 6 diagnostic signal (Wi-Fi) receiver; 7 roughness measurement device

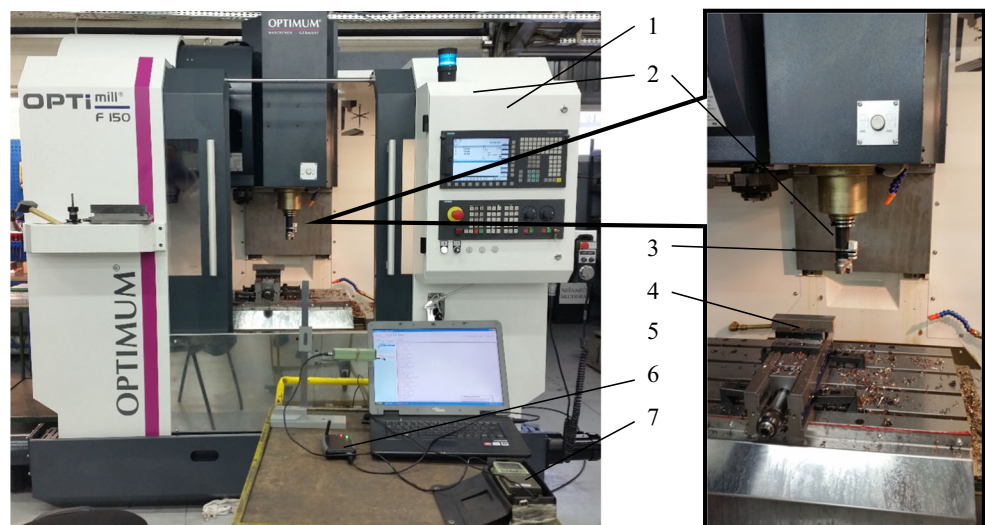
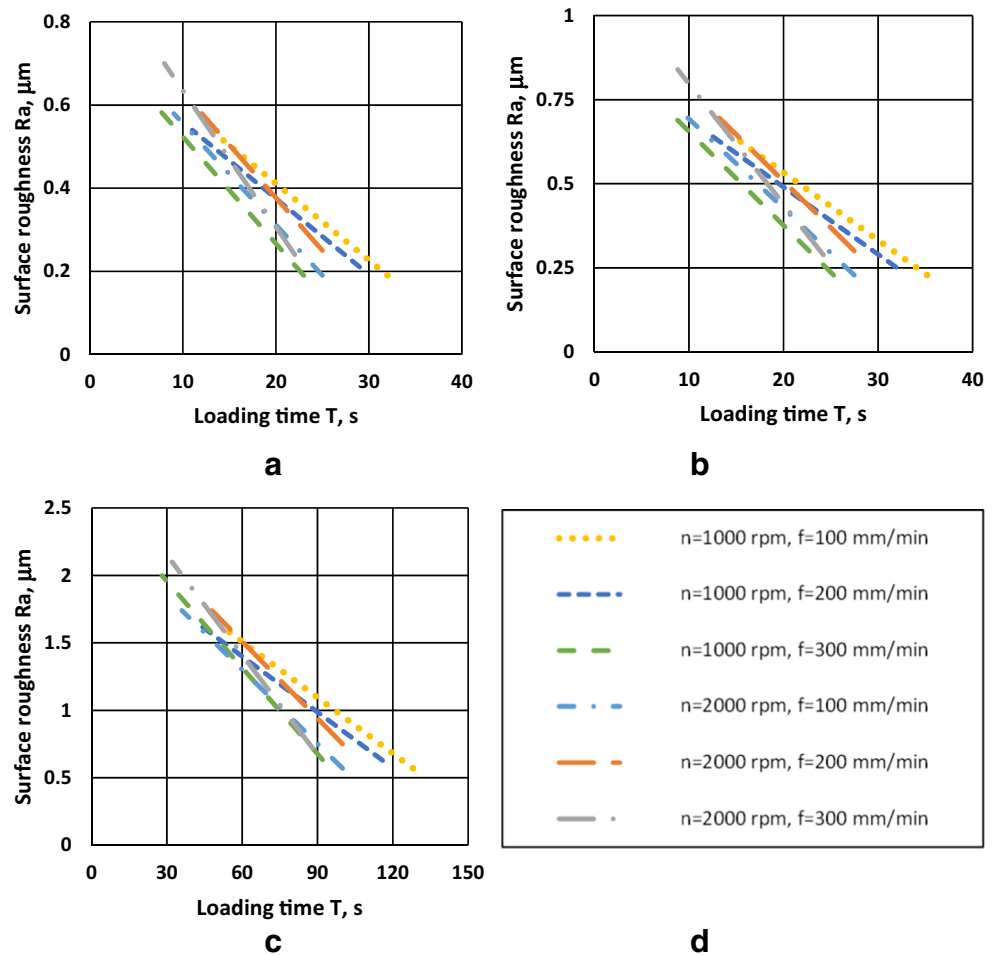

Fig. 9 Dependence of work piece roughness on the duration of the harvested energy accumulation process under different cutting regimes for (a) steel, (b) stainless steel and (c) aluminium alloy milling, (d) marking of cutting regimes



Fast Fourier transform (FFT) was used to analyse AE signals and identify frequency diapasons (Fig. 10).

As milling can be described as an interrupted cutting process because during each revolution of the cutter, its teeth enter and exit the work piece, and in this way, they are subjected to an impact force cycle. It can be seen from Fig. 10a that the 120-Hz frequency dominates as a result of mill tooth and work piece material collision. During this impact, the vibrations of the cutting tool are excited. When the milling tool is worn out, this signal is blanketed by the increased noise level (Fig. 10b). Comparing the noise spectrums of the new and worn mills (Fig. 9), registered by the microphone placed near the cutting zone, a 10-dB level difference is evident, which coincides with the 3 times difference in the amplitudes.

As a result, the dynamic interaction between the work piece and the cutting tool, self-excited vibrations distort the quality of the surface and deteriorate the lifetime of the tool. Moreover, machining process may become less effective due to the occurring vibrations and may reduce the capacity of chip removal of the tool. A typical type of vibrations occurring in the process is regenerative chatter

where varied thickness of the chip causes excitation in the machine-tool-work piece system. Figure 11 illustrates the vibrations of the work piece measured by an accelerometer attached to it. Given scans of the vibration, signals were measured in the radial direction of the milling tool at 2000 rpm.

Figure 11 clearly demonstrates the increase of work piece excitation level under the worn mill cutting.

5.2 Ultrasound measurements of the impact of the relative location of the tool and work piece on the identification of surface finishing and tool wear

The results of ultrasound measurements were registered by a crafted sensor of AE, whose general view and structure are presented in Fig. 12. The sensor of AE (Fig. 12a) is composed of the housing 1, which has a disc-shaped piezoelectric actuator 3, electrodes 5, 6, and wires 7, 8 by which the measured AE signal is transmitted to the measuring device. From the direction of the acoustic signal, the piezoelectric actuator is armoured by a ceramic disc 2 and a diaphragm-screen

Table 1 Parameters for milling surface with new and worn-out tools

No.	Tool condition	Cutting data			Surface roughness				Loading time T , s
		Spindle speed n , rpm	Feedrate f , mm/min	Cutting deep a_p , mm	1Ra, mm	2Ra, mm	3Ra, mm	\hat{a} Ra, mm	
Steel 1.0037									
1	New	1000	100	1	0.20	0.16	0.21	0.19	32
2	Worn	1000	100	1	0.58	0.45	0.60	0.54	13
3	New	1000	200	1	0.22	0.18	0.23	0.21	29
4	Worn	1000	200	1	0.58	0.45	0.60	0.54	11
5	New	1000	300	1	0.20	0.16	0.21	0.19	23
6	Worn	1000	300	1	0.64	0.50	0.67	0.60	7
7	New	2000	100	1	0.20	0.16	0.21	0.19	25
8	Worn	2000	100	1	0.62	0.49	0.64	0.58	9
9	New	2000	200	1	0.27	0.21	0.28	0.25	25
10	Worn	2000	200	1	0.62	0.49	0.64	0.58	12
11	New	2000	300	1	0.26	0.20	0.27	0.24	22
12	Worn	2000	300	1	0.75	0.59	0.78	0.70	8
Stainless steel 1.4057									
1	New	1000	100	1	0.24	0.19	0.25	0.23	35.2
2	Worn	1000	100	1	0.69	0.54	0.72	0.65	14.3
3	New	1000	200	1	0.27	0.21	0.28	0.25	31.9
4	Worn	1000	200	1	0.69	0.54	0.72	0.65	12.1
5	New	1000	300	1	0.24	0.19	0.25	0.23	25.3
6	Worn	1000	300	1	0.77	0.60	0.80	0.72	7.7
7	New	2000	100	1	0.24	0.19	0.25	0.23	27.5
8	Worn	2000	100	1	0.74	0.58	0.77	0.70	9.9
9	New	2000	200	1	0.32	0.25	0.33	0.30	27.5
10	Worn	2000	200	1	0.74	0.58	0.77	0.70	13.2
11	New	2000	300	1	0.31	0.24	0.32	0.29	24.2
12	Worn	2000	300	1	0.90	0.71	0.93	0.84	8.8
Aluminium alloy									
1	New	1000	100	1	0.61	0.48	0.63	0.57	128.0
2	Worn	1000	100	1	1.73	1.36	1.80	1.62	52.0
3	New	1000	200	1	0.67	0.53	0.70	0.63	116.0
4	Worn	1000	200	1	1.73	1.36	1.80	1.62	44.0
5	New	1000	300	1	0.61	0.48	0.63	0.57	92.0
6	Worn	1000	300	1	1.93	1.51	2.00	1.80	28.0
7	New	2000	100	1	0.61	0.48	0.63	0.57	100.0
8	Worn	2000	100	1	1.86	1.46	1.93	1.74	36.0
9	New	2000	200	1	0.80	0.63	0.83	0.75	100.0
10	Worn	2000	200	1	1.86	1.46	1.93	1.74	48.0
11	New	2000	300	1	0.77	0.60	0.80	0.72	88.0
12	Worn	2000	300	1	2.25	1.76	2.33	2.10	32.0

4, characterised by low damping. From the backside, the acoustic signal-damping compound 9 is placed ensuring the sensing direction. The frequency diapason of the acoustic sensor is from 10 Hz to 2 MHz and its overall dimensions equal to $\varnothing 16 \times 22$ mm.

Surface roughness has a significant influence on how the completed components perform. In milling, the surface quality itself is affected by different technological specifications, for example the properties of the work piece and the cutting tool, or the conditions of cutting.

Fig. 10 In case of the new mill (a), the average noise level is -65 dB, the frequency of the mill tooth and work piece material collision is 120 Hz; in case of the worn mill (b), the average noise level is -55 dB, the frequency of the mill tooth and work piece material collision is inhibited by the noise of higher frequencies

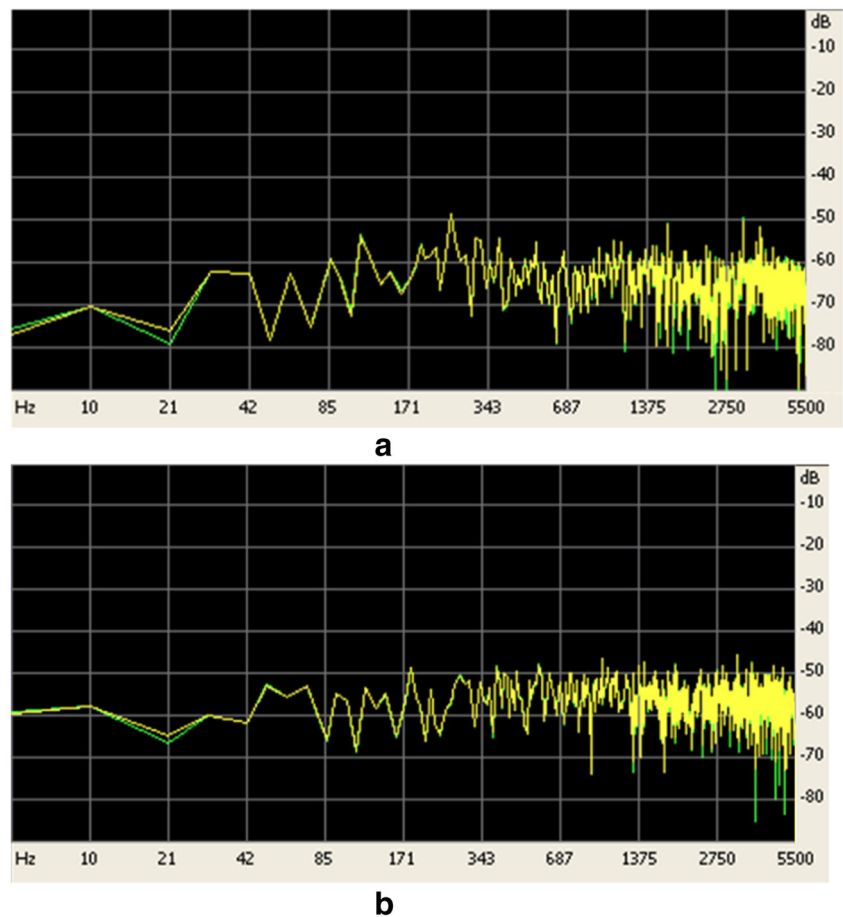

However, literary sources do not cover the impact of the relative location of the work piece and tool on the surface roughness of the former or the lifetime of the latter. That is why the results of the dependence of the surface roughness on the milling tool position could be interesting. During face milling, the measurements of roughness were realized in 1, 2, and 3 positions according to the scheme in Fig. 13 and compared to the acoustic emission measured for the relative mill and work piece behaviour in the indicated positions (Fig. 14).

The analysis of AE signals excited by the new (Fig. 14) and the worn (Fig. 15) milling tools clearly shows that the most favourable position from the point of view of possible chatter excitation is related to the relative tool-work piece location 2, which assures a higher work piece stiffness under the action of the milling forces. The test results suggest that the amplitude of the acoustic signal generated in the work piece material is more than twice lower for the new mill than for the worn one. However, the character of the acoustic signal in the diapason from 20 to 100 kHz is similar for the

new (Fig. 14a) and for the worn tool (Fig. 15a). It is evident that the cutting forces of the worn tool excite more intensive vibrations of the work piece, which have a resonance frequency equal to 10 kHz (Fig. 15a). According to the fixing scheme of the work piece in Fig. 13, when the cutting starts (1 position) or ends (3 position), these parts of the work piece could be considered as cantilever beams, the stiffness of which is lower than in the case of the 2 position.

This statement was confirmed by measuring the surface roughness in the indicated points (Fig. 16).

5.3 Identification of the cutting tool precision by acoustic emission measurement

Acoustic emission measurement could be useful for the identification of the new tool precision by narrow band envelope analysis of the raw time waveform from the AE sensor. The magnitude modulation of the envelope signal can be used as the fault development indicator. Figure 17 shows the envelope signal of the tool.

Fig. 11 Vibration signal of the work piece measured by an accelerometer KD 91 when milling with a new (a) and worn (b) cutting tool

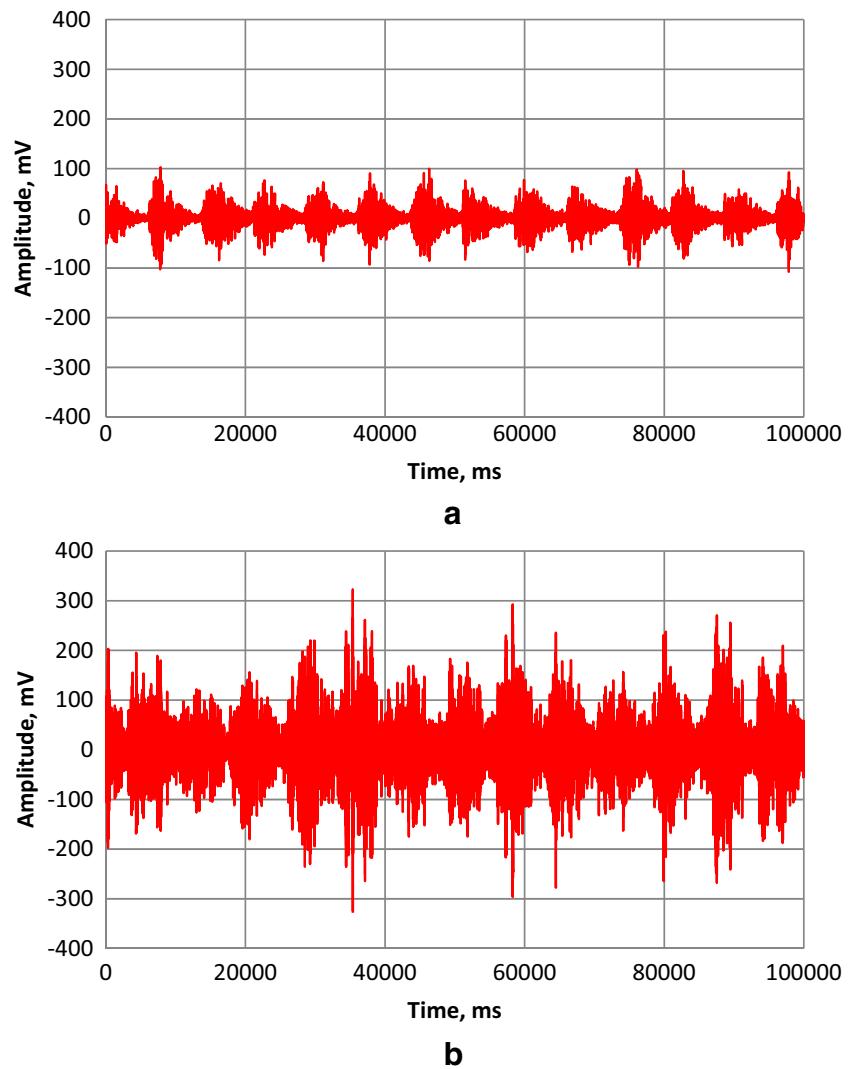

Figure 17 demonstrates that the end mill tooth No. 1 generates by 50 % more intensive signals compared to the tooth in opposite side of the mill. The reason of this phenomenon is that the tooth No. 1 is different from the other tooth. From the

given vibrogram, it is possible to judge about the quality of the new milling tool and to improve it before use. For such an evaluation, it is necessary to accomplish vibrodiagnostic investigation on the stand presented in Fig. 18. This stand

Fig. 12 Structure (a) and general view (b) of AE sensor: 1 housing; 2 element of acoustic contact; 3 piezoelectric element; 4 diaphragm-screen; 5, 6 the electrodes of piezo element; 7, 8 cables; 9 compound for the acoustic signal suppression

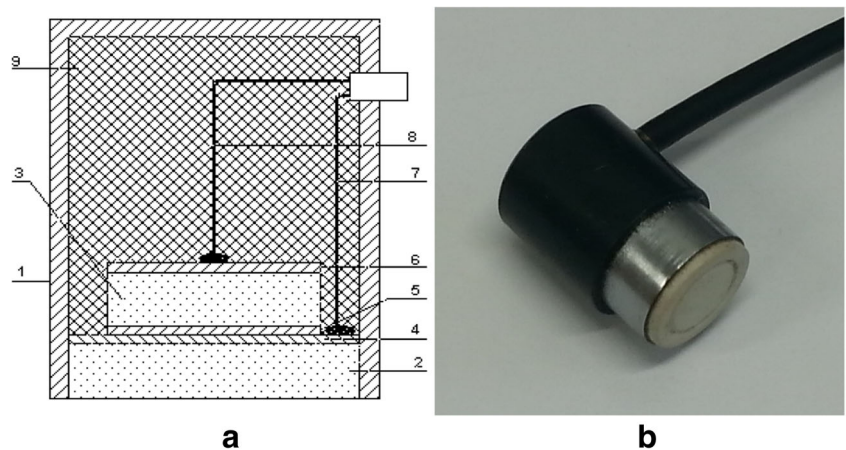

Fig. 13 Relative positions of the end mill and work piece during the measurements

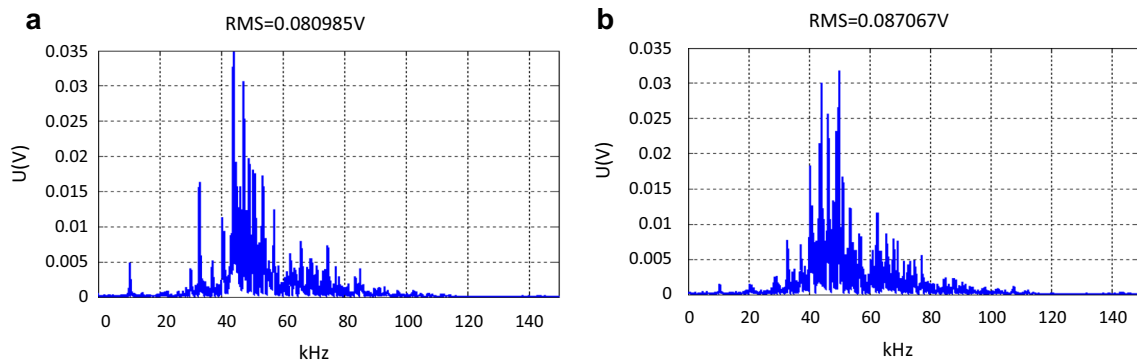
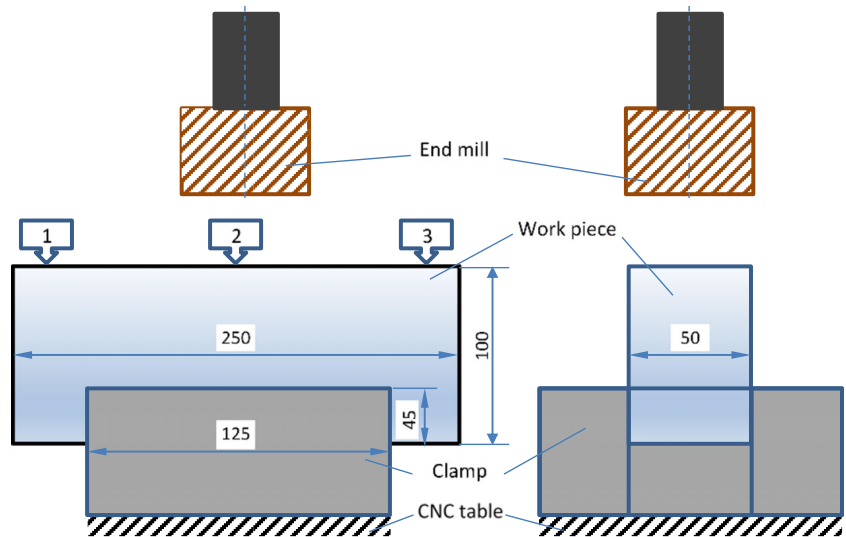

Fig. 14 Acoustic emission signal in the work piece for the new mill in 1 and 3 (a), 2 (b) positions

contains not only the sensor of the vibrational level but also an additional sensor of the mill tachometer signal generator. This stand enables to identify which tooth generates the higher-level vibrations.

Figure 19 provides the general view of the setup of the technical state evaluation sensors of the mill.

5.4 Statistical evaluation of a wirelessly unregistered tool condition on the quality of milling

The cutting conditions in milling directly influence the production, which concerns not just time but also quality. Therefore, finding a suitable compromise among the surface

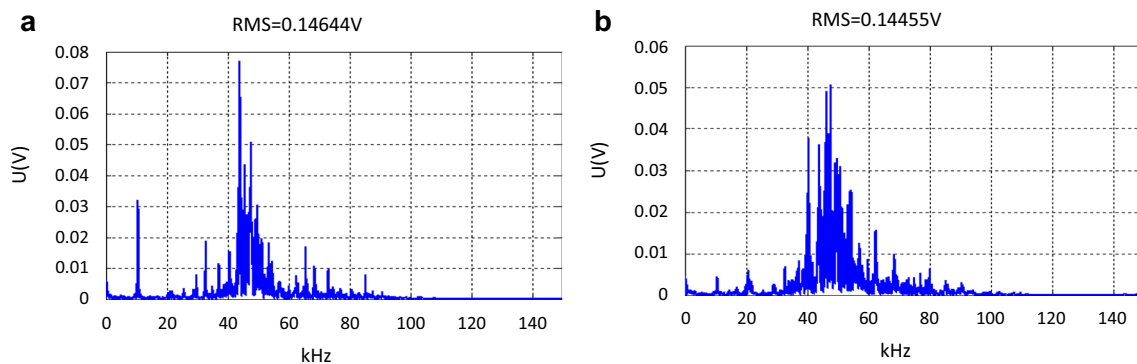

Fig. 15 Acoustic emission signal in the work piece for the worn mill in 1 and 3 (a), 2 (b) positions

Fig. 16 Dependence of the surface roughness measured at different relative positions of the cutting tool-work piece

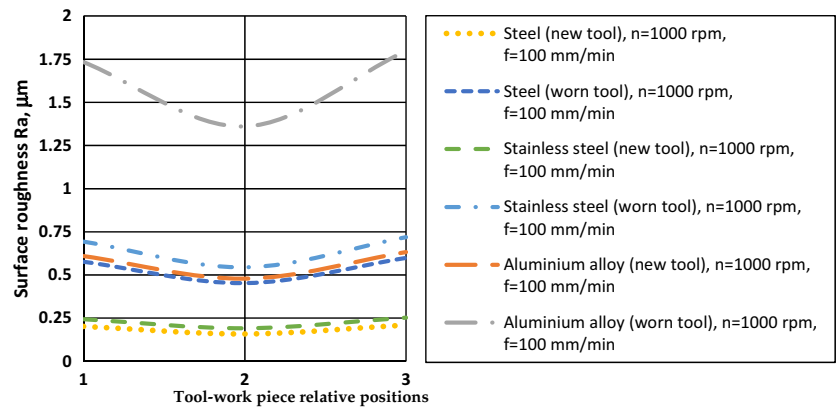
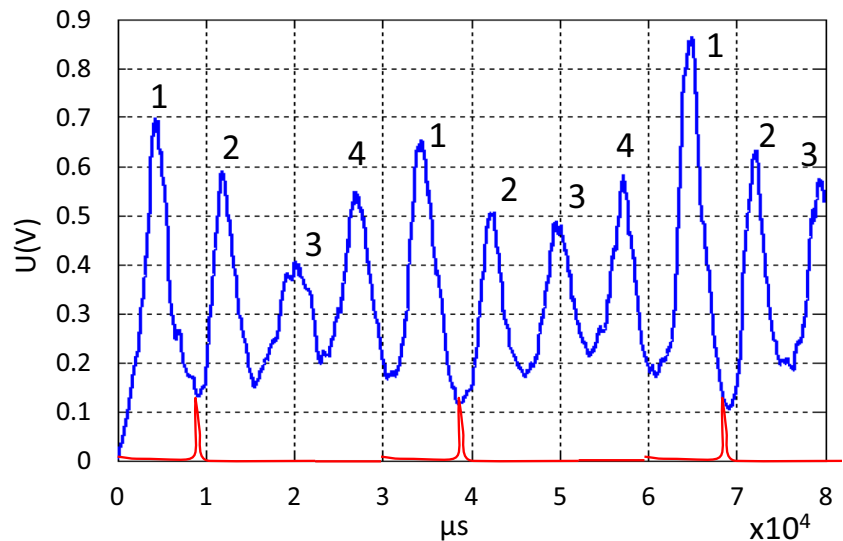

Fig. 17 Envelope signal of the waveform generated by the 4-tooth face mill (blue curve) and tachometer signal of the rotating mill (red curve); 1, 2, 3 and 4 signify the tooth number, which generates vibrational impulse when striking the work piece



quality, condition and productivity of the cutting tool is one of the main objectives of the CNC machining centre. The proposed new method for the identification of milling tool condition is based on the excited mechanical vibration energy transformation to an electrical signal. According to this method, the accumulation time of harvested energy, which correlates with the cutting tool wear level, depends on such

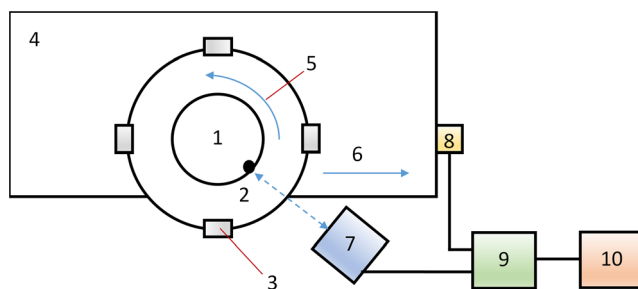

Fig. 18 Structural scheme of the vibrodiagnostic stand for mill technical state evaluation: 1 mill axis; 2 mark of tachometer signal; 3 mill teeth; 4 work piece; 5 direction of mill rotation; 6 feed direction of the work piece; 7 shaper of tachometer signal; 8 accelerometer; 9 oscilloscope; 10 PC with vibrodiagnostic analysis software

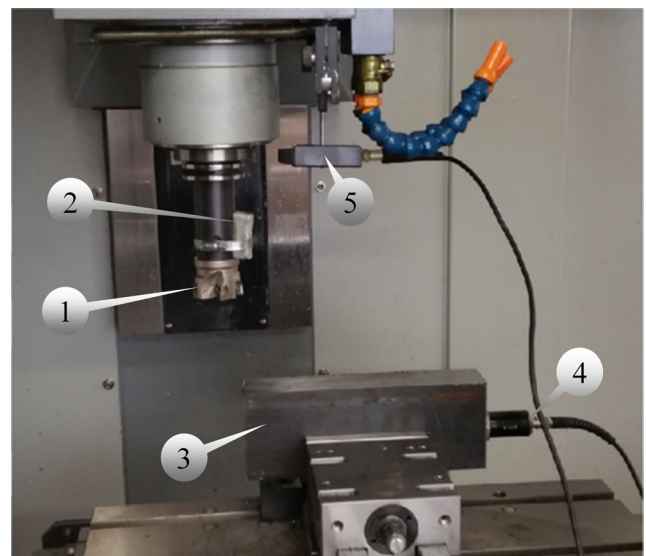

Fig. 19 General view of the set-up of the technical state evaluation sensors of the mill: 1 mill; 2 Wi-Fi vibrational level sensor; 3 work piece; 4 accelerometer BK-310A; 5 transmitter of tachometer signal

Table 2 Results of variance analysis of the milling process

Analysis of variance					
Source	Sum sq.	d. f.	Mean sq.	<i>F</i>	Prob > <i>F</i>
Material	5299.55	2	2649.78	18.82	0.0092
Cutting speed	297.68	1	297.68	2.11	0.2196
Cutting feed	177.78	2	88.89	0.63	0.5777
Material*speed*	139.36	2	69.68	0.49	0.6426
Material*feed	83.23	4	20.81	0.15	0.9545
Speed*feed	1203.25	2	601.56	4.27	0.1017
Error	563.97	4	140.81		
Total	7763.97	17			

* used to mark means reciprocity

parameters as the type of work piece material, speed (rev/min) and feed (mm/min) of the tool cutting. The proposed experiment of three-factorial influence estimation was carried out to determine the relative value of the time when the identification signal, informing about tool condition, is formed and the evaluation of the interaction of the parameters. For a statistical experiment, the results of the three types of work piece materials (stainless steel 1.0037-St37-2/S235JR, steel 1.4057 and aluminium alloy), the two levels of cutting speeds (low level 1000 rpm and high level 2000 rpm) and the three levels of the feed values (low level 100 mm/min, medium level 200 mm/min and high level 300 mm/min) were used. The interval of the identification signal, informing about the tool state and the formation time, is appreciated in seconds. For the statistical

experiment, three-factor two-level analysis of variance (ANOVA) statistical method was chosen to determine the experimental results of the dispersion analysis, meaning that in every population the considered properties are normally distributed and have the same dispersion. After the dispersion analysis, the following results were submitted: the sum of squares (Sum sq.), their degrees of freedom (d. f.), mean squares (Mean sq.), *F* criterion and its *p* value. If *p* exceeds the chosen importance level α , then the null hypothesis is unquestioned. In other words, the experimental results provide no basis for claiming that the factor has a reliable impact on the measured variable. However, if $p \leq \alpha$, then the null hypothesis is rejected, i.e. the factor has a reliable impact on the measured variable. The purpose of the statistical experiment is to evaluate if the work piece material, cutting speed, feed rate and their interplay have influenced a change in the time interval of the formation of the wirelessly transmitted identification signal, updating the tool condition, or if the average differences in the time interval of identification signal formation are statistically important. Table 2 gives the results of the analysis of milling.

Table 2 provides the sum squares, their degrees of freedom, mean squares, *F* criterion and its *p* value. It is evident that under the influence of one factor, i.e. work piece material, *p* value of *F* criterion is less than 0.05, that is why the conclusion that different work piece materials have influenced the time of identification signal formation is statistically significant. Other factors and their interactions did not statistically influence the formation time of the identification signal. It is relevant to have the

Fig. 20 Comparison of the marginal mean of the materials for the milling operation

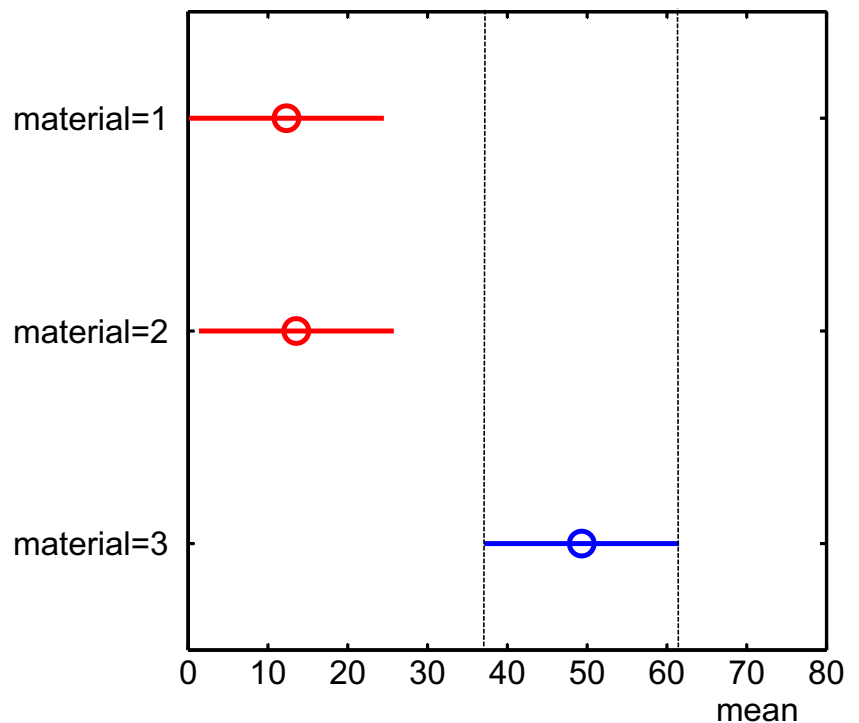

information about both the pairs of means that are considerably distinct and those that are not, so a multiple comparison method was applied as a test that provides such information. Figure 20 presents a multiple comparison of marginal means of the population and suggests that the marginal mean of material 3 is significantly different from those of material 1 and material 2.

In this case, material 1 and material 2 are stainless steel and steel, the physical and mechanical properties of which are approximate similarly as the marginal mean of the identification signal formation time, while material 3, aluminium alloy, that has different properties of marginal mean. While marginal mean of the materials are considerably different, from the analysis, it is evident that the influence of different work piece materials on the identification signal time interval is statistically significant. Therefore, it is essential to compose the dependence of identification signal formation time interval on the physical properties of the material and their machinability parameters. Thus, the operator will be obliged to indicate only the code of work piece material as the distinguishing feature.

6 Summary and conclusions

The use of sensors in machining provides significant information about tool conditions, including tool wear, breakage and chatter, which influence the quality of the machined surface and production time. In order to apply in industry, a low-cost, small in size, robust, non-invasive and interfering technique with the working space is proposed. The value of this technology can be realized when reliable sensors are deployed in milling operations with rotating tools using wireless data transmission systems. The implementation of innovative sensors and their integration into technical condition monitoring systems considered as a research challenge in the future to enhance machining systems and their operations.

Acknowledgments This work has been supported through EC funding for the FP7 project M-Future 2013 (319179) and was funded by the EU Structural Funds project “In-Smart” (No. VP1-3.1-ŠMM-10-V-02-012), the Ministry of Education and Science, Lithuania.

Open Access This article is distributed under the terms of the Creative Commons Attribution 4.0 International License (<http://creativecommons.org/licenses/by/4.0/>), which permits unrestricted use, distribution, and reproduction in any medium, provided you give appropriate credit to the original author(s) and the source, provide a link to the Creative Commons license, and indicate if changes were made.

References

- Song DY, Otani N, Aoki T, Kamakoshi Y, Ohara Y, Tamaki H (2005) A new approach to cutting state monitoring in end-mill machining. *Int J Mach Tools and Manuf* 45(7-8):909–921
- Dimla DE (2000) Sensor signals for tool-wear monitoring in metal cutting operations—a review of methods. *Int J Mach Tools Manuf* 40(8):1073–1098
- Baccar D, Soffker D (2015) Wear detection by means of wavelet-based acoustic emission analysis. *Mech Syst Sygn Proc* 60–61: 198–207
- Bhuiyan MSH, Choudhury IA, Nukman Y (2012) Tool condition monitoring using acoustic emission and vibration signature in turning. *Proceedings of the World Congress on Engineering III WCE*
- Ghani JA, Rizal M, Nuawi MZ, Ghazali MJ, Haron CHC (2011) Monitoring online cutting tool wear using low-cost technique and user-friendly GUI. *Wear* 271:2619–2624
- Čep R, Janásek A, Čepová L, Petru J, Hlavatý I, Car Z, Hatala M (2013) Experimental testing of cutting inserts cutting ability. *Tehn Vjesn/TechnTehn Vjesn/Techn Gaz* 20(1):21–26
- Sadilek M, Kratochvíl J, Petru J, Čep R, Zlámál T, Stančeková D (2014) Cutting tool wear monitoring with the use of impedance layers. *Tehn Vjesn* 21(3):639–644
- Ghosh N, Ravi YB, Patra A, Mukhopadhyay S, Paul S, Mohanty AR, Chattopadhyay AB (2007) Estimation of tool wear during CNC milling using neural network-based sensor fusion. *Mech Syst Signal Process* 21(1):466–479
- Ramamurthy H, Prabhu BS, Gadh R, Madni AM (2007) Wireless industrial monitoring and control using a smart sensor platform. *IEEE Sensors J* 7(5-6):611–618
- Wright P, Dornfeld D, Ota N (2008) Condition monitoring in end-milling using wireless sensor networks (WSNs). *Trans NAMRI/SME* 36:177–183
- Wang C, Cheng K, Chen X, Minton T, Rakowski R (2014) Design of an instrumented smart cutting tool and its implementation and application perspectives. *Smart Mater Struct* 23(3):350–362
- Xiao CW, Ding H, Cheng K (2015) Design of an innovative smart turning tool with application to real-time cutting forces measurement. *Proc I Mech Eng B: J Eng Manuf* 229(3):563–568
- Kim SJ, Lee HU, Cho DW (2007) Prediction of chatter in NC machining based on a dynamic cutting force model for ball end milling. *Int J Mach Tool Manuf* 47:1827–1838
- Tatar K, Gren P (2008) Measurement of milling tool vibrations during cutting using laser vibrometry. *Int J Mach Tool Manuf* 48: 380–387
- Nakagawa H, Kurita Y, Ogawa K, Sugiyama Y, Hasegawa H (2008) Experimental analysis of chatter vibration in end-milling using laser Doppler vibrometers. *Int J Automat Technol* 2(6):431–438
- Li X (2002) A brief review: acoustic emission method for tool wear monitoring during turning. *Int J Mach Tool Manuf* 42:157–165
- Li X, Guan XP (2004) Time-frequency-analysis based minor cuttingedge fracture detection during end milling. *Mech Syst Signal Process* 18:1485–1496
- Mathew MT, Pai PS, Rocha LA (2008) An effective sensor for tool wear monitoring in face milling: acoustic emission. *Sadhana* 33(3): 227–233
- Jakobsen LA, Wilkinson P, Barton JS, Reuben RL, Harvey D, Jones JDC (2005) The effects of progressive wear on the frequency characteristic of acoustic emission acquired during face milling. *P I Mech Eng B-J Eng* 219:803–810
- Cao H, Chen X, Zi Y, Ding F, Chen H, Tan J, He Z (2008) End milling tool breakage detection using lifting scheme and Mahalanobis distance. *Int J Mach Tool Manuf* 48:141–151
- Xiqing M, Chuangwen X (2009) Tool wear monitoring of acoustic emission signals from milling processes. *Proceeding of the 1st International Workshop on Education Technology and Computer Science*
- Ai CS, Sun YJ, He GW, Ze XB, Li W, Mao K (2012) The milling tool wear monitoring using the acoustic spectrum. *Int J Adv Manuf Technol* 61(5-8):457–463

23. Nuawi MZ, Lamin F, Ismail AR, Abdullah S, Wahid Z (2009) A novel machining signal filtering technique: Z-notch filter word academic science. *Eng Technol* 54(54):24–29
24. Rubio EM, Teti R (2009) Cutting parameters analysis for the development of a milling process monitoring system based on audible energy sound. *J Intell Manuf* 20:43–54
25. Weingaertner WL, Schroeter RB, Polli ML, Gomes JDO (2006) Evaluation of high-speed end-milling dynamic stability through audio signal measurements. *J Mater Process Technol* 179:133–138
26. Nuawi MZ, Lamin F, Nor MJM, Jamaluddin N, Abdullah S, Nizwan CKE (2007) Integration of I-kaz coefficient and Taylor tool life curve for tool wear progression monitoring in machining process. *I J Mech* 4(1):44–50
27. Abbas J, Al-Habaibeh A, Su D (2011) Sensor fusion for condition monitoring system of end milling operations. *Key Eng Mater* 450: 267–270
28. Mannan MA, Kassim AA, Jing M (2000) Application of image and sound analysis techniques to monitor the condition of cutting tools. *Pattern Recogn Lett* 21(11):969–979
29. Grazeviciute J, Skiedraite I, Jurenas V, Bubulis A, Ostasevicius V (2008) Applications of high frequency vibrations for surface milling. *MECHANIKA* 1:46–49
30. Dauksevicus R, Kulvietis G, Ostasevicius V, Milasauskaite I (2010) Finite element analysis of piezoelectric microgenerator—towards optimal configuration. *Euroensors XXIV conference. Proc Eng* 5:1312–1315