

Sharof Shukhratov^{1,2} 
 Rimvydas Milašius¹
 Jakhongir Gafurov³ 
 Batir Mardonov⁴ 
 Kabuljon Gafurov⁴ 
 Md. Reazuddin Repon^{1,5,6,*} 

Investigation of Open End Yarn Tension Using an Elastic Yarn-Guide

DOI: 10.5604/01.3001.0014.8230

Abstract

This paper presents the results of Open End (OE) yarn tension investigation using a yarn-guide funnel with an elastic element. Obtained were the dependencies of tension change on such factors as body mass, elastic element rigidity, yarn coordinates on the funnel surface, and the speed of yarn moving. The values of these factors cause fluctuations in yarn tension and, consequently, in yarn structure and characteristics. On the basis of experiments, it was shown that due to using of a yarn-guide funnel with an elastic element, a decrease in yarn unevenness is achieved. It is easily regulated by the funnel mass, the rigidity rate of the elastic element, and the spinning speed.

Key words: OE, tension, elastic element, yarn-guide funnel, yarn unevenness, rigidity rate.

¹ Kaunas University of Technology,
 Faculty of Mechanical Engineering and Design,
 Department of Production Engineering,
 Studentu 56, LT-51424, Kaunas, Lithuania,
 * e-mail: reazmbstu.te@gmail.com

² Fergana State University,
 Department of Life Safety,
 Fergana, Uzbekistan

³ Jizzakh Polytechnic Institute,
 Department of Processing of Textile Materials,
 Jizzakh, Uzbekistan

⁴ Tashkent Institute of Textile and Light Industry,
 Department of Textile Industry Technology,
 Tashkent, Uzbekistan

⁵ ZR Research Institute for Advanced Materials,
 Sherpur-2100, Bangladesh

⁶ Khwaja Yunus Ali University,
 Department of Textile Engineering,
 Sirajgang-6751, Bangladesh

attention should be paid to the consumer-oriented quality of yarn produced. This situation has been the basis for the development of new comprehensive scientific and practical approaches of scientists and specialists in the textile industry.

Recently, as a result of a sharp OE spinning speed increase, the productivity of machines has also increased, but the quality of yarn produced has deteriorated, i.e. unevenness in its structure has increased [1-4]. A number of scientific papers are devoted to assessing OE yarn structure and characteristics [5-16], mainly describing the structural features of OE yarn. To study the structure microscopy and the cross-sectional methods were used, by means of which fibre migration was estimated. Also, yarn structure was evaluated from the results of determining its characteristics. In some papers [17-19], the structure of yarn is evaluated based on the investigation of technological processes. Investigations were also conducted to determine the influence of spinning chamber parameters on yarn structure and characteristics [20-21]. It should be noted that with the increasing speed of the spinning chamber, the unevenness of the yarn increases, which is an undesirable fact [2]. As a result, the quality of products made from such yarn and, accordingly, its competitiveness, decrease. In the above-

mentioned papers, there are no recommendations for improving the structure and characteristics of OE yarn produced at high speeds. Various designs were also studied, where the main disadvantages of these designs were the inability to eliminate dynamic shocks that affect the formation of the yarn [22-23]. In order to improve the structure and characteristics of OE yarn and to increase the competitiveness of textile products manufactured from it, there is a need to improve the design of working bodies that directly affect structural changes, i.e. yarn tension. To achieve this goal, the yarn-guide elastic funnel device is proposed [24] because, as a result of research, the advantage of its application was proved [25].

Materials and Methods

Materials

For experimental research and confirmation of theoretical assumptions, cotton fibre was chosen, properties of which, according to HVI, are given in **Table 1**.

In order to investigate the possibility of reducing twist unevenness with the use of an elastic (movable) funnel, it was necessary to use a shorter fibre. As a raw material for the production of yarn, cotton fibre regenerated from spinning waste was selected in two versions:

Introduction

Expansion of the yarn range and the intensive increase in demand for it have led to the improvement of technological equipment for its formation. There has appeared the necessity of the determination and study of all factors influencing yarn structure and characteristics as well as their analysis and finding of an appropriate solution. To meet demand requirements, along with technological quality,

Table 1. Properties of cotton fibre according to HVI.

Kod	Mic	Strength, g/tex	Rd, %	+b	T	UI	UHML, Inch-100	Elong, %	SFI, %
37	4.5	31.0	79.3	9.2	4	82.5	113.5	11.0	5.1

Table 2. Properties of regenerated cotton fibre according to HVI.

Mic	Strength, g/tex	Rd, %	+b	T	UI, %	UHML, mm	Elong, %
4.2	24.9	72.1	9.9	3	76.2	25.4	7.3

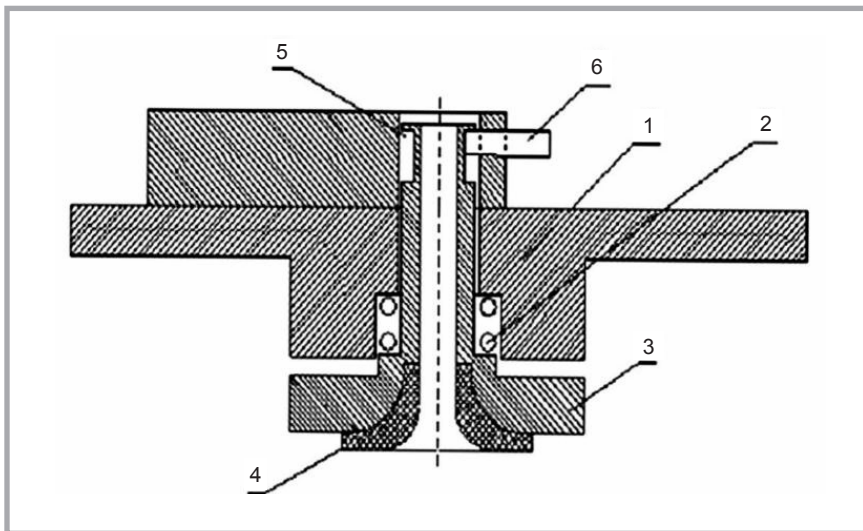

Figure 1. Yarn-outlet funnel with elastic element. 1 – Body separator, 2 – spring, 3 – funnel base, 4 – funnel, 5 – slot, 6 – clamp.

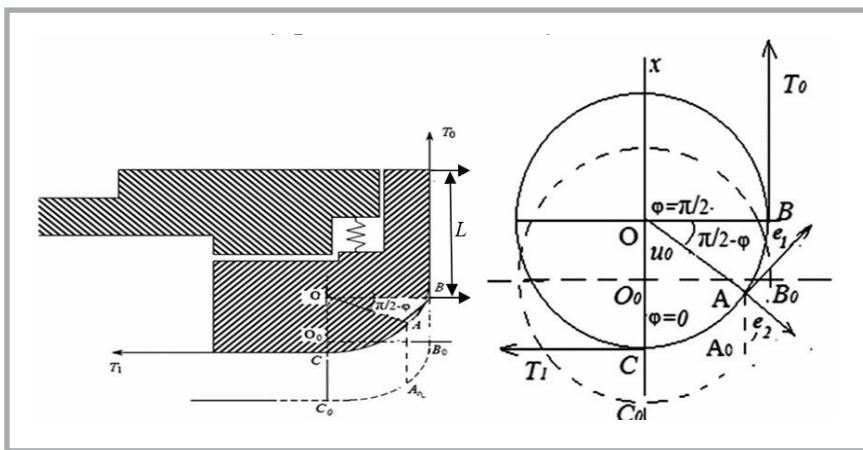

Figure 2. Analysis diagram of yarn-outlet funnel with elastic element operation.

100% cotton fibre, and a mixture of 85% regenerated fibre and 15% cotton fibre. HVI properties of the regenerated cotton fibre are shown in **Table 2**.

Methods

The experimental study was carried out in the production conditions of “Uz tex Tashkent”, where, without changing the parameters of the equipment, a tape of a linear density of 5 ktex was produced on a draw frame of the second transition, which was used as a feeding product for the OE machine. A movable elastic funnel was installed on a BD-330 spinning machine installed in the TITLI spinning laboratory, where yarn samples of all variants were produced. A test of yarn to determine its properties was carried out in the “Sentex Uz” laboratory at TITLI. The regeneration of spinning waste was carried out in a regenerator of the Chinese company SHANDONG SHUNXING MACHINERY CO. LTD at the joint

venture “Barakat Alpha”. The properties of cotton fibre and regenerated fibre were determined on an HVI 1000 instrument under production conditions.

As a result of experiments to determine the influence of the rotor rotation frequency on the properties of rotor yarn, it was found that with an increase in the rotor speed, the roughness of the yarn in terms of properties increases. This is the result of the increased variation in the tension of the yarn being formed. To reduce tension variations, it is proposed to use a yarn guide device operating on the damper principle, i.e. an elastic yarn guide is used. The yarn-conducting device of the rotor spinning machine contains a separator, a stopper installed on the basis of the separator, a funnel with a base possessing a yarn tube that is integral with it, and a spring located in a recess in the cage. On the surface of the base of the yarn extraction funnel in

contact with the separator, a depression is made to form a concentric protrusion in the centre.

Theoretical part

In papers [1-4], it is noted that with an increase in the rotational speed of the spinning chamber, the unevenness of yarn properties and tension in the cylinder increase, which leads to a change in tension of the fibre arrangement in the torsion triangle in the chamber groove. Under the influence of variable yarn tension, the arrangement of fibres at its open end changes, which is a source of structural unevenness. To reduce its value, it is necessary to reduce the amplitude of fluctuations for yarn tension in the cylinder. One of the ways to reduce it is using elastic elements in the zone of yarn formation. Proposed is an elastic yarn-outlet funnel (**Figure 1**) equipped with elastic element 2, due to which there is a possibility of free movement along its axis under the influence of yarn tension moving along its smooth surface [25-27].

The elastic yarn-guide works as follows. With an increase in the frequency of rotation of the spinning chamber, the variation in the tension of the yarn in the cylinder increases, which leads to a change in the tension of the arrangement of fibres in the torsion triangle. Under the influence of variable yarn tension, the arrangement of fibres at its open end changes, which is a source of deterioration in the quality of the yarn. To reduce the amount of variation, it is necessary to reduce the amplitude of fluctuations in the tension of the yarn in the balloon. With a change in the amplitude of fluctuations in the tension of the yarn in the balloon, the funnel on an elastic basis begins to perform a synchronously reciprocating motion. If the yarn tension increases, the funnel moves upward, the elastic element contracts, and the yarn tension decreases. If the yarn tension decreases, the funnel moves downward under the action of an elastic element. Thus, as a result of the variation in the amplitude of fluctuations in the tension of the yarn, a synchronous movement of the funnel occurs on an elastic basis, thereby reducing the variation in the amplitude of oscillations in the structure of the yarn being formed and improving its quality.

To determine the smoothing of fluctuations in the tension of the yarn formed in the spinning chamber, a diagram was drawn up (**Figure 2**), and the operation

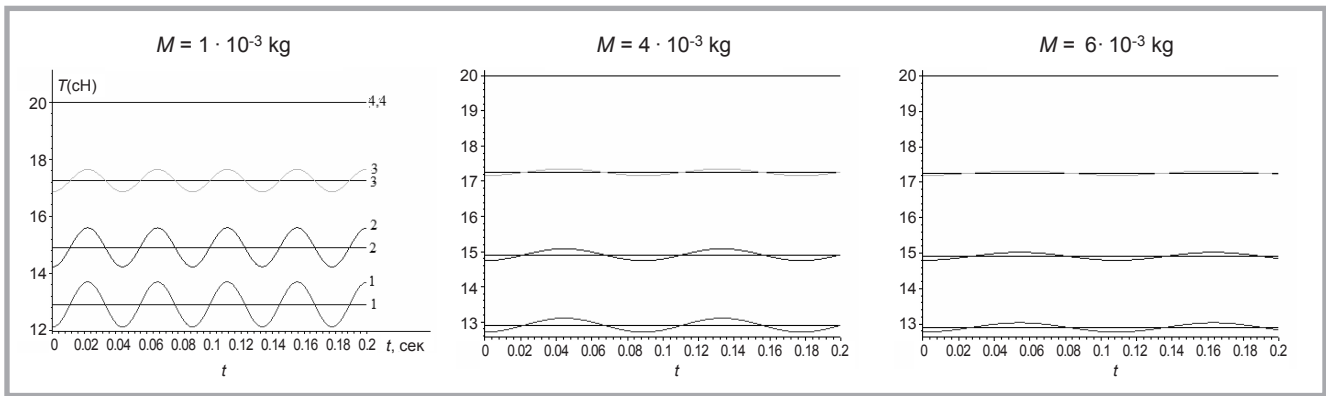

Figure 3. Tension change with time at different angles φ of the contact arc at relative yarn speed $v = 10$ m/min and different body mass values M , 1 – $\varphi = 0$, 2 – $\varphi = 30^\circ$, 3 – $\varphi = 60^\circ$, 4 – $\varphi = 90^\circ$.

of the elastic yarn-guide was analytically studied. The following assumptions were made: 1) It is assumed that the length of the yarn rectilinear zone repeatedly exceeds the length of the yarn contact arc with the surface of the funnel (body), i.e. $L \gg AB$. 2) The body oscillates only in the vertical direction. 3) The contact of yarn with the body occurs at point B , and in this regard the influence of yarn movement on site AB on the oscillatory process of the body is not taken into account.

Let the yarn points of the site in the form of an arc of circle BC move in relation to body 4 at a constant speed v . In this case, the solid body 4 together with the base 3 (Figure 1) with an elastic element (spring) perform a vertical motion according to law $u_0(t)$. In the presence of a moving body, each yarn point of site BAC , except the fractional one along arc $B\check{C}$, makes a translation in the vertical direction according to law $u_0(t)$. Entering angular coordinate $s = R\varphi$, we write the equation of yarn moving along the contact arc $0 < \varphi < \alpha/2$, proposed in paper [6]

$$\frac{1}{R} \frac{\partial(T - \mu v^2)}{\partial \varphi} \vec{e}_1 + \frac{1}{R} (T - \mu v^2) \vec{e}_2 + \vec{F} = \mu \vec{w}_e + \mu \vec{w}_c \quad (1)$$

Where, R – arc radius $C\check{B}$, m; T – tension, H; μ – yarn linear mass, kg/m (10^6 g/km); \vec{e}_1 and \vec{e}_2 – unit vectors directed respectively along the tangent normal to the contact arc $C\check{B}$; \vec{w}_e – vector of portable acceleration of yarn points, m/sec²; \vec{w}_c – Coriolis is the acceleration vector, m/sec², and \vec{F} – contact force between the yarn and body surface, H. In the case under consideration, there is no portable rotational motion of the body; therefore, $\vec{w}_c = 0$. We represent the translational acceleration vector \vec{w}_e at the vertical

movement of the body by means of unit vectors \vec{e}_1 and \vec{e}_2 , i.e.

$$\vec{w}_e = \ddot{u}_0 (\vec{e}_1 \sin \varphi - \vec{e}_2 \cos \varphi) \quad (2)$$

As a result of yarn contact with the body surface, tangential and normal forces arise, the intensities of which are denoted by τ and q , i.e.

$$\vec{F} = -\tau \vec{e}_1 - q \vec{e}_2 \quad (3)$$

Next, we accept the Coulomb-Amonton conditions on the contact line, i.e. $\tau = f\check{q}$ (where f – coefficient of friction between yarn and body surface).

Equation (1) takes into account the Equations (2) and (3) in the projections of the directions of vectors \vec{e}_1 and \vec{e}_2

$$\frac{1}{R} \frac{\partial(T - \mu v^2)}{\partial \varphi} - \tau = \mu \ddot{u}_0 \sin \varphi \quad (4)$$

$$\frac{T - \mu v^2}{R} - q = -\mu \ddot{u}_0 \cos \varphi \quad (5)$$

Taking into consideration the conditions $\tau = f\check{q}$, we formulate an equation for the determination of tension T

$$\frac{\partial(T - \mu v^2)}{\partial \varphi} - f(T - \mu v^2) = R\mu \ddot{u}_0 (\sin \varphi + f \cos \varphi)$$

Integrating this equation with condition $T = T_0$ at $\varphi = \pi/2$, we obtain

$$T = (T_0 - \mu v^2) e^{f(\varphi - \pi/2)} - e^{f\varphi} R\mu \ddot{u}_0 \int_{\varphi}^{\pi/2} (\sin t + f \cos t) e^{-ft} dt + \mu v^2$$

After calculating the integral, we finally obtain

$$T = (T_0 - \mu v^2) e^{f(\varphi - \pi/2)} + R\mu \ddot{u}_0 \cos \varphi + \mu v^2 \quad (6)$$

Putting $\ddot{u}_0 = 0$ into Equation (6), we can obtain an expression for tension during operation [6].

Now, we determine the composite force acting on the body using integral

$$Q = R \int_0^{\pi/2} \tau \sin \varphi d\varphi = Rf \int_0^{\pi/2} q \sin \varphi d\varphi$$

Using value q from Equation (5), we obtain

$$Q = f \int_0^{\pi/2} [(T_0 - \mu v^2) e^{f(\varphi - \pi/2)} + R^2 \mu \ddot{u}_0 \cos \varphi] \sin \varphi d\varphi = f \frac{(T_0 - \mu v^2)(e^{f\pi/2} - f)}{1 + f^2} - R\mu \ddot{u}_0 / 2$$

Now, we formulate an equation for the motion of the body

$$M_1 \ddot{u}_0 = -Mg + Q = -Mg + f \frac{(T_0 - \mu v^2)(e^{f\pi/2} - f)}{1 + f^2} - k_0 u_0$$

Where, $M_1 = M + M_n$, M – mass of the body, $M_n = R\mu/2$ – added mass, and k_0 – rigidity coefficient of the elastic element. The solution of the last equation satisfying zero initial conditions has the following form

$$u_0 = \frac{A_0}{\omega^2} (1 - \cos \omega t)$$

Where

$$A_0 = \frac{M}{M_1} \left[f \frac{(T_0 - \mu v^2)(e^{f\pi/2} - f)}{M(f^2 + 1)} - g \right], \quad \omega = \sqrt{\frac{k_0}{M_1}}$$

To implement the oscillatory process with positive acceleration at the initial moment of time, it is necessary to fulfill the conditions for tension T_0

$$T_0 > T_* = \mu v^2 + \frac{f^2 + 1}{f(e^{f\pi/2} - 1)} Mg$$

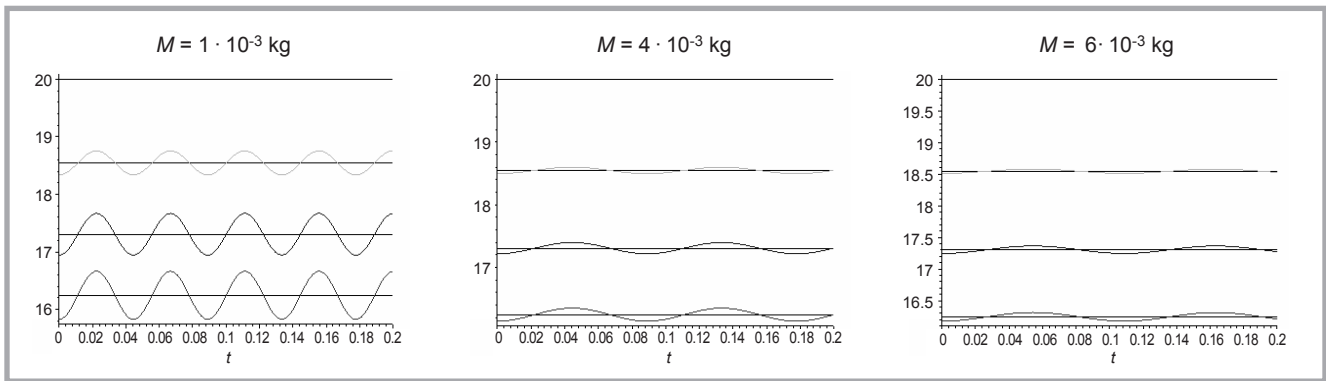

Figure 4. Tension change with time at different angles φ of the contact arc at relative yarn speed $v = 30$ m/min and different body mass values M , 1 – $\varphi = 0$, 2 – $\varphi = 30^\circ$, 3 – $\varphi = 60^\circ$, 4 – $\varphi = 90^\circ$.

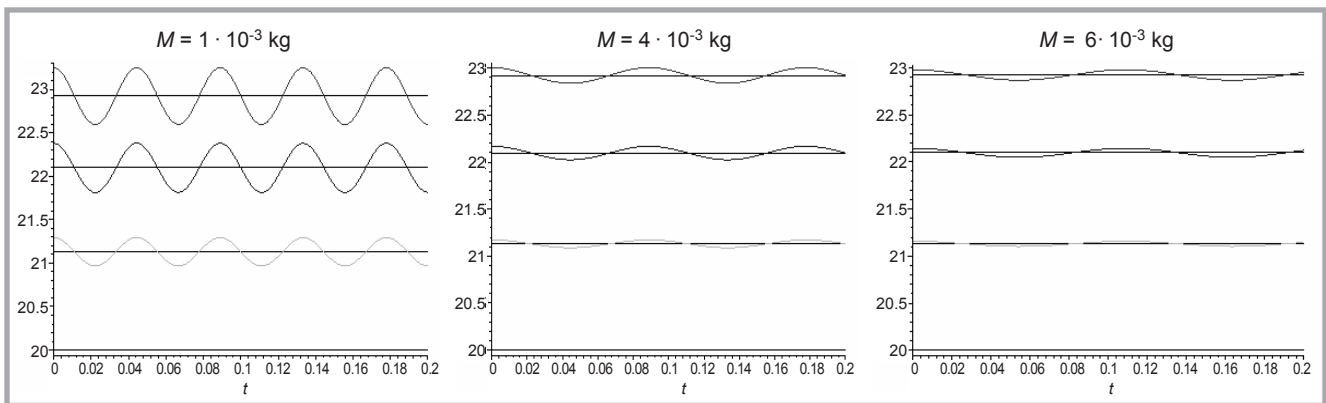

Figure 5. Tension change with time at different angles φ of the contact arc at relative yarn speed $v = 50$ m/min and different body mass values M , 1 – $\varphi = 0$, 2 – $\varphi = 30^\circ$, 3 – $\varphi = 60^\circ$, 4 – $\varphi = 90^\circ$.

At $T_0 < T^*$ the value of tension at the contact arc exit will not be enough to implement the oscillatory process. Yarn tension during the oscillatory process is described by equation

$$T = (T_0 - \mu v^2) e^{f(\varphi - \pi/2)} - R\mu A_0 \cos \omega t \cos \varphi + \mu v^2$$

Figures 3-4 present the curves of yarn tension change T (cH) with time t (sec) and angle φ (degree) for various values of

relative speed v (m/sec) and body mass M (kg). In the calculations it is accepted that $T_0 = 20$ cH, $\alpha = 90^\circ$, $\mu = 4 \cdot 10^{-5}$ kg/m, $f = 0.3$, $k_0 = 20$ N/m. Yarn tension during the elastic element's absence is shown by a black straight line. It is seen that the presence of the elastic element in the moving part of the body leads to the appearance of the oscillatory process, where the amplitudes of tension fluctuations have equal positive and negative devia-

tions from the tension magnitude during the elastic element's absence. and this effect manifests itself at low body masses and a high relative speed of the yarn along the contact arc. At relatively large values of the body mass ($M > 10^{-3}$ kg), the effect of tension fluctuations with time is almost absent.

Yarn tension fluctuation with time can change the yarn structure and thus has a positive impact on the reduction of yarn structural unevenness. At low yarn speeds the oscillation process begins to come into effect when yarn enters the contact arc (**Figures 3 and 4**), and at higher speeds the effect of fluctuations occurs when yarn comes out of the contact zone (**Figure 5**).

In the diagrams you can see that OE yarn tension at low speed varies from 13 to 17 cN regardless of the body (funnel) weight. The use of an elastic funnel leads to a change in the formed yarn tension, and what is more the change is of a periodic nature. The fluctuation amplitude of yarn tension mainly depends on the body mass and yarn coordinates on the funnel surface.

Table 3. OE yarn properties.

No.	Properties	Yarn			
		Ordinary		Experimental	
1	Linear density, tex	20	40	20	40
2	Breaking load, cN	237	492	237	516
3	Unevenness on breaking load, %	6.7	5.7	2.5	5.7
4	Ultimate elongation, %	5.13	5.92	6.0	6.25
5	Breaking strength, cN/tex	12.07	12.56	12.08	13.16

Table 4. Yarn twist rates.

No.	Rates	20 tex				50 tex			
		Ordinary		Experimental		Ordinary		Experimental	
1	Regenerated fibre in the mixture, %	85	100	85	100	85	100	85	100
2	Number of twists, tw/min	922	928	927	936	470	506	473	521
3	Unevenness along twist, %	4.4	5.3	3.2	5.2	3.9	3.4	5.9	4.7

At a low speed of yarn motion, maximum amplitudes are observed at the surface entrance, and at relatively high speeds high fluctuations take place at the funnel surface exit. It is to be noted that the oscillatory nature of the formed yarn tension changes and, regardless of its location coordinate on the funnel surface affects, the yarn structure, i.e. its twist, density and fibre migration. Under favourable conditions as affected by tension change in the twist being distributed in the yarn more evenly, the fibres in it are compacted and, consequently, their characteristics improve. On the other hand, if the rigidity of the elastic element is incorrect, the deterioration of properties may occur. Therefore, it is recommended to choose the rigidity of the elastic element taking into account the linear density of the yarn, the mass of the funnel and the spinning speed.

■ Results and discussion

To check the results of the theoretical research, an experiment was conducted with a OE spinning machine using an elastic funnel in three variants, i.e. feeding a ribbon of 100% cotton fibre, sorting 4-I, a ribbon of 100% regenerated direct waste fibre, and combined ribbon consisting of 85 % regenerated fibre and 15% fibre of sorting 4-I. Test results of yarn samples obtained with and without an elastic funnel are shown in **Tables 3 and 4**.

As is seen from **Table 1**, the breaking load of ordinary yarn samples with a linear density of 20 tex obtained using an elastic funnel has an equal value (237 cN), while the unevenness of the breaking load significantly decreased (from 6.7% till 2.5%), which clearly proves the effect of elastic funnel application. For yarn with a linear density of 40 tex, a different effect is observed, i.e. the unevenness of the breaking load has not changed, which is most likely due to the necessity of selecting an elastic element of different rigidity. The same is observed for twist indicators (**Table 2**). The unevenness of the twist of two linear densities of 20 tex decreases with elastic funnel use, while for yarn samples of 50 tex, the unevenness of the twist increases with the use of an elastic yarn-guide. This proves that an elastic funnel must be selected depending on the technological and kinematic parameters of the OE spinning machine.

■ Conclusions

As a result of OE yarn tension investigation using a yarn-guide funnel with an elastic element, obtained were the dependences of the change in tension on such factors as body mass, the coordinates of yarn on the funnel surface and the speed of the yarn. The values of these factors cause fluctuations in the tension and structure. Due to the use of a yarn-guide funnel with an elastic element, the reduction in the structural unevenness of the yarn decreased 1.2 times, which is easily controlled by the choice of funnel mass and rigidity coefficient of the elastic element, considering the technological and kinematic parameters of the spinning machine.

References

- Gofurov JK, Jumaniyazov KJ, Turakulov B, Gofurov K. Effect of Rewind Chamber Speed on Properties of Yarn. *Textile problems* 2007; 2: 32-36.
- Simpson J, Patureau MA. Effect of Rotor Speed on Open-End Spinning and Yarn Properties. *Textile Research Journal* 1979; 49(8): 468-73.
- Manohar JS, Rakshit AK, Balasubramanian N. Influence of Rotor Speed, Rotor Diameter, and Carding Conditions on Yarn Quality in Open-End Spinning. *Textile Research Journal* 1983; 53(8): 497-503.
- Gafurov J, Kyosev Y. FEM Frequency Analysis of Rotors for Open End Spinning. *Proceedings of Aachen-Dresden International Textile Conference* 2013 Nov (Vol. 28, p. 29).
- Lord PR. The Structure Of Open-End Spun Yarn. *Textile Research Journal* 1971; 41(9): 778-84.
- Basu A. Yarn Structure-Properties Relationship. *Indian Journal of Fibre and Textile Research* 2009; 34(3): 287-94.
- Hearle JW, Grosberg P, Backer S. Structural Mechanics of Fibers, Yarns, and Fabrics. 1969; p. 469.
- Van Langenhove L. Simulating the Mechanical Properties of a Yarn Based on the Properties and Arrangement of its Fibers Part II: Results of Simulations. *Textile Research Journal* 1997; 67(5): 342-7.
- Van Langenhove L. Simulating the Mechanical Properties of a Yarn Based on the Properties and Arrangement of its Fibers: Part III: Practical Measurements. *Textile Research Journal* 1997; 67(6): 406-12.
- Sherbakov VP. Calculation of Yarn Strength Using Theory of Anisotropic Body Elasticity. *Universities news* 1996; 6: 10-13.
- Al Mamun R, Repon MR, Islam MT, Motaleb KZ. Promising Effect of Processing Parameters on Yarn Properties in Rotor

- Spinning. *Manufacturing Science and Technology* 2017; 4(1): 11-5.
- Zhang H, Chen D, Wan Y. Fiber Migration and Twist Radial Distribution in Rotor Spun Yarns. *Textile Research Journal* 2003; 73(11): 945-8.
- Jiang XY, Hu JL, Cheng KP, Postle R. Determining the Cross-Sectional Packing Density of Rotor Spun Yarns. *Textile Research Journal* 2005; 75(3): 233-9.
- Pillay KP, Viswanathan N, Parthasarathy MS. The Structure and Properties of Open-End Yarns: Part I: A Study of Fiber Configurations and Migration. *Textile Research Journal* 1975; 45(5): 366-72.
- Soe AK, Takahashi M, Nakajima M, Matsuo T, Matsumoto T. Structure and Properties of MVS Yarns in Comparison with Ring Yarns and Open-End Rotor Spun Yarns. *Textile Research Journal* 2004; 74(9): 819-26.
- Gafurov JK, Mardonov BM, Peerzada MH, Gafurov K. Investigating the Strain State of Fibres Located on the Helical Line in Extended Yarn. *FIBRES & TEXTILES in Eastern Europe* 2015; 23, 2(110): 19-24.
- Gafurov JK, Sobirov A, Bobojanov KhT, Gafurov K. Assessment of Yarn Structure Basing on its Deformation. *Textile problems* 2013; 4. 46-51.
- Jumaniyazov K, Gafurov JK, Peerzada MH. Theoretical Modeling of Tight Structure of Open-end Yarn. *Science International* 2012; 24(1): 37-40.
- Gafurov J, Jumaniyazov K, Alishev Sh. The Analysis of Fibers Transportation on the OE Rotor's Inner Surface. *The Problems of Textiles Journal* 2007; 33-37.
- Manohar JS, Rakshit AK, Balasubramanian N. Influence of Rotor Speed, Rotor Diameter, and Carding Conditions on Yarn Quality in Open-End Spinning. *Textile Research Journal* 1983; 53(8): 497-503.
- Simpson J, Patureau MA. Effect of Rotor Speed on Open-End Spinning and Yarn Properties. *Textile Research Journal* 1979; 49(8): 468-73.
- Patent SU 1306179 A1.
- Patent SU 1309627 A1.
- Madrakhimov O Kh, Gafurov K, Mardonov B, Gafurov JK. Yarn-Guide Device Ofpneumatic Spinning Machine. *FAP 01059*, 2016;1: 87-88, Tashkent.
- Madrakhimov O Kh, Gafurov J K, Bobojanov Kh T. Using Of Elastic Funnelfor Pneumatic Spinning Machines. *Textile problems* 2014; 2: 56-59.
- Idzik M. Analysis of Changes in Fiber Density Distribution in a Cotton Combed Spinning System Using Modified Regulation of the Sliver Draft. *Autex Research Journal* 2019;19(1): 54-9.
- Lu Y, Wang Y, Gao W. Wicking Behaviors of Ring and Compact-Siro Ring Spun Yarns with Different Twists. *Autex Research Journal* 2019; 19(1): 68-73.

□ Received 23.11.2020 Reviewed 11.01.2021